



**Economic and Social
Council**

Distr.
GENERAL

TRANS/WP.29/2002/9
18 December 2001

Original: ENGLISH

ECONOMIC COMMISSION FOR EUROPE

INLAND TRANSPORT COMMITTEE

World Forum for Harmonization of Vehicle Regulations (WP.29)
(One-hundred-and-twenty-sixth session,
12-15 March 2002, agenda item 4.2.6.)

PROPOSAL FOR DRAFT SUPPLEMENT 22 TO THE 03 SERIES OF AMENDMENTS
TO REGULATION No. 37

(Filament lamps)

Transmitted by the Working Party on Lighting and Light-Signalling (GRE)

Note: The text reproduced below was adopted by GRE at its seventh session, and is transmitted for consideration to WP.29 and to AC.1. It is based on documents TRANS/WP.29/GRE/2000/10/Rev.1, as amended, TRANS/WP.29/GRE/2000/10/Rev.1/Add.1, not amended, and TRANS/WP.29/GRE/2001/32, also not amended (TRANS/WP.29/GRE/47, paras. []).

This document is a working document circulated for discussion and comments. The use of this document for other purposes is the entire responsibility of the user. Documents are also available via the INTERNET: <http://www.unece.org/trans/main/welcwp29.htm>

List of contents, annexes,

Annex 1, add at the end of the list new sheets, to read:

"...

Sheets H14"

Annex 5, the title, amend to read:

"Annex 5 - Checking the colour of filament lamps"

Paragraph 2.1.2.3., amend to read:

"... the other characteristics of a filament lamp emitting white light, does not constitute a change of type of the filament lamp;"

Paragraph 2.4.2., amend to read:

"... If the applicant so desires, the same approval code may be assigned to the filament lamp emitting white light and to the filament lamp emitting selective-yellow light (see para. 2.1.2.3.)."

Paragraph 3.1.5., amend to read:

"3.1.5. Standard (étalon) filament lamp: a filament lamp emitting white or amber light with reduced dimensional tolerances, used for the photometric testing of lighting and light-signalling devices. Standard filament lamps are specified in only one voltage rating for each category;"

Paragraph 3.4.2., amend to read:

"3.4.2. In the case of a filament lamp having a coated bulb, after the ageing period corresponding to paragraph 3.4.1. ..."

Paragraph 3.4.6., amend to read:

"... shall be at least 85 per cent of the specified luminous flux of the relevant filament lamp emitting white light."

Paragraphs 3.6. to 3.6.3., amend to read (including footnote 5/):

"3.6. Colour

3.6.1. The colour of the light emitted by the filament lamp shall be white unless otherwise specified on the relevant data sheet.

3.6.2. The colourimetric characteristics of the light emitted, expressed in CIE trichromatic coordinates, shall lie within the following limits:

finished filament lamps emitting white light:

limit towards blue: $x \geq 0.310$
limit towards yellow: $x \leq 0.500$
limit towards green: $y \leq 0.150 + 0.640 x$
limit towards green: $y \leq 0.440$
limit towards purple: $y \geq 0.050 + 0.750 x$
limit towards red: $y \geq 0.382;$

finished filament lamps emitting selective-yellow light:

limit towards red: $y \geq 0.138 + 0.580 x$
limit towards green: $y \leq 1.290 x - 0.100$
limit towards white: $y \geq 0.966 - x$
($y \geq 0.940 - x$ and $y = 0.440$ for front fog lamps)
limit towards spectral value: $y \leq 0.992 - x;$

finished filament lamps emitting amber light:

limit towards green: $y \leq x - 0.120$
limit towards red: $y \geq 0.390$
limit towards white: $y \leq 0.790 - 0.670 x.$

3.6.3. The colour of the light emitted shall be measured by the method specified in annex 5. Each measured value shall lie within the required tolerance area. ^{5/} Moreover, in the case of filament lamps emitting white light, the measured values shall not deviate more than 0.020 units in the x and/or y direction from a point of choice on the Planckian locus (CIE Publication 15.2 Colorimetry, 1986).

^{5/} For Conformity of Production purposes and for amber colour only, at least 80 per cent of the measuring results shall lie within the required tolerance area."

Paragraph 3.8., amend to read:

"..... above, for a filament lamp emitting white light as well as selective-yellow light; article 3 of the Agreement to which this Regulation is annexed

Paragraph 3.9.4., amend to read:

"3.9.4. Filament lamps emitting selective-yellow light shall be tested ... remain unchanged. This test shall be left out if the approval is also given to the same type of filament lamp emitting white light.

Paragraph 3.10., amend to read:

"3.10. Standard filament lamps

Additional requirements for standard (étalon) filament lamps are given on the relevant data sheets of annex 1.

Bulbs of standard (étalon) filament lamps emitting white light shall not alter the CIE trichromatic coordinates of a luminous source having a colour temperature of 2856 K by more than 0.010 units in the x and/or y direction.

For standard (étalon) filament lamps emitting amber light, changes of the bulb temperature shall not affect the luminous flux which might impair photometric measurements of signalling devices. Moreover, the colour shall be in the lower part of the tolerance area."

Annex 1,

Add at the end new data sheets H14/1 to H14/4, to read:

The drawings are intended only to illustrate the essential dimensions (in mm) of the filament lamp

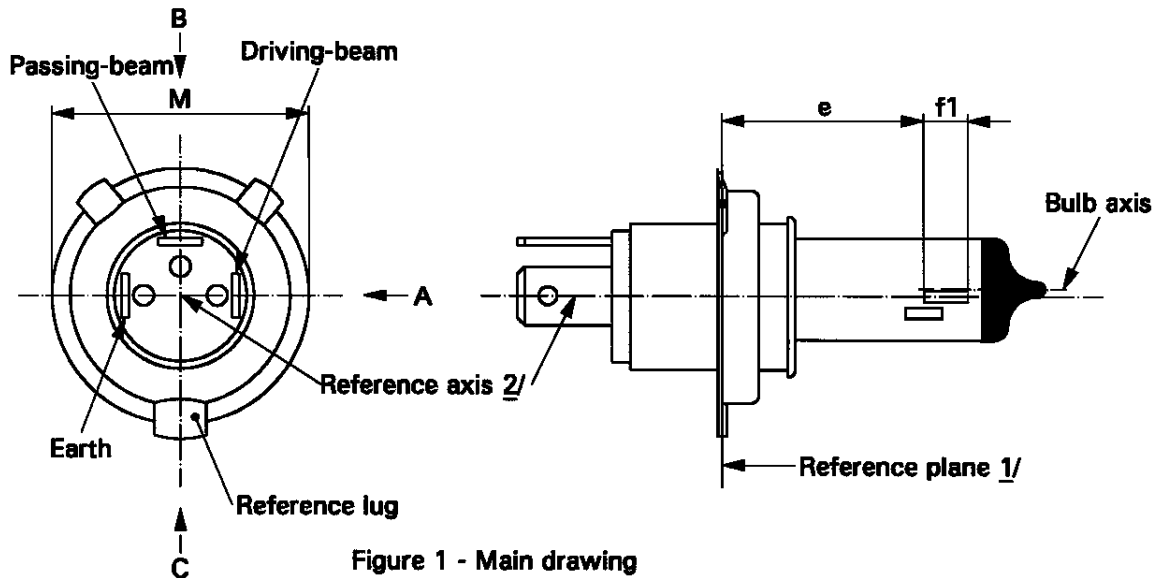

Figure 1 - Main drawing

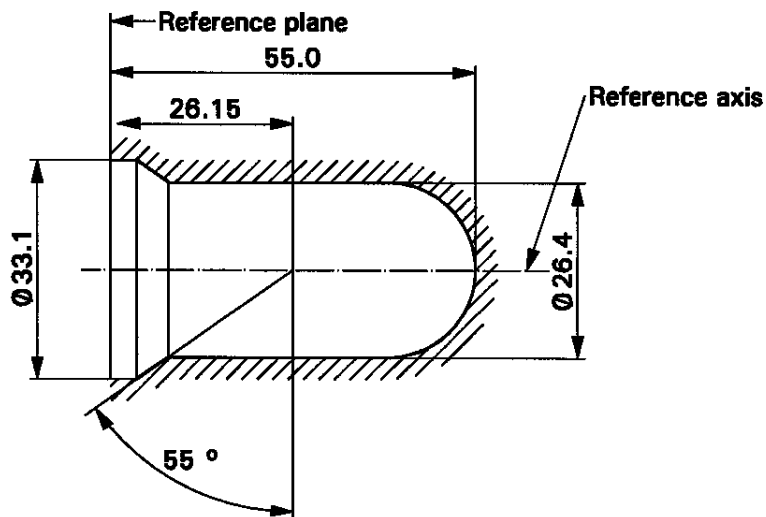
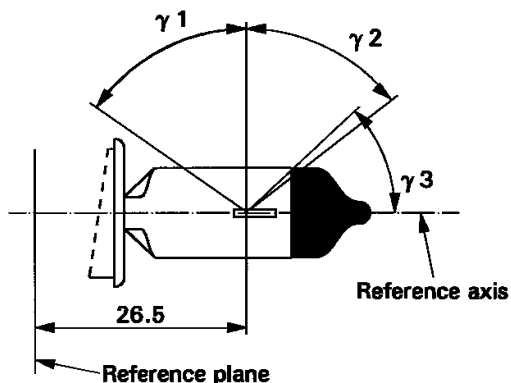
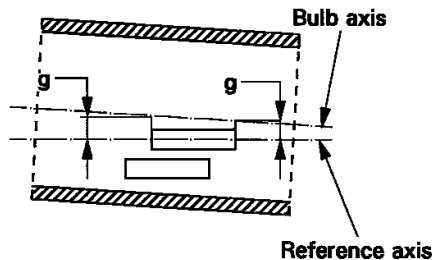

Figure 2 - Maximum lamp outline 3/

- 1/ The reference plane is defined by the points on the surface of the holder on which the three lugs of the cap ring will rest.
- 2/ The reference axis is perpendicular to the reference plane and passing through the center of the cap ring diameter 'M'.
- 3/ Glass bulb and supports shall not exceed the envelope as indicated in figure 2. The envelope is concentric to the reference axis.



View B Figure 3 - Distortion free area 4/ and black top 5/



View A Figure 4 - Bulb eccentricity 6/

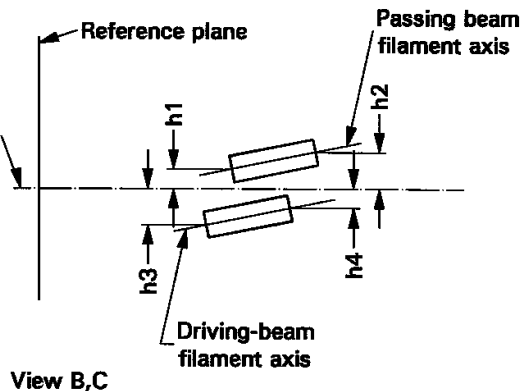
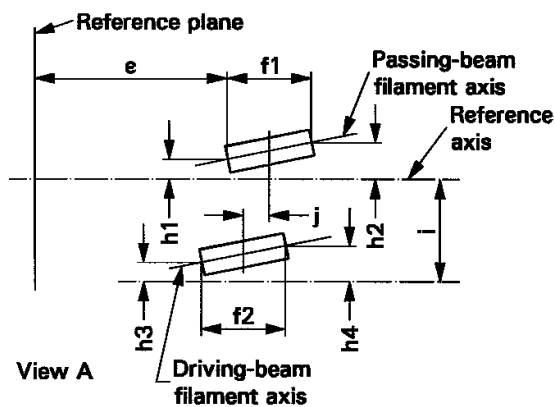

View A View B,C Figure 5- Offset of filament axis 7/ (for standard filament lamps only)

- 4/ Glass bulb shall be optically distortion free within the angles γ_1 and γ_2 . This requirement applies to the whole bulb circumference within the angles γ_1 and γ_2 .
- 5/ The obscuration shall extend at least to angle γ_3 and shall extend at least to the cylindrical part of the bulb on the whole bulb top circumference.
- 6/ Eccentricity of bulb with respect to passing-beam filament axis is measured in two planes parallel to the reference plane where the projection of the outside of the end turns nearest to or furthest from the reference plane crosses the passing-beam filament axis.
- 7/ The offset of the filaments with respect to the reference axis is measured only in viewing direction A, B and C as shown in figure 1 on sheet H14/1. The points to be measured are those where the projection of the outside of the end turns nearest to or furthest from the reference plane crosses the filaments axis.

CATEGORY H14

Sheet H14/3

Dimensions in mm		Filament lamp of normal production		Standard filament lamps	
e	<u>8/</u>	26.15	<u>12/</u>	± 0.1	
f1	<u>8/ 9/</u>	5.3	<u>12/</u>	± 0.1	
f2	<u>8/ 9/</u>	5.0	<u>12/</u>	± 0.1	
g		0.3 min.			
h1		0	<u>12/</u>	± 0.1	
h2		0	<u>12/</u>	± 0.15	
h3		0	<u>12/</u>	± 0.15	
h4		0	<u>12/</u>	± 0.15	
i		2.7		-	
j		2.5	<u>12/</u>	± 0.1	
γ1		55° min.	-	-	
γ2		52° min.	-	-	
γ3		43°	0/-5°	0/5°	
Cap P38t-33 in accordance with IEC Publication 60061 (sheet 7004-....-1)					
ELECTRICAL AND PHOTOMETRIC CHARACTERISTICS					
Rated values	Volts	12		12	
	Watts	55	60	55	60
Test voltage	Volts	13.2		13.2	
Objective values	Watts	68 max.	75 max.	68 max.	75 max.
	Luminous flux	1150 ± 15%	1750 ± 15%		
Reference luminous flux at approximately. 12 V				860	1300

8/ The ends of the filaments are defined as the points where, when the viewing direction is direction A as shown in figure 1 on sheet H14/1, the projection of the outside of the end turns crosses the filaments axis.

9/ "f1" represents the length of the passing-beam filament and "f2" represents the length of the driving-beam filament.

10/ "d1" represents the diameter of the passing-beam filament and "d2" represents the diameter of the driving-beam filament.

11/ Notes concerning the filaments diameter.

- No actual diameter restrictions apply but the objective for future developments is to have d1 max. = 1.6 mm and d2 max. = 1.6 mm.
- For the same manufacture, the design diameter of standard filament lamps and filament lamps of normal production shall be the same.

12/ To be checked by means of a "Box system"; sheet H14/4.

Screen projection requirements

This test is used to determine, by checking whether the filaments are correctly positioned relative to the reference axis and the reference plane, whether a filament lamp complies with the requirements.

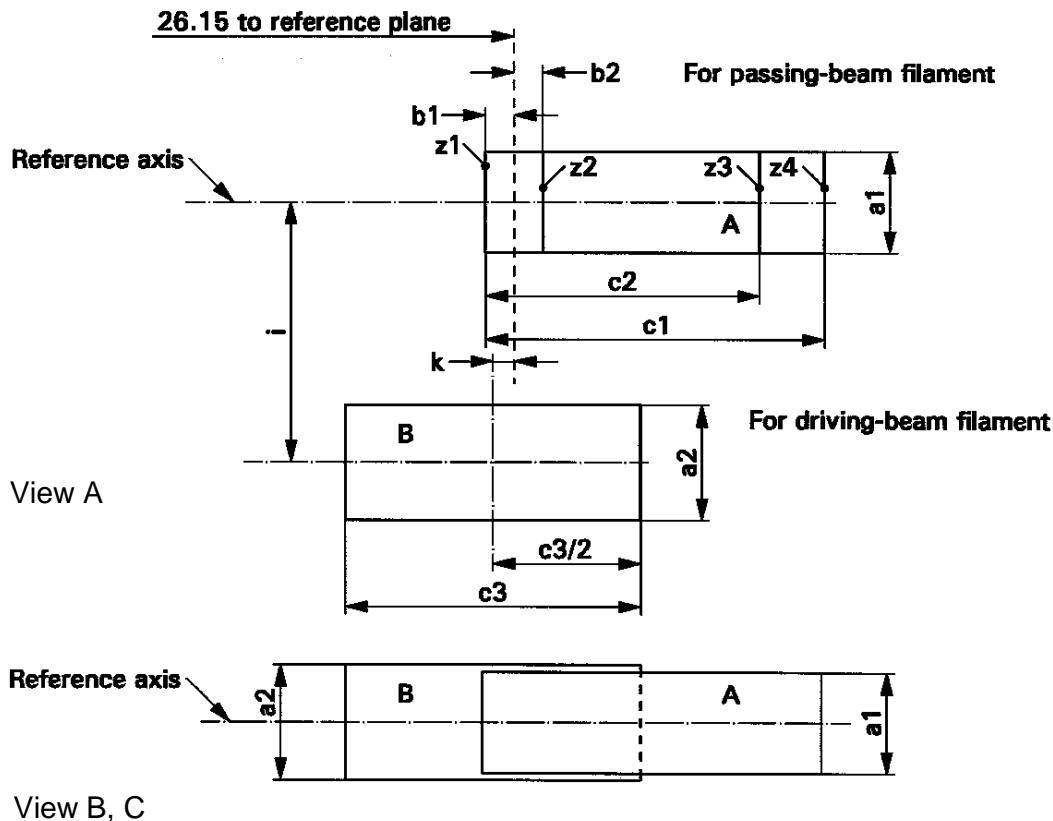

a1	a2	b1	b2	c1	c2	c3	i	k
d1 +0.5	1.6 * d2	0.2		5.8	5.1	5.75	2.7	0.15

d1 is diameter of the passing beam filament and d2 that of the driving beam filament

The positions of the filaments are checked solely in directions A, B and C as shown in figure 1 on sheet H14/1.

The passing-beam filament shall lie entirely in the rectangle A and the driving beam filament entirely in rectangle B

The ends of the passing-beam filament as defined on sheet H14/3, note 8/ shall lie between lines Z1 and Z2 and between lines Z3 and Z4.

Annex 5, amend to read:

"Annex 5

CHECKING THE COLOUR OF FILAMENT LAMPS

1. General
 - 1.1. Measurements shall be made on finished lamps. Filament lamps with secondary (outer) bulb acting as colour filter shall be handled as filament lamp with primary bulb.
 - 1.2. Tests shall be made at an ambient temperature of $23\text{ }^{\circ}\text{C} \pm 5\text{ }^{\circ}\text{C}$.
 - 1.3. Tests shall be made at test voltage as specified in the relevant lamp data sheet.
 - 1.4. Filament lamps shall be measured preferably in the normal operating position.
 - 1.5. Before starting a test, the stabilisation of the temperature of the filament lamp shall be obtained by operating at test voltage for 10 minutes.
2. Colour
 - 2.1. Colour tests shall be made with a measuring system that determines CIE trichromatic co-ordinates of the received light with an accuracy of ± 0.002 .
 - 2.2. The trichromatic coordinates shall be measured with a colourimetric receiver integrating over a right circular cone subtending an angle of minimum 5° and maximum 15° , at the centre of the filament.
 - 2.3. Measuring directions
(See the figure below).
 - 2.3.1. Initially, the receiver shall be positioned perpendicular to the lamp axis and to the filament axis (or plane in case of a curved filament). After measurement the receiver shall be moved around the filament lamp in bi-directional steps of about 30° until the area specified in paragraphs 2.3.2. or 2.3.3. is covered. In each position a measurement shall be made. However, no measurement shall be made when the centreline of the receiver coincides with the filament axis.
 - 2.3.2. For filament lamps used in headlamps, measurements shall be made in directions around the filament lamp with the centreline of the receiver aperture located within an angle $\pm 30^{\circ}$, from the plane perpendicular to the lamp axis with the origin in the centre of the filament. In case of filament lamps with two filaments, the centre of the driving-beam filament shall be taken.
 - 2.3.3. For filament lamps used in light signalling devices, measurements shall be made randomly around the filament lamp with exception of the area claimed or covered by the cap of the filament lamp, including the immediate transition area. In case of filament lamps with two filaments, the centre of the major filament shall be taken.

ANNEX 5

FIGURE ILLUSTRATING THE POSITIONS OF COLOURIMETRIC RECEIVER

