

Distr.  
GENERAL

TRANS/WP.29/GRSP/2001/16/Rev.2  
8 November 2002

ENGLISH ONLY

ECONOMIC COMMISSION FOR EUROPE

INLAND TRANSPORT COMMITTEE

World Forum for Harmonization of Vehicle Regulations (WP.29)

Working Party on Passive Safety (GRSP)  
(Thirty-second session, 10-13 December 2002,  
agenda item B.2.)

PROPOSAL FOR DRAFT SUPPLEMENT TO REGULATION No. 44  
(Child restraints)

Revision 2

Transmitted by the Expert from France

Note: The text reproduced below was prepared by the expert from France in order to introduce into Regulation No. 44 the new anchorage system standard for child restraint systems (CRS) groups 0, 0+, 1 prepared by the International Organization for Standardization (ISO). It is based on document TRANS/WP29/GRSP/2001/16/Rev.1.

The text is presented as follows:

"ISOFIX" is used as a qualified adjective in order to simplify the modification redaction and to allow child restraint system users to be able to identify ISOFIX restraints without any doubt,

---

Note: This document is distributed to the Experts on Passive Safety only.

Paragraph 2.1., amend to read:

"..., by limiting the mobility of the wearer's body;  
"ISOFIX" is a system for the connection of child restraint systems to vehicles which has two vehicle rigid anchorages, two corresponding rigid attachments on the child restraint system and a mean to limit the pitch rotation of the child restraint system."

Insert a new paragraph 2.1.1.6., to read:

"2.1.1.6 ISOFIX Child restraint systems fall into 5 ISOFIX size classes described in Regulation No. 16 annex 17, appendix 2:

- A - ISO/F3: Full Height Forward Facing toddler CRS
- B - ISO/F2: Reduced Height Forward Facing toddler CRS
- C - ISO/R3: Full Size Rearward Facing toddler CRS
- D - ISO/R2: Reduced Size Rearward Facing toddler CRS
- E - ISO/R1: Rearward Facing infant CRS
- F - ISO/L1: Left Lateral Facing position CRS (carry-cot)
- G - ISO/L2: Right Lateral Facing position CRS (carry-cot)

Mass group		ISOFIX size category
0 - up to 10 kg	F	ISO/L1
	G	ISO/L2
	E	ISO/R1
0+ - up to 13 kg	C	ISO/R3
	D	ISO/R2
	E	ISO/R1
I - 9 to 18 kg	A	ISO/F3
	B	ISO/F2
	C	ISO/R3
	D	ISO/R2

Paragraph 2.1.2.1., amend to read:

"2.1.2.1. A "universal" category for use as specified in paragraphs 6.1.1., 6.1.3.1. and 6.1.3.2. on most vehicle seat positions, and in particular those which have been assessed according to Regulation No. 16 - as being compatible with such a category of child restraint."

Insert new paragraphs 2.14.2. to 2.14.5., to read:

"2.14.2. **"ISOFIX low anchorage"** means one 6 mm diameter rigid round horizontal bar, extending from vehicle or seat structure to accept and restrain an ISOFIX child restraint system with ISOFIX attachments.

2.14.3. **"ISOFIX anchorages system"** means a system made up of two ISOFIX low anchorages fulfilling the requirements of Regulation No. 14 which is designed for attaching an ISOFIX child restraint system in conjunction with an anti-rotation device.

2.14.4. **"Anti-rotation device"**

- An anti-rotation device for an ISOFIX universal child restraint system consists of the ISOFIX top-tether.

- An anti-rotation device for an ISOFIX semi-universal child restraint system consists of either a top tether, the vehicle dashboard or a support leg intended to limit the rotation of the restraint during a frontal impact.
- For ISOFIX, universal and semi-universal, child restraint systems the vehicle seat itself does not constitute an anti-rotation device.

2.14.5. "ISOFIX top tether anchorage" means a feature fulfilling the requirements of Regulation No. 14, such as a bar, located in a defined zone, designed to accept an ISOFIX top tether strap connector and transfer its restraint force to the vehicle structure."

Insert a new paragraph 2.20.5., to read:

"2.20.5. "ISOFIX position" means a system which allows to install:

- either an universal ISOFIX forward facing child restraint system as defined in this Regulation
- or a semi-universal ISOFIX forward facing child restraint system as defined in this Regulation,
- or a semi-universal ISOFIX rearward facing child restraint system as defined in this Regulation
- or a semi-universal ISOFIX lateral facing position child restraint system as defined in this Regulation,
- or a specific vehicle ISOFIX child restraint system as defined in this Regulation."

Insert new paragraphs 2.28. to 2.36., to read:

"2.28. "ISOFIX attachment" means one of the two connections, fulfilling the requirement of paragraph 6.3.2. of this Regulation, extending from the ISOFIX child restraint system structure, and compatible with an ISOFIX low anchorage.

2.29. "ISOFIX child restraint system" means a child restraint system which has to be attached to an ISOFIX anchorage system fulfilling the requirement of Regulation No. 14.

2.30. "Seat bight" means the area close to the intersection of the surfaces of the vehicle seat cushion and the seat back.

2.31. "Vehicle seat fixture (VSF)" means a fixture, according to ISOFIX size classes defined in paragraph 2.1.1.7. and whose dimension are given in figures 1 to 6 of annex 17 appendix 2 of Regulation No. 16, used by a child restraint manufacturer to determine the appropriate dimensions of an ISOFIX child restraint system and the location of its ISOFIX attachments.

2.32. "ISOFIX top tether connector" means a device intended to be attached to an ISOFIX top tether anchorage.

2.33. "ISOFIX top tether hook" means an ISOFIX top tether connector typically used to attach an ISOFIX top tether strap to an ISOFIX top tether anchorage as defined in figure 3 of Regulation No. 14.

2.34. "ISOFIX top tether strap" means a webbing strap (or equivalent) which extends from the top of an ISOFIX child restraint system to the ISOFIX top tether anchorage, and which is equipped with an adjustment device, a tension-relieving device, and a top tether connector.

- 2.35. "ISOFIX top tether attachment" is a device to secure the ISOFIX top tether strap to the ISOFIX child restraint system.
- 2.36. "a tension relieving device" means a system which allow to release the device which adjust and maintain the tension in the top tether strap."

Insert a new paragraph 4.9., to read:

"4.9. ISOFIX Marking

PROPOSAL A (CONSUMER INTERNATIONAL)

[If the product includes ISOFIX attachments, the following information must be permanently visible to someone installing the restraint in a vehicle:

- ISOFIX - followed by the letter(s) that is/are appropriate for the ISOFIX size class (es) into which the product fits. The letter(s) shall be colour coded as follows:
  - Rearward facing applications BLUE
  - Forward facing applications RED
  - Lateral facing applications BLACK
- The following information can be conveyed by pictograms and/or text. The marking must indicate:
  - The essential relevant steps for making the seat ready for installation. For example, the method of extending the ISOFIX latch system must be explained.
  - The position, function, and interpretation of any tell tales must be explained.
  - The position and use of top tethers, or other means of limiting seat rotation requiring action by the user, must be explained.
  - The adjustment of ISOFIX latches and the top tether, or other means of limiting seat rotation, requiring action of the user must be explained.
- The marking must be permanently attached and be visible to a user installing the seat on either side of the vehicle."]

Paragraph 6.1.3., amend to read:

"6.1.3. According to the category which it belongs to, the child restraint shall be secured to the vehicle structure or to the seat structure;

POSSIBLE CONFIGURATIONS FOR APPROVAL

GROUPS / CATEGORIES TABLE

Group	Category	Universal(1)		Semi-universal(2)		Restricted		Specific Vehicle	
		CRS	ISOFIX CRS	CRS	ISOFIX CRS	CRS	ISOFIX CRS	CRS	ISOFIX CRS
0	Carry-cot	A	NA	A	A	A	NA	A	A
	Rearward facing	A	NA	A	A	A	NA	A	A
0+	Rearward facing	A	NA	A	A	A	NA	A	A
I	Rearward facing	A	NA	A	A	A	NA	A	A
	Forward facing (integral)	A	A	A	A	A	NA	A	A
	Forward facing (non integral)	A	NA	A	A	A	NA	A	A
II	Forward facing (integral)	A	NA	A	NA	A	NA	A	A
	Forward facing (non integral)	A	NA	A	NA	A	NA	A	A
III	Forward facing (integral)	A	NA	A	NA	A	NA	A	A
	Forward facing (non integral)	A	NA	A	NA	A	NA	A	A

With:

CRS: Child restraint system

A: Applicable

NA: Non Applicable

(1) ISOFIX universal CRS means forward facing restraints for use in vehicles with positions equipped with ISOFIX anchorages system and a top tether anchorage.

(2) ISOFIX semi universal CRS means:

- forward facing restraints equipped with support leg or
- rearward facing restraints equipped with a support leg or a top tether strap for use in vehicles with positions equipped with ISOFIX anchorages system and a top tether anchorage if needed
- or rearward facing restraints, supported by the vehicle dashboard, for use in the front passenger seat equipped with ISOFIX anchorages system, or
- lateral facing position restraint equipped if needed with an anti-rotation device for use in vehicles with positions equipped with ISOFIX anchorages system and top tether anchorage if needed."

Paragraph 6.1.3.1., amend to read:

**"6.1.3.1.** For the "universal" and "restricted" categories, by means of an adult safety-belt (with or without a retractor) meeting the requirements of Regulation No. 16 (or equivalent) fitted to anchorages meeting the requirements of Regulation No. 14 (or equivalent)."

Insert a new paragraph 6.1.3.2., to read:

**"6.1.3.2.** For ISOFIX "universal" child restraint systems by means of ISOFIX attachments and ISOFIX top tether strap meeting the requirements of this Regulation fitted to ISOFIX anchorages and ISOFIX top tether anchorage meeting the requirements of Regulation No. 14."

Paragraph 6.1.3.2. (former), renumber as paragraph 6.1.3.3.

Insert a new paragraph 6.1.3.4., to read:

**"6.1.3.4.** For ISOFIX "semi-universal" Child Restraint Systems by means of ISOFIX attachments and ISOFIX top tether strap or a support leg or vehicle dashboard, meeting the requirements of this Regulation fitted to ISOFIX anchorages and/or ISOFIX top tether anchorage meeting the requirements of Regulation No. 14."

Paragraphs 6.1.3.3. and 6.1.3.4. (former), renumber as paragraphs 6.1.3.5. and 6.1.3.6.

Paragraph 6.1.6., the reference to document "TRANS/WP.29/78/Rev.1, paragraph 1.42.", should read "TRANS/WP.29/78/Rev.1, paragraph 1.20."

Paragraphs 6.1.8. and 6.1.9., amend to read:

**"6.1.8.** In the case of a child restraint system of the "universal" category, **except ISOFIX universal child restraint systems**, the main load-bearing contact point, between the child restraint and the adult safety-belt shall not be less than 150 mm from the Cr axis when measured with the child restraint on the dynamic test bench ...

**6.1.9.** If the adult belt is required to secure a "universal" category child restraint, its maximum length to be used on the dynamic test bench is defined in annex 13 to this Regulation.

To check compliance with this requirement, ..."

Insert new paragraphs 6.3. to 6.3.4., to read:

**"6.3.** ISOFIX restraint specifications

**6.3.1.** General characteristics

**6.3.1.1.** Dimensions

The maximum lateral, downward, and rearward dimensions for the ISOFIX child restraint system and the locations of the ISOFIX anchorages with which its attachments must engage are defined for the ISOFIX child restraint system manufacturer by the Vehicle Seat Fixture (VSF) defined by paragraph 2.31. of this Regulation.

**6.3.1.2.** Mass

The mass of an ISOFIX child restraint system of universal and semi-universal categories and of mass group 0, 0+,1 shall not exceed 15 kg.

6.3.2. ISOFIX Attachments

6.3.2.1. Type

ISOFIX Attachments may be according to examples shown in Figure 0c, or other appropriate designs that are part of a rigid mechanism having provision for adjustment, the nature of which is determined by the ISOFIX child restraint system manufacturer.

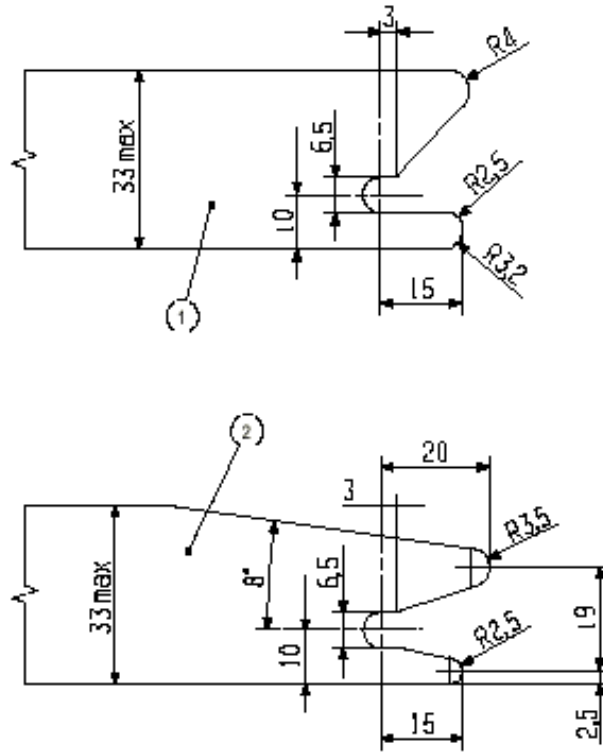

Dimensions in mm

Figure 0c

Key

- 1 ISOFIX child restraint system attachment - example 1
- 2 ISOFIX child restraint system attachment - example 2

6.3.2.2. Dimensions

Dimensions for the portion of the ISOFIX child restraint system attachment that engages the ISOFIX anchorage system must not exceed the maximum dimensions given by the envelope in Figure 0d

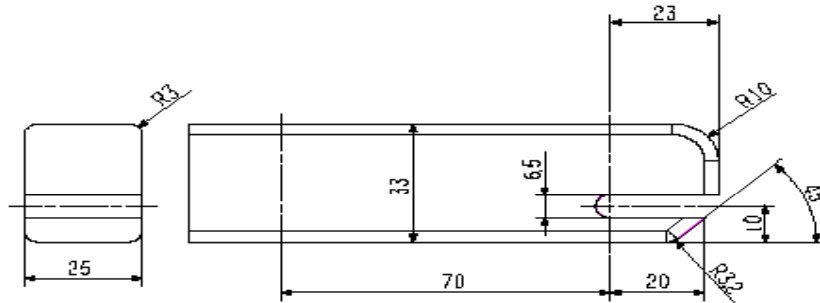

Figure 0d

Dimensions in mm

6.3.2.3. Partial latching indication

The ISOFIX child restraint system shall incorporate means by which there is a clear indication that both of the ISOFIX attachments are completely latched with the corresponding ISOFIX anchorages. The indication means may be audible, tactile or visual or a combination of two or more. In case of visual indication it must be detectable under all normal lighting conditions.

6.3.3. ISOFIX child restraint top tether strap specifications

6.3.3.1. Top tether connector

The top tether connector should be ISOFIX top tether hooks as shown in Figure 0e, or similar devices that fit within the envelope given by Figure 0e.

6.3.3.2. ISOFIX Top tether strap features

The ISOFIX top tether strap shall be supported by webbing (or its equivalent), having a provision for adjustment and release of tension.

6.3.3.2.1. ISOFIX Top tether strap length

ISOFIX Child restraint top tether strap length shall be at least 2000 mm.

6.3.3.2.2. Minimum force indicator

The ISOFIX top tether strap [shall] be equipped with a device that will indicate that a force of at least 50 N has been introduced to the strap. The device may be part of adjustment and tension relieving device.

6.3.3.2.3. Dimensions

Engagement dimensions for ISOFIX top tether hooks are shown in Figure 0e.



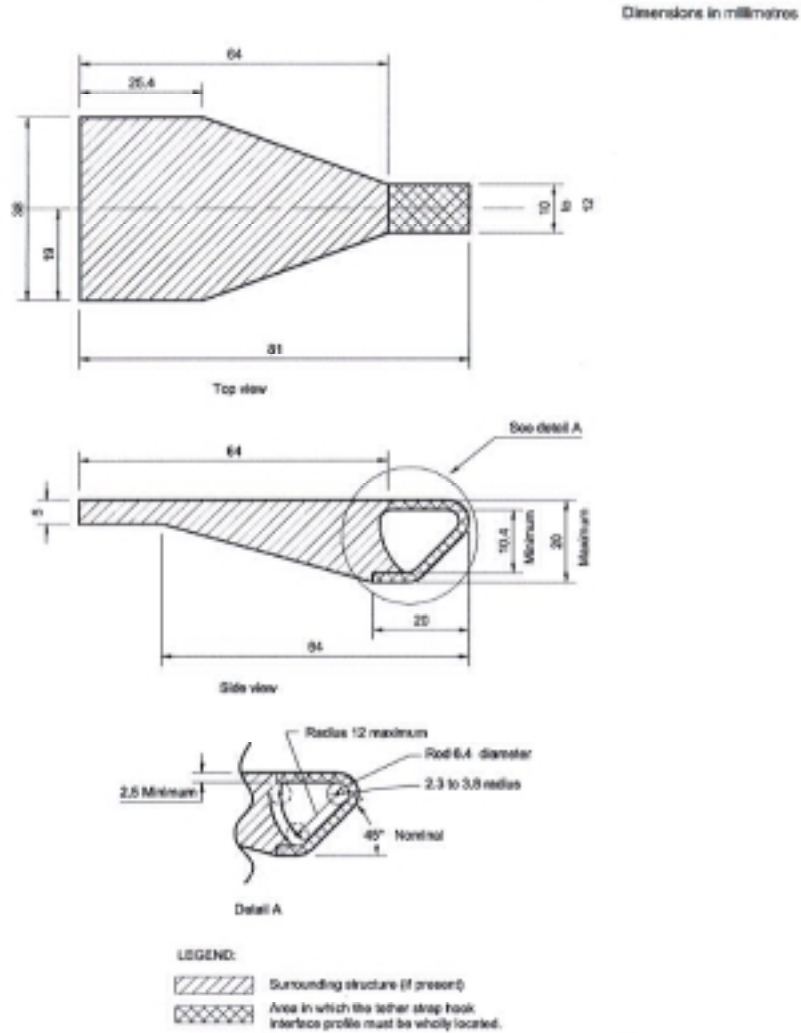

Figure 0e: ISOFIX Top tether connector (hook type) dimensions

6.3.4. Adjustment provisions

The ISOFIX attachments, or the ISOFIX child restraint system itself, shall be adjustable to accommodate the range of ISOFIX anchorage locations described in Regulation No. 14."

Insert a new paragraph 7.1.4.1.9., to read:

"7.1.4.1.9. A child restraint with a support leg shall be tested as follows:

- In the case of semi-universal category the tests shall be conducted with the support leg adjusted to both its maximum and minimum positions. During the tests the support leg shall be supported by the trolley floor pan as described in annex 6.
- In the case of support legs out of the plane of symmetry, the worst case shall be selected by the Technical Service for the tests above.

- In the case of specific vehicle category the support leg shall be adjusted as specified by the child restraint manufacturer."

**PROPOSAL B**

Insert a new paragraph 7.1.4.1.10., to read:

"7.1.4.1.10. In the case of an ISOFIX child restraint with a top tether, the dynamic tests shall be carried out under two conditions:

7.1.4.1.10.1. with the top tether strap attached, and

7.1.4.1.10.2. without the top tether strap attached."

Paragraph 7.1.4.4.1.1., figure 1, insert a reference to a footnote 5/ to the 550 dimension, and insert the corresponding footnote 5/, to read:

5/ For the purpose of the test specified in paragraph 7.1.4.1.10.1., this dimension shall be 500 mm.

**PROPOSAL C**

Insert a new paragraph 7.1.4.1.10., to read:

"7.1.4.1.10. In the case of a child restraint making use of an ISOFIX anchorage system and a top tether strap or an other anti-rotation device, the dynamic test shall be carried out under two conditions:

7.1.4.1.10.1. with the top tether strap or the anti-rotation device in function, and

7.1.4.1.10.2. without the top tether strap or the anti-rotation device in function, in which case only par. 7.1.4.1.4. has to be fulfilled."

Insert a new paragraph 7.2.6., to read:

"7.2.6. ISOFIX attachment specifications

"ISOFIX attachments" and latching indicators shall be capable of withstanding repeated operations and shall, before the dynamic test prescribed in paragraph 8.1.3., undergo a test comprising 2000 ± 5 opening and closing cycles under normal conditions of use."

Insert a new paragraph 8.1.3.7.8., to read:

"8.1.3.7.8 If the ISOFIX child restraint system must use a top tether, one test shall be carried out with the smallest dummy with the shorter distance of the top tether (anchorage point G1). A second test shall be carried out with the heavier dummy with the longer distance of the top tether (anchorage point G2). Adjust the top tether to achieve a tension load of 50 ± 5 N."

Insert a new paragraph 8.1.3.7.9., to read:

"8.1.3.7.9. The test specified in paragraph 7.1.4.1.9.2. need only be carried out with the largest manikin for which the child restraint is designed."

**PROPOSAL D**

Paragraph 8.2.4.3.4., the reference to footnote 5/, and footnote 5/ (former), renumber as footnote 6/.

Insert a new paragraph 14.2.11., to read:

"14.2.11. For an ISOFIX child restraint system the following label shall be clearly visible at the point of sale without removing the packing:

**NOTICE**

1. This is an ISOFIX CHILD RESTRAINT SYSTEM. It is approved to Regulation No. 44-04 series of amendments for general use in vehicles fitted with ISOFIX anchorages systems.
2. It will fit vehicles with positions approved as ISOFIX positions (as detailed in the vehicle handbook), depending on the category of the child seat and of the fixture.
3. The weight group and the ISOFIX size class for which this device is intended shall be indicated.

"

Paragraph 14.3.1., amend to read:

"14.3.1. The weight groups and the fixture for which the device is intended"

Insert a new paragraph 14.3.14., to read:

"14.3.18. For an ISOFIX child restraint system, the instruction for use must be given to read the car manufacturer book."

Annex 6,

Paragraph 1.1., amend to read:

"1.1. For tests on child restraint systems, the trolley, carrying the ... For tests on child restraint systems in the vehicle specific category the trolley with the ...."

Insert new paragraphs 3.3 to 3.3.1.5., to read:

"3.3. Trolley floor pan

3.3.1. The floor pan of the trolley shall be constructed of a flat sheet of metal of uniform thickness and material , see figure 2 of appendix 3 to this annex.

3.3.1.1. The floor pan shall be rigidly mounted on the trolley. The height of the floor pan relative to the CR-point, dimension X in figure 2, shall be adjusted to meet the requirements of paragraph 7.1.4.1.9.

3.3.1.2. The floor pan shall be designed so that the surface hardness should not be below 120 HB, according to EN ISO 6506-1:1999.

- 3.3.1.3. The floor pan shall withstand an applied vertical concentrated load of 5 kN without causing a vertical movement greater than 2 mm referring to Cr and without any permanent deformation occurring.
- 3.3.1.4. The floor pan shall have a surface roughness not exceeding Ra 6,3 according to ISO 4287:1997.
- 3.3.1.5. The floor pan shall be designed so that no permanent deformation is occurring after a dynamic test of a child restraint system, according to this Regulation."

Annex 6, appendix 3,

Paragraph 1., amend to read:

- "1. The anchorages shall be positioned as shown in the figures 1, 2 and 3 below."

Paragraphs 2.1. and 2.2., amend to read:

- "2.1. For child restraint **using** lap belts, points A and B;
- 2.2. For child restraint **using** lap and diagonal belts, points A, BO and C."

Insert a new paragraph 2.3., to read:

- "2.3. **For child restraints using ISOFIX attachment, rearmost point H<sub>1</sub> and H<sub>2</sub>.**"

Paragraphs 3. and 4., amend to read:

- "3. Anchorages A, B **and/or (rearmost) H<sub>1</sub> H<sub>2</sub>** and D shall be used .... upper anchorage.
4. Anchorages A, B **and/or (rearmost) H<sub>1</sub> H<sub>2</sub>,** E and F shall be used .... upper anchorages."

Paragraph 8., amend to read:

8. For testing of child restraints
- in the "universal" and "restricted" categories, a standard retractor belt, as specified in annex 13,
  - **in the ISOFIX "universal category" an ISOFIX anchorages system and ISOFIX top tether anchorage as described in paragraphs 5.2.3.1. and 5.2.4.4. of Regulation No. 14, shall be fitted to the test seat,**
  - **In the ISOFIX "semi-universal" category an ISOFIX anchorages system as described in paragraph 5.2.3.1. of Regulation No. 14 and ISOFIX top tether anchorage as described in paragraph 5.2.4.4. of Regulation No. 14 or the dashboard and the floor pan as described in annex 6, paragraphs 3.2. and 3.3."**

Insert a new paragraph 9., to read:

- "9. For testing of child restraints with top tether, the anchorage G<sub>1</sub> or G<sub>2</sub> shall be used."

Insert a new paragraph 10., to read:

"10. In the case of child restraints utilising a support leg, the technical service shall select the anchorages to be used according to paragraphs 2., 3., 4. or 5. above and with the support leg adjusted as specified in paragraph 7.1.4.1.9."

Figure 2, amend to read

"

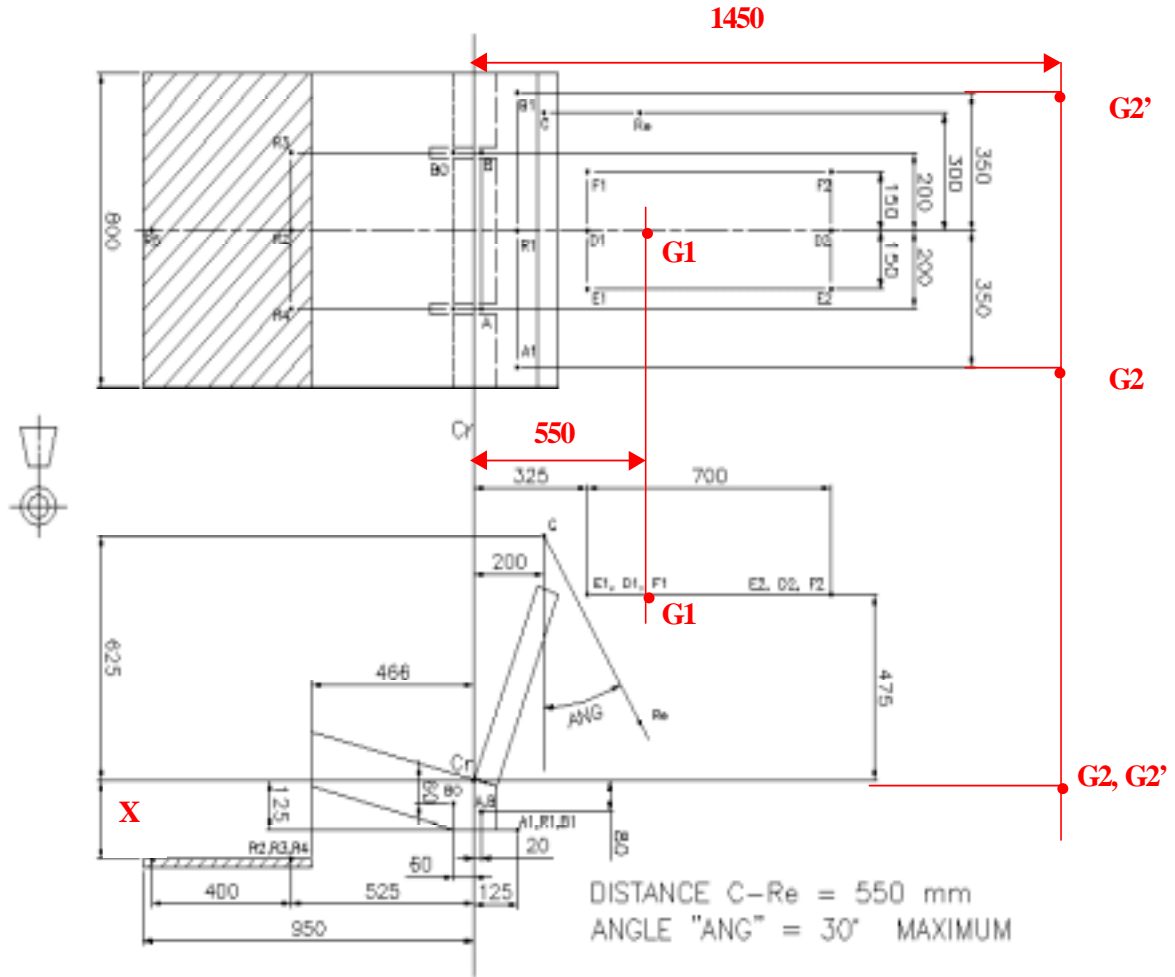

Figure 2

FLOOR AREA IS HATCHED

"

Figure 3, amend to read:

"

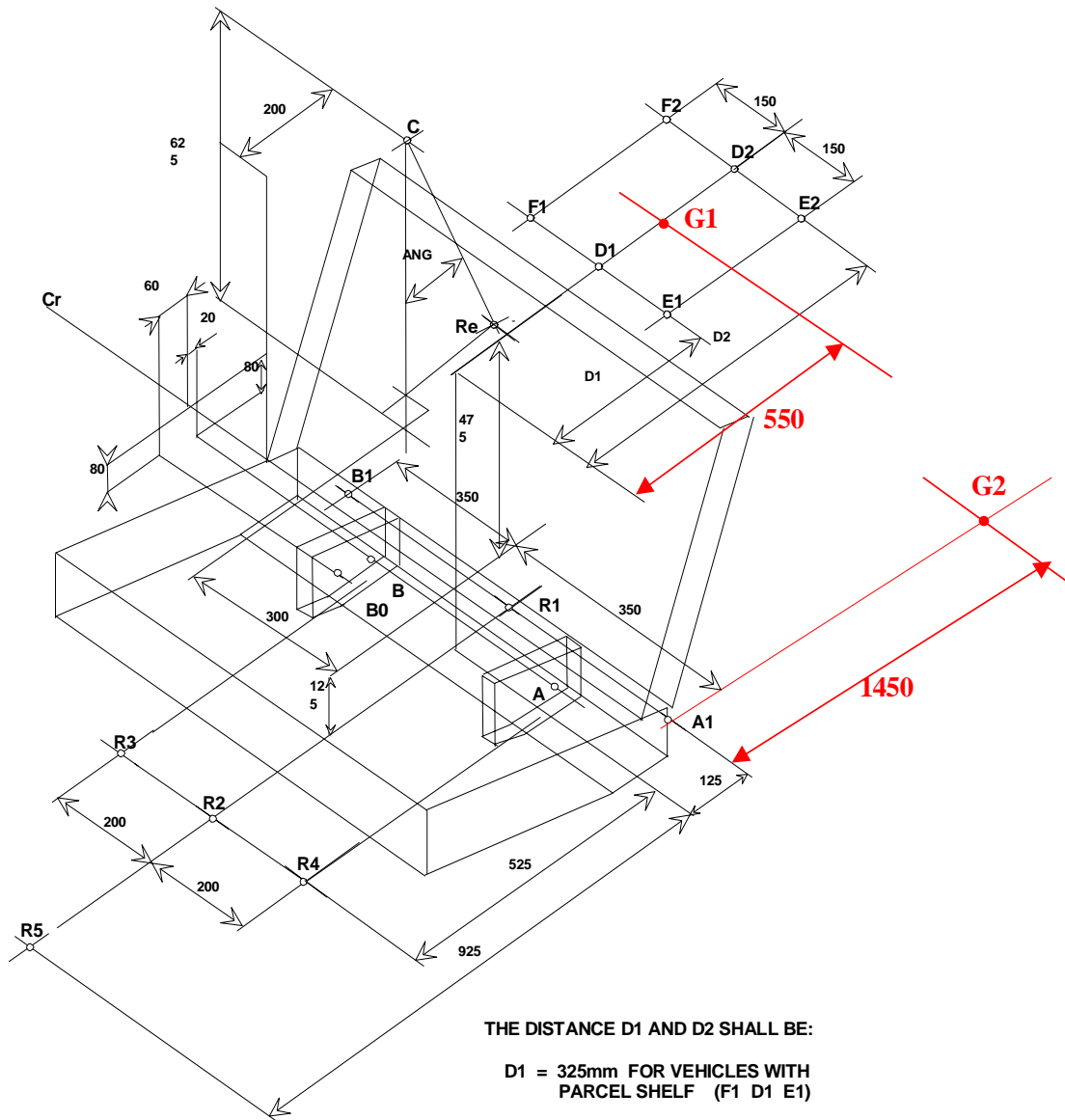

DIMENSIONS REFERRING TO Cr  
ARE TOLERANCED WITH:  $\pm 2$  mm  
EXCEPT FOR DISTANCE FLOOR TO Cr  $\pm 10$ mm

DISTANCE C - Re = 550mm  
ANGLE "ANG" = 30° MAXIMUM

THE DISTANCE D1 AND D2 SHALL BE:

D1 = 325mm FOR VEHICLES WITH  
PARCEL SHELF (F1 D1 E1)

D1 = 1025mm FOR VEHICLES WITH  
FOLDING BACK REAR SEATS  
(ESTATE TYPE) (F2 D2 E2)

Figure 3

"

Annex 8, appendix 3, paragraph 3.2.1., table 2, insert the missing row 13, to read:

"....."

13	neck width	65
----	------------	----

....."

**Annex 11, footnote 1/, amend to read:**

"1/ See text of Regulation No. 16."

Annex 21,

The figure, amend to read:

"

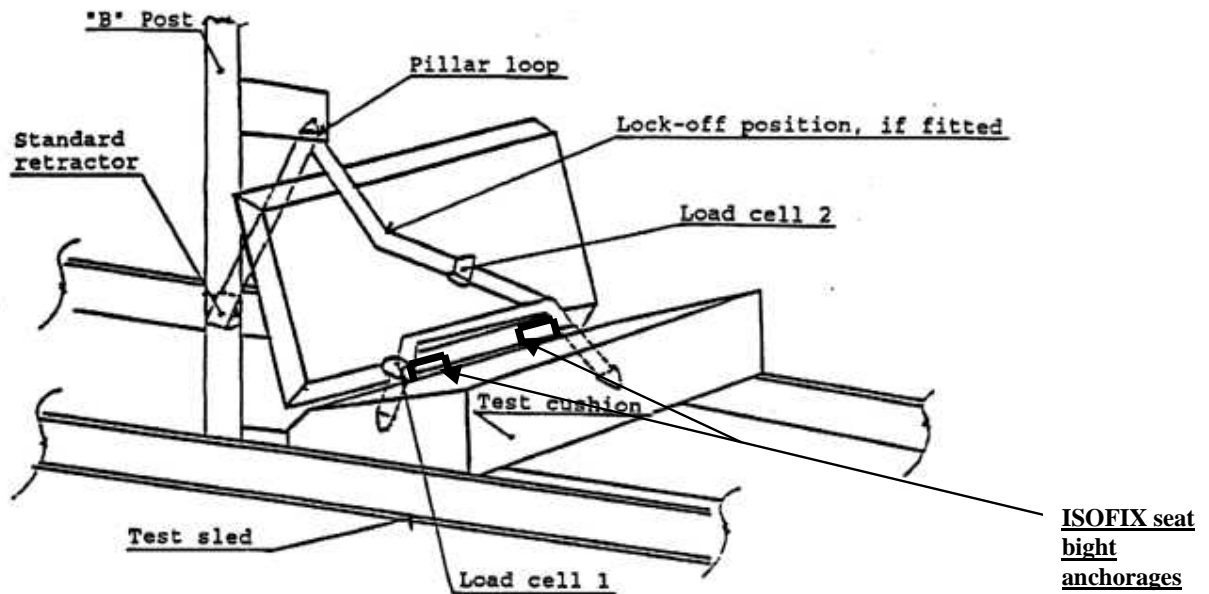

"

Paragraph 1.2.3., amend to read:

"1.2.3. Extract all webbing from the retractor spool and allow the tension in the belt between the retractor and pillar loop to drop to the retractor tension. The spool shall be locked before the dynamic test."

Insert a new paragraph 1.3., to read:

"1.3. ISOFIX attachment

For an ISOFIX child restraint system with adjustable position seat bight ISOFIX anchorages. Attach the unladen ISOFIX child restraint system onto the seat bight anchorages H1-H2 in the appropriate test position. Allow the ISOFIX child restraint latch mechanisms to pull the unladen ed ISOFIX child restraint system towards the seat bight. Apply an additional force of  $135 \pm 15$  N

in a plane parallel to the test bench seat cushion surface in the direction of the seat bight to overcome frictional forces between the ISOFIX child restraint system and the seat cushion, assisting the self-tensioning effects of the latch mechanism. The force shall be applied on or equally about the centreline of the ISOFIX child restraint and at a height not more than 100 mm above the test bench cushion surface. If needed, adjust the top tether to achieve a tension load of  $50 \pm 5$  N (1/). Place appropriate test dummy in child restraint when the ISOFIX child restraint system has been so adjusted.

**Note 1/:** In the case of restraints fitted with devices intended to increase the top tether tension, the test method shall be: Install the ISOFIX child restraint system as required in this annex and then apply the tensioner device as stated in the manufacturers instructions. If the device cannot be applied due to excess tension then it is deemed to be an unacceptable device."

Note 1/, amend to read:

"1. Installation is conducted after fitting the manikin into the restraint **for paragraphs 1.1. and 1.2.**"

---