



Secretariat

Distr.
GENERAL

ST/SG/AC.10/C.3/2000/21
17 April 2000

Original: ENGLISH

**COMMITTEE OF EXPERTS ON THE TRANSPORT
OF DANGEROUS GOODS**

**Sub-Committee of Experts on the
Transport of Dangerous Goods**
(Eighteenth session, 3-14 July 2000,
agenda item 5 (i))

**MISCELLANEOUS DRAFT AMENDMENTS TO THE MODEL REGULATIONS
ON THE TRANSPORT OF DANGEROUS GOODS**

Explosives

**Report from the informal working group on classification of ammonium nitrate emulsions,
intermediate for blasting explosives**

Transmission by the Chairman of the Working Group

1. Introduction

An informal working group was hosted by the Federation of European Explosives Manufacturers (FEEM) in Engene, Norway from 4 to 8 October 1999. Representatives from authorities, laboratories and industry from Canada, France, Germany, the Netherlands, Norway, Poland, South Africa, Sweden, UK and USA participated in the meeting. Mr. Johansen (Norway) was elected chairman and Mr. De Jong (Netherlands) secretary.

The following documents were considered:

- ST/SG/AC.10/1998/45 (France)
- ST/SG/AC.10/C.3/1999/34 (Canada)
- ST/SG/AC.10/C.3/1999/47 (Norway)
- UN/SCETDG/16/INF9 (OECD-IGUS)

GE.00-

During the meeting the following information papers were distributed and considered:

- Information Provided for Discussion (USA)
- Ammonium Nitrate Matrices, Discussion Paper (Sweden)
- Ammonium Nitrate Based Emulsions, Discussion Paper (UK)
- French rules for transport of AN emulsion matrices (France)
- AEMSC Submission to UNCETDG intersessional working group meeting (Australia)

The mandate given by the Sub-Committee of Experts on the Transport of Dangerous Goods was:

- to determine appropriate classification criteria,
- to analyse the properties of the emulsions so as to determine test methods that could be used classifying them,
- to analyse the need for a new test method to better assess the explosive properties of such emulsions, and
- to propose conditions for carriage, in particular packagings, tanks or IBCs, as appropriate for each type.

The group first considered the general composition of the products believed to be candidates for an entry outside Class 1.

In the discussions, the following properties were considered in order to describe the emulsions (in random order):

1. physical state, presence of solid additives?
2. sensitised versus non sensitised
3. "water in oil emulsions"
4. nitrates only or other salts as well?
5. temperature during transport
6. viscosity
7. density
8. degree of mixing
9. impurities
10. type of oil
11. flash point of the oil

After discussion and exchange of available information the following range of formulations was agreed:

60 – 85 % ammonium nitrate (part of the AN may be replaced by other inorganic nitrate salts)
5 – 30 % water
2 – 8 % oil
0.5 – 4 % emulsifier
0 – 10 % soluble flame suppressants
and trace additives

This resulted in the following definition:

“Non sensitised emulsion primarily consisting of a solution of ammonium nitrate dispersed in an oil phase, intended to produce a Type E blasting explosive only after further processing prior to use. The emulsion typically has the following composition: 60 – 85 % ammonium nitrate; 5 – 30 % water; 2 – 8 % oil; 0.5 – 4 % emulsifier, 0 – 10 % soluble flame suppressants and trace additives. Part of the ammonium nitrate may be replaced by other inorganic nitrate salts.”

Based on the original proposal in the documents from France and Norway, the working group agreed on proposing the following proper shipping name:

“ AMMONIUM NITRATE EMULSION, intermediate for blasting explosives”

for a new entry in Division 5.1. The allocation of this entry to Division 5.1 was made subject to the prerequisite of having a proper Test Series to assess the safety properties of the substance. The following test were identified:

- Cap Sensitivity Test
- Koenen Test
- Modified USA DDT Test (*Test 5(b)(ii) with a 20 gram igniter*)
- USA Vented pipe test
- Thermal stability test:

The group tentatively agreed to introduce the proposed USA Vented Pipe Test intended to address the concern of transporting this material in bulk. The heat source should be the same as specified in the (revised) 6(c) test. Examples of results needs to be added as well. Canada volunteered to run tests to characterise the test method further to see whether the test is capable of distinguishing between a 5.1 and a 1.5 substance. France was of the opinion that a DDT test would properly establish the detonation properties and may avoid the need for any large scale detonation tests. The Netherlands offered to perform tests with the modified USA DDT test on characteristic samples provided by industry to increase confidence in the test.

If the substance does not meet the criteria set up for the tests, then the product should be a candidate for inclusion in Class 1, Division 1.5D or 1.1D.

Test conditions: as offered for transport (see 1.5.4 of the Manual of Tests and Criteria.)

After extensive discussion the group agreed on the following proposal for a new entry and related test methods:

2. Proposal

(a) In the Dangerous Goods List of Chapter 3.2, create a new entry:

UN No.	Name and description	Class or division	Subsidiary risk	UN Packing Group	Special provisions	Limited Quantities	Packagings and IBCs		Portable tanks	
							PI	SPP	PTI	TP
(1)	(2)	(3)	(4)	(5)	(6)	(7)	(8)	(9)	(10)	(11)
3XXX	AMMONIUM NITRATE EMULSION, intermediate for blasting explosives	5.1		III	yyy	None	P503 IBC02		T2	TP17 TPxy

(b) In Chapter 3.3 create a new Special Provision yyy:

“This entry applies to non sensitised emulsions consisting primarily of a solution of ammonium nitrate dispersed in an oil phase, intended to produce a Type E blasting explosive only after further processing prior to use. The emulsion typically has the following composition: 60 – 85 % ammonium nitrate; 5 – 30 % water; 2 – 8 % oil; 0.5 – 4 % emulsifier, 0 – 10 % soluble flame suppressants and trace additives. Part of the ammonium nitrate may be replaced by other inorganic nitrate salts. Formulations shall satisfactorily pass Test Series 8 in the Manual of Tests and Criteria, Part I, Section 18.”

(c) In subsection 4.2.4.3 add a new portable tank special provision TP xy:

“Metal tanks shall have frangible disks and/or fusible elements with a total relief area of at least [0.005 m²/m³]. To avoid unnecessary confinement only tank types with a maximum allowable working pressure (MAWP) of not more than 2.65 bar shall be used.”

(d) In subsection 4.1.4.2 Packing Instruction IBC02, add Special Packing Provision B yz:

“ For UN 3XXX, metal IBCs shall have frangible disks and/or fusible elements with a total relief area of at least [0.005 m²/m³].”

Changes to be made to the Manual of Tests and Criteria:

(e) Make the following changes to Figure 10.2.

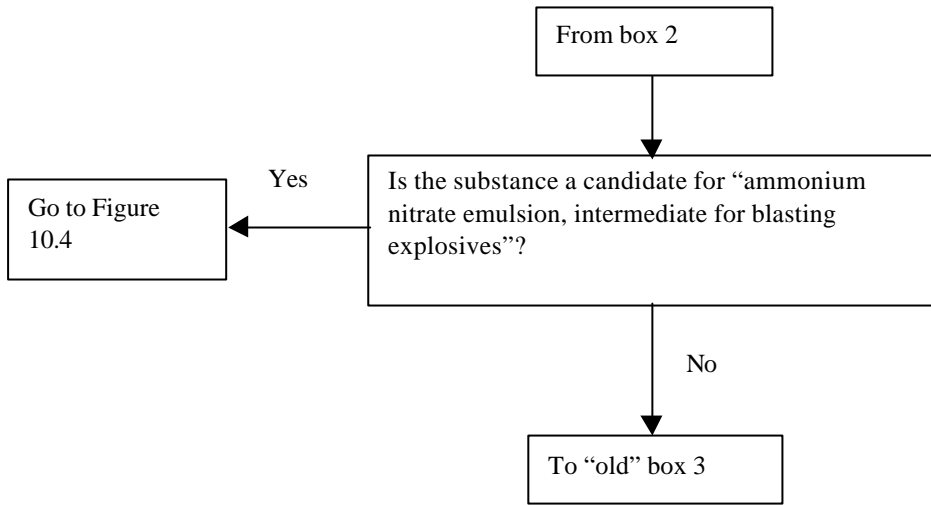

(f) Add new Table 10.4:

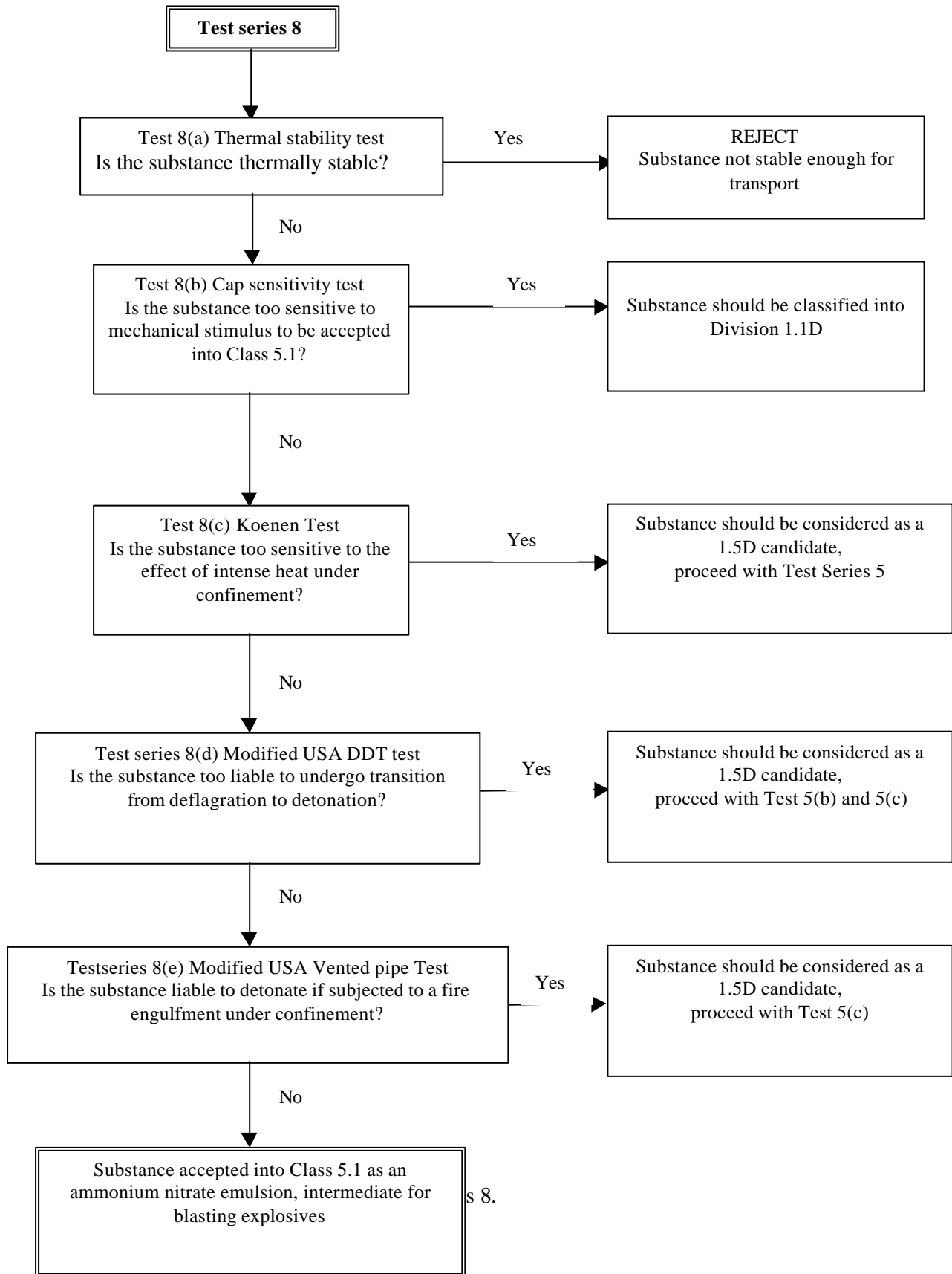

SECTION 18

TEST SERIES 8

18.1 Introduction

The assessment whether a candidate for “ammonium nitrate emulsion, intermediate for blasting explosives” is insensitive enough for inclusion in Division 5.1 is answered by series 8 tests and any such candidate for inclusion in Division 5.1 should pass each of the five types of tests comprising the series. The five test types are:

type 8(a) - a test to determine the thermal stability;

type 8 (b) - a shock test to determine sensitivity to intense mechanical stimulus;

type 8 (c) - a test to determine the effect of heating under confinement;

type 8 (d) - a thermal test to determine the tendency of transition from deflagration to detonation; and

type 8 (e) - a test to determine the effect of exposure to a large fire under confined, vented conditions.

18.2 Test methods

The test methods currently used are listed in table 18.1.

Table 18.1: TEST METHODS FOR TEST SERIES 8

Test code	Name of Test	Section
8 (a)	Thermal stability test <u>*/</u>	18.4.1
8 (b)	Cap sensitivity test <u>*/</u>	18.4.2
8 (c)	Koenen test <u>*/</u>	18.4.3
8 (d)	Modified USA DDT test <u>*/</u>	18.4.4
8 (e)	USA vented pipe test <u>*/</u>	18.4.5

*/ Recommended test

18.3 Test conditions

18.3.1 The substance should be tested as offered for transport, at the highest transport temperature (see 1.5.4 of this Manual).

18.4 Test Series 8 test description**18.4.1 Test 8(a) Thermal stability test****18.4.1.1 Introduction**

This test is used to measure the stability of a candidate ammonium nitrate emulsion, intermediate for blasting explosive, when subjected to elevated thermal conditions to determine if the substance is too dangerous to transport.

18.4.1.2 Apparatus and materials

18.4.1.2.1 The following apparatus is required:

- (a) An electric oven equipped with ventilation, explosion-proof electrical features, and thermostatic control adequate to maintain and record the temperature at 75 ± 2 °C. The oven should have dual thermostats or some kind of protection against thermal run-away if the thermostat malfunctions.
- (b) A lipless beaker of 35 mm diameter and 50 mm high and a watch-glass of 40 mm diameter.
- (c) A balance capable of determining the sample weight to ± 0.1 g.
- (d) Three thermocouples and a recording system.
- (e) Two flat-bottomed glass tubes of 50 ± 1 mm diameter and 150 mm length and two 0.6 bar (60 kPa) pressure resisting stoppers.

18.4.1.2.2 An inert substance, whose physical and thermal properties are similar to the test substance, should be used as the reference substance.

18.4.1.3 Procedure

18.4.1.3.1 ***In dealing with a new substance, several screening tests, involving heating small samples at 75 °C for 48 hours, are performed to explore its behaviour.*** If no explosive reaction occurs using a small amount of substance, the procedure given in 18.8.1.3.2 or 18.8.1.3.3 should be used. If explosion or ignition occurs then the substance is too thermally unstable for transport.

18.4.1.3.2 Uninstrumented test: A 50 g sample is weighed into a beaker, covered and placed in an oven. The oven is heated to 75 °C and the sample left at oven temperature for 48 hours or until ignition or explosion occurs, whichever is sooner. If ignition or explosion does not occur but there is evidence, e.g. fuming or decomposition, that some self-heating has occurred, the procedure given in 18.4.1.3.3 should be performed. However, if the substance shows no evidence of thermal instability, it may be regarded as thermally stable and no further testing of this property is necessary.

18.4.1.3.3 Instrumented test: A 100 g (or 100 cm³ if the density is less than 1000 kg/m³) sample is placed in one tube and the same quantity of reference substance is placed in the other. Thermocouples T₁ and T₂ are inserted into the tubes at half-height of the substances. If the thermocouples are not inert with respect to both the substance being tested and the reference substance, they should be enclosed in sheaths

which are inert. Thermocouple T_3 and the covered tubes are placed in the oven as shown in figure 18.4.1.1. The temperature difference (if any) between test sample and reference is measured for 48 hours after the sample and any reference substance reach 75 °C. Evidence of decomposition of the sample is noted.

18.4.1.4 *Test criteria and method of assessing results*

18.4.1.4.1 The result from an uninstrumented test is considered "+" if ignition or explosion occurs and "—" if no changes are observed. The result of a instrumented test is considered "+" if an ignition or explosion occurs or if a temperature difference (i.e. self-heating) of 3 °C or greater is recorded. If no ignition or explosion occurs but self-heating of less than 3 °C is noted, additional tests and/or evaluation may be required to determine if the sample is thermally unstable.

18.4.1.4.2 If the test result is "+", the substance should be considered too thermally unstable for transport.

18.4.1.5 *Examples of results*

Substance	Observations	Result
to be added		

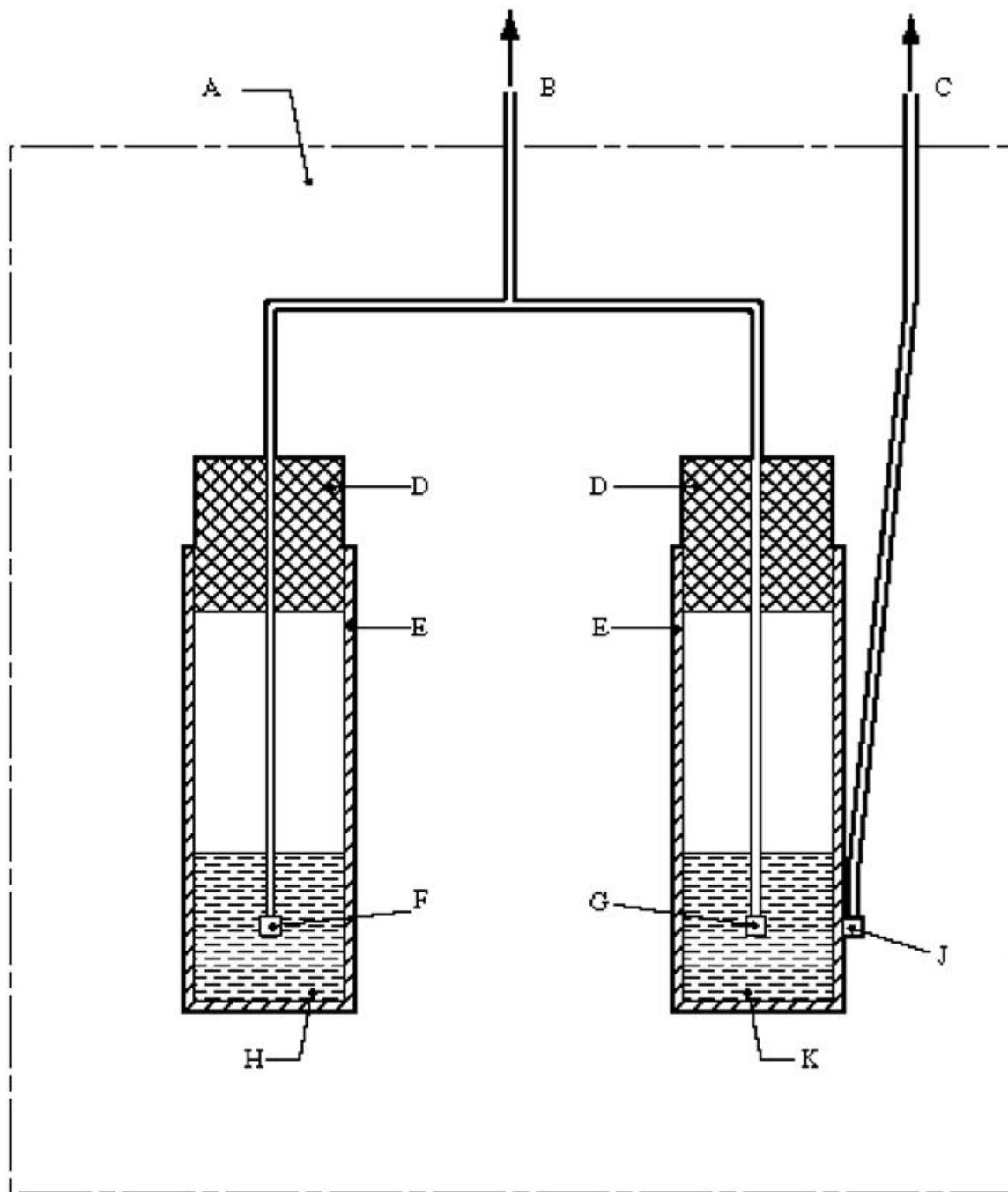

(A)	Heating oven	(B)	To millivoltmeter ($T_1 - T_2$)
(C)	To millivoltmeter (T_3)	(D)	Stoppers
(E)	Glass tubes	(F)	Thermocouple No 1 (T_1)
(G)	Thermocouple No 2 (T_2)	(H)	100 cm ³ of sample
(J)	Thermocouple No 3 (T_3)	(K)	100 cm ³ of reference substance

Figure 18.4.1.1: EXPERIMENTAL SET-UP FOR STABILITY TEST AT 75 °C

18.4.2 *Test 8 (b): Cap sensitivity test*

18.4.2.1 *Introduction*

This shock test is designed to determine the sensitivity of a candidate ammonium nitrate emulsion, intermediate for blasting explosive, to intense mechanical stimulus.

18.4.2.2 *Apparatus and materials*

The experimental set up for the cap sensitivity test is shown in figures 18.4.2.1 and 18.4.2.2 and consists of a cardboard tube of minimum diameter 80 mm and length 160 mm with a maximum wall thickness of 1.5 mm, closed at the base with a membrane just sufficient to retain the sample. The intense mechanical stimulus is provided by a standard detonator (see appendix 1) inserted centrally in the top of the sample in the tube to a depth equal to its length. Below the tube is the witness, which consists of a 1.0 mm thick 160 H 160 mm steel plate, placed on a steel ring of 50 mm height, 100 mm inner diameter and 3.5 mm wall thickness (see figure 18.4.2.1). Alternatively, a 51 mm diameter, 102 mm long cylinder of common (soft) lead (see figure 18.4.2.2) may be used. The apparatus is placed onto a square shaped steel plate of 25 mm thickness and 152 mm sides.

18.4.2.3 *Procedure*

The substance under test is filled into the tube in three equal increments. The substance is carefully packed to prevent adding voids. The final density of the sample in the tube should be as close as possible to its shipping density. The tube is placed onto the witness and steel base plate and the standard detonator inserted centrally into the top of the sample. The detonator is then fired from a safe position and the witness examined. The test is conducted three times unless detonation of the substance occurs.

8.4.2.4 *Test criteria and method of assessing results*

The result is considered "+" and the substance should not be classified in Division 5.1 if in any trial:

- (a) the witness plate is torn or otherwise penetrated (i.e. light is visible through the plate) - bulges, cracks or folds in the witness plate do not indicate cap sensitivity; or
- (b) the centre of the lead cylinder is compressed from its initial length by an amount of 3.2 mm or greater.

Otherwise, the result is considered "—".

18.4.2.5 *Examples of results*

Substance	Density (kg/m ³)	Remarks	Result
to be added			

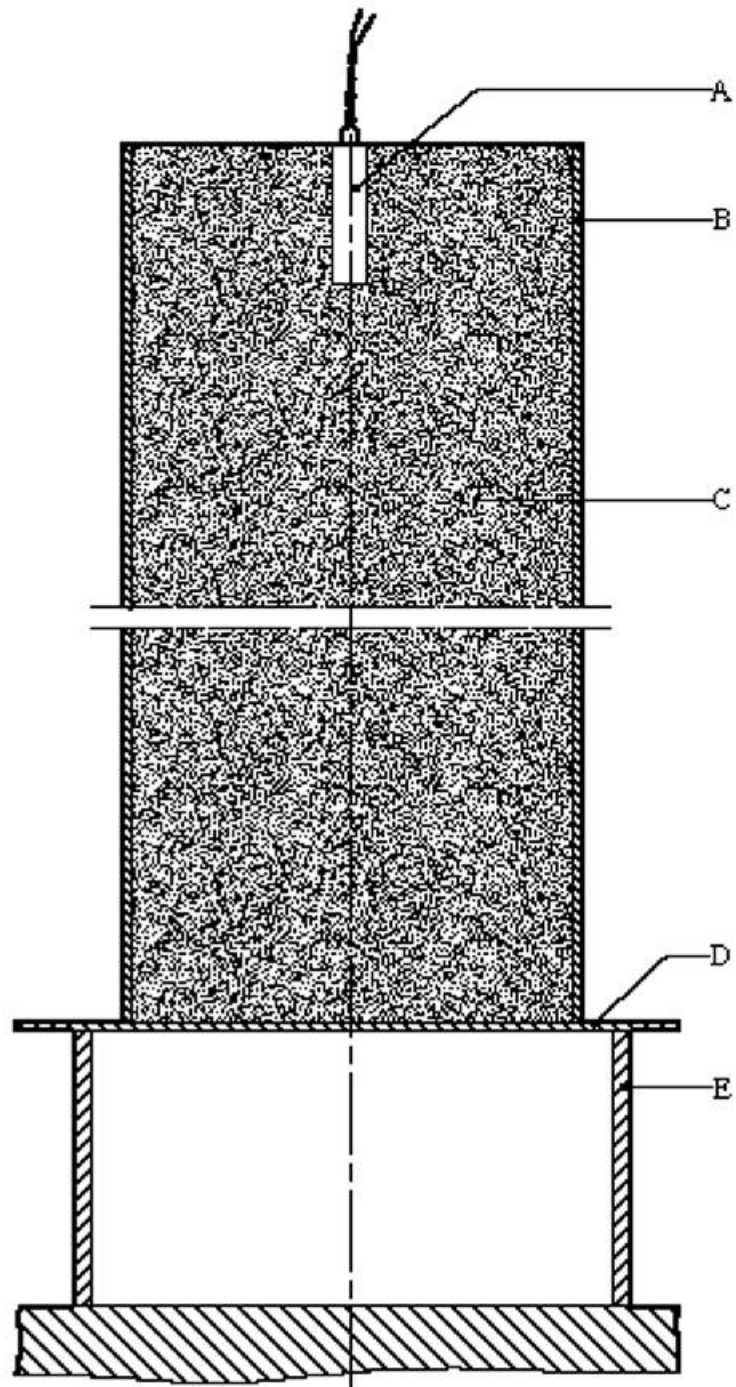

-
- | | | | |
|-----|----------------|-----|--|
| (A) | Detonator | (B) | Tube fibreboard spirally wound plys |
| (C) | Test substance | (D) | Witness plate of normal structural steel |
| (E) | Steel ring | | |
-

Figure 18.4.2.1: CAP SENSITIVITY TEST (using steel witness plate)

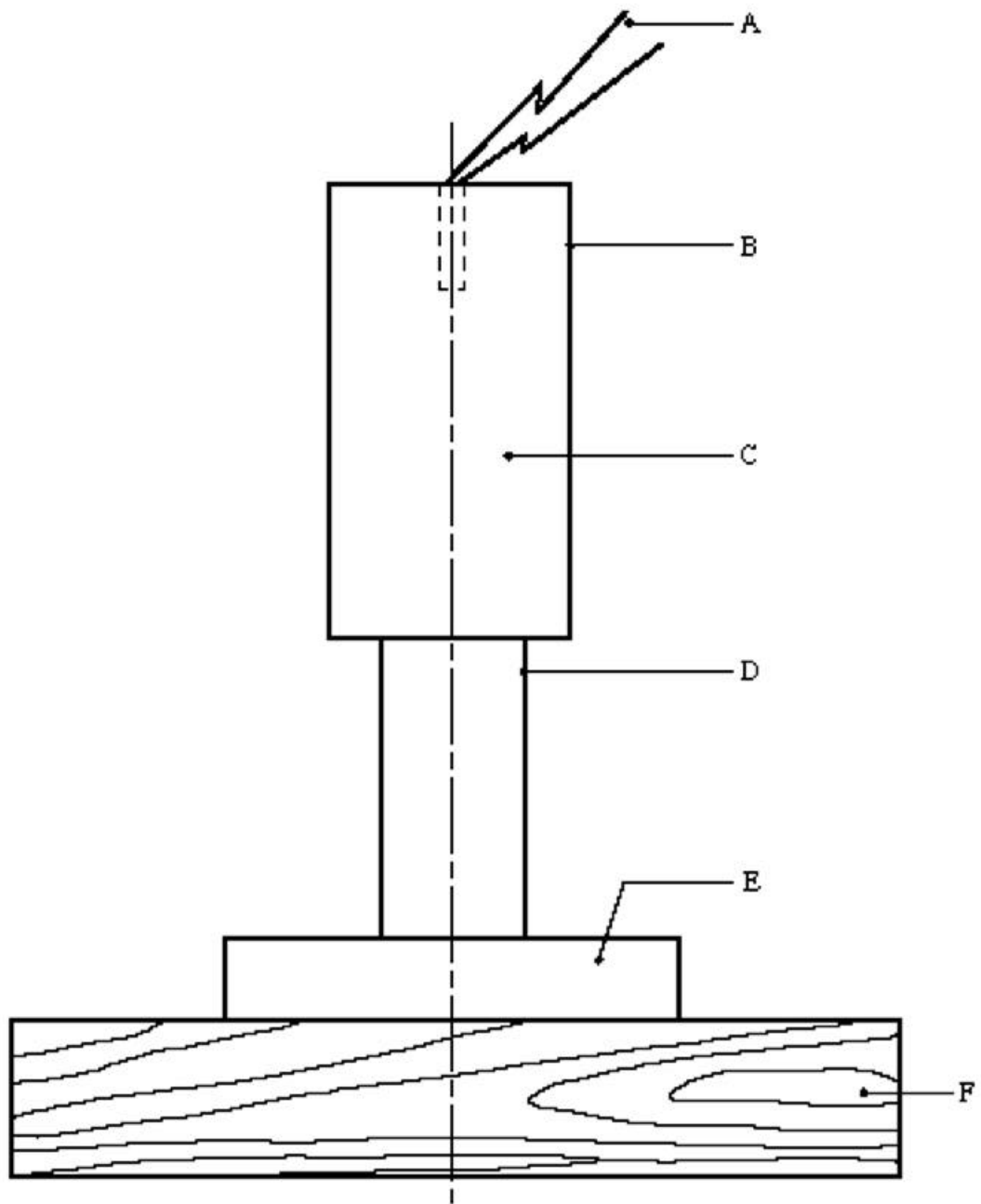

-
- (A) Electric detonator
 - (B) Cardboard container 8.6 cm diameter x 16.2 cm long
 - (C) Test substance
 - (D) Lead cylinder
 - (E) Steel plate 15 x 15 x 2.5 cm
 - (F) Wood block 30 x 30 x 5 cm
-

18.4.3 **Figure 18.4.2.2: CAP SENSITIVITY TEST (using lead cylinder as witness)**
Test 8(c): Koenen test

18.4.3.1 *Introduction*

This test is used to determine the sensitiveness of a candidate ammonium nitrate emulsion, intermediate for blasting explosive, to the effect of intense heat under high confinement.

18.4.3.2 *Apparatus and materials*

18.4.3.2.1 The apparatus consists of a non-reusable steel tube, with its re-usable closing device, installed in a heating and protective device. The tube is deep drawn from sheet steel of suitable quality. The mass of the tube is 25.5 ± 1.0 g. The dimensions are given in figure 18.4.3.1.1. The open end of the tube is flanged. The closing plate with an orifice, through which the gases from the decomposition of the test substance escape, is made from heat-resisting chrome steel and is available with the following diameter holes: 1.0 - 1.5 - 2.0 - 2.5 - 3.0 - 5.0 - 8.0 - 12.0 - 20.0 mm. The dimensions of the threaded collar and the nut (closing device) are given in figure 18.4.3.1.1.

18.4.3.2.2 Heating is provided by propane, from an industrial cylinder fitted with a pressure regulator, via a flow meter and distributed by a manifold to the four burners. Other fuel gases may be used providing the specified heating rate is obtained. The gas pressure is regulated to give a heating rate of 3.3 ± 0.3 K/s when measured by the calibration procedure. Calibration involves heating a tube (fitted with a 1.5 mm orifice plate) filled with 27 cm³ of dibutyl phthalate. The time taken for the temperature of the liquid (measured with a 1 mm diameter thermocouple centrally placed 43 mm below the rim of the tube) to rise from 50 °C to 250 °C is recorded and the heating rate calculated.

18.4.3.2.3 Because the tube is likely to be destroyed in the test, heating is undertaken in a protective welded box, the construction and dimensions of which are given in figure 18.4.3.1.2. The tube is suspended between two rods placed through holes drilled in opposite walls of the box. The arrangement of the burners is given in figure 18.4.3.1.2. The burners are lit simultaneously by a pilot flame or an electrical ignition device. ***The test apparatus is placed in a protective area.*** Measures should be taken to ensure that the burner flames are not affected by any draughts. Provision should be made for extracting any gases or smoke resulting from the test.

18.4.3.3 *Procedure*

18.4.3.3.1 The substance is loaded into the tube to a height of 60 mm taking particular care to prevent the formation of voids. The threaded collar is slipped onto the tube from below, the appropriate orifice plate is inserted and the nut tightened by hand after applying some molybdenum disulphide based lubricant. It is essential to check that none of the substance is trapped between the flange and the plate, or in the threads.

18.4.3.3.2 With orifice plates from 1.0 mm to 8.0 mm diameter, nuts with an orifice of 10.0 mm diameter should be used; if the diameter of the orifice is above 8.0 mm, that of the nut should be 20.0 mm. Each tube is used for one trial only. The orifice plates, threaded collars and nuts may be used again provided they are undamaged.

18.4.3.3.3 The tube is placed in a rigidly mounted vice and the nut tightened with a spanner. The tube is then suspended between the two rods in the protective box. The test area is vacated, the gas supply turned on and the burners lit. The time to reaction and duration of reaction can provide additional information useful in interpreting the results. If rupture of the tube does not occur, heating is to be continued for at least five minutes before the trial is finished. After each trial the fragments of the tube, if any, should be collected and weighed.

18.4.3.3.4 The following effects are differentiated:

- "O": Tube unchanged;
- "A": Bottom of tube bulged out;
- "B": Bottom and wall of the tube bulged out;
- "C": Bottom of tube split;
- "D": Wall of tube split;
- "E": Tube split into two ^{*}/ fragments;
- "F": Tube fragmented into three ^{*}/ or more mainly large pieces which in some cases may be connected with each other by a narrow strip;
- "G": Tube fragmented into many mainly small pieces, closing device undamaged; and
- "H": Tube fragmented into many very small pieces, closing device bulged out or fragmented.

Examples for the effect types "D", "E" and "F" are shown in figure 18.4.3.1.3. If a trial results in any of the effects "O" to "E", the result is regarded as "no explosion". If a trial gives the effect "F", "G" or "H", the result is evaluated as "explosion".

18.4.3.3.5 The series of trials is started with a single trial using an orifice plate of 20.0 mm. If, in this trial, the result "explosion" is observed, the series is continued with trials using tubes without orifice plates and nuts but with threaded collars (orifice 24.0 mm). If at 20.0 mm "no explosion" occurs, the series is continued with single trials using plates with the following orifices 12.0 - 8.0 - 5.0 - 3.0 - 2.0 - 1.5 and finally 1.0 mm until, at one of these diameters, the result "explosion" is obtained. Subsequently, trials are carried out at increasing diameters, according to the sequence given in 18.4.3.2.1, until only negative results in three tests at the same level are obtained. The limiting diameter of a substance is the largest diameter of the orifice at which the result "explosion" is obtained. If no "explosion" is obtained with a diameter of 1.0 mm, the limiting diameter is recorded as being less than 1.0 mm.

18.4.3.4 *Test criteria and method of assessing results*

The result is considered "+" and the substance should not be classified in Division 5.1 if the limiting diameter is 2.0 mm or more. The result is considered "—" if the limiting diameter is less than 2.0 mm.

18.4.3.5 *Examples of results*

Substance	Result
to be added	

^{*}/ The upper part of the tube remaining in the closing device is counted as one fragment.

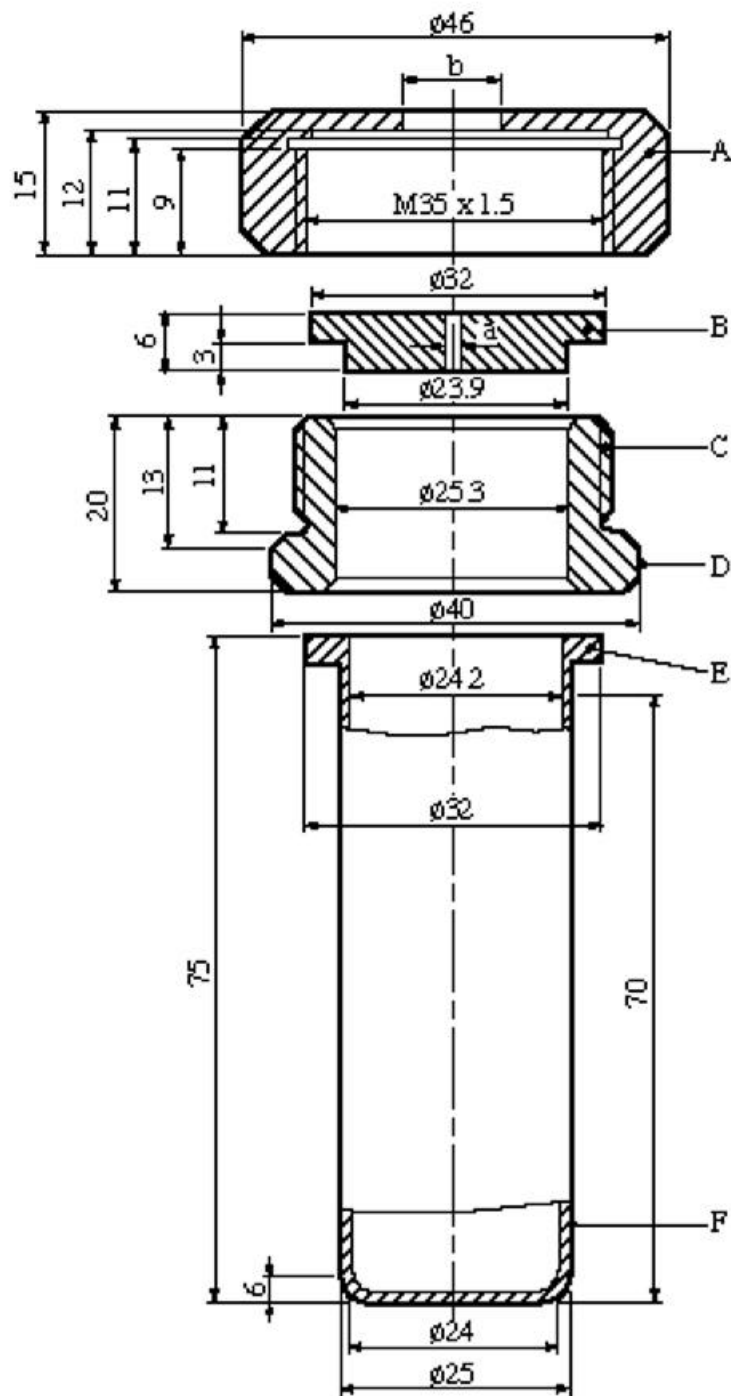

- | | | | |
|-----|---|-----|---|
| (A) | Nut (b = 10.0 or 20.0 mm)
with flats for size 41 spanner | (B) | Orifice plate
(a = 1.0 6 20.0 mm diameter) |
| (C) | Threaded collar | (D) | Flats for size 36 spanner |
| (E) | Flange | (F) | Tube |

Figure 18.4.3.1.1: TEST TUBE ASSEMBLY

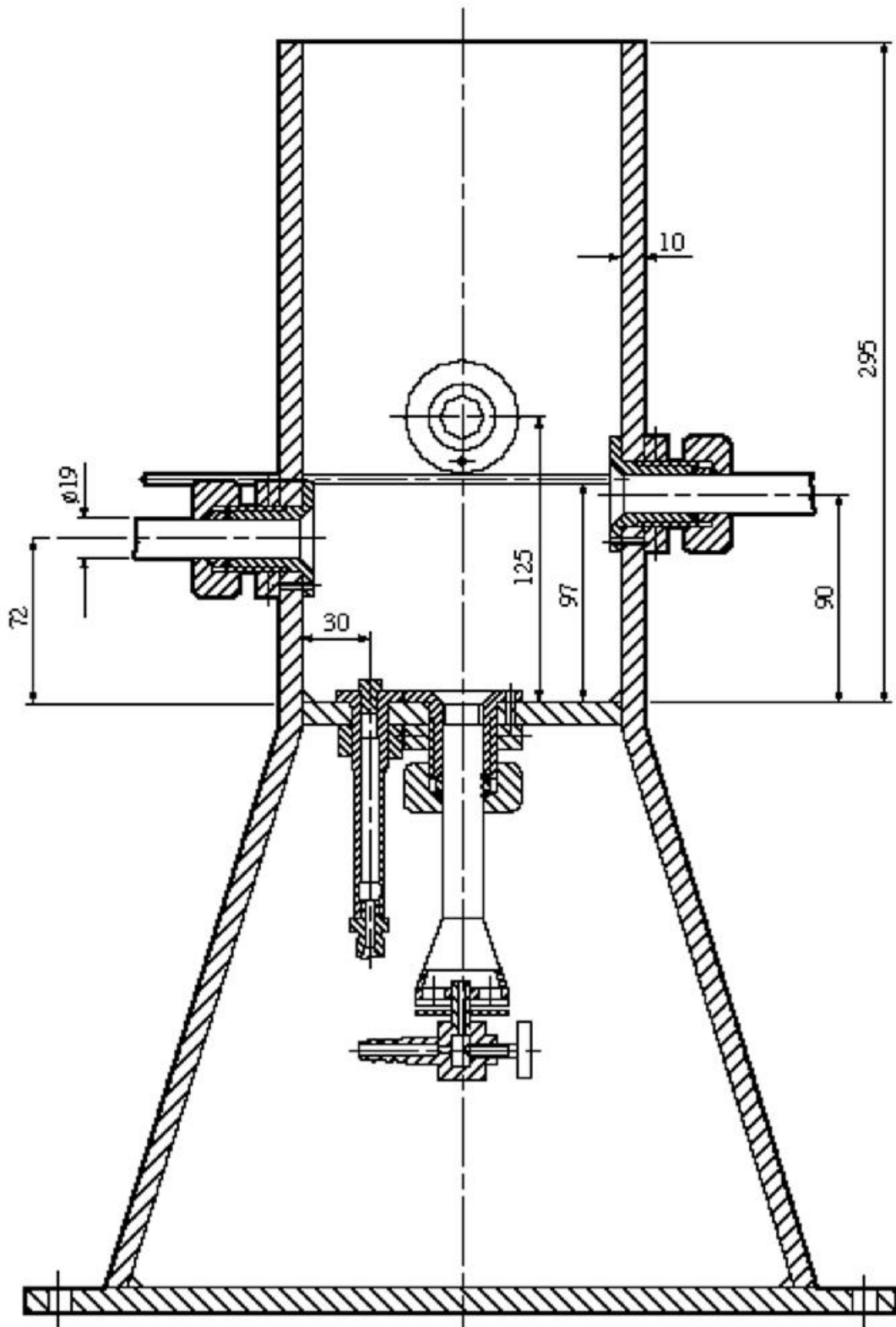

Figure 18.4.3.1.2: HEATING AND PROTECTIVE DEVICE

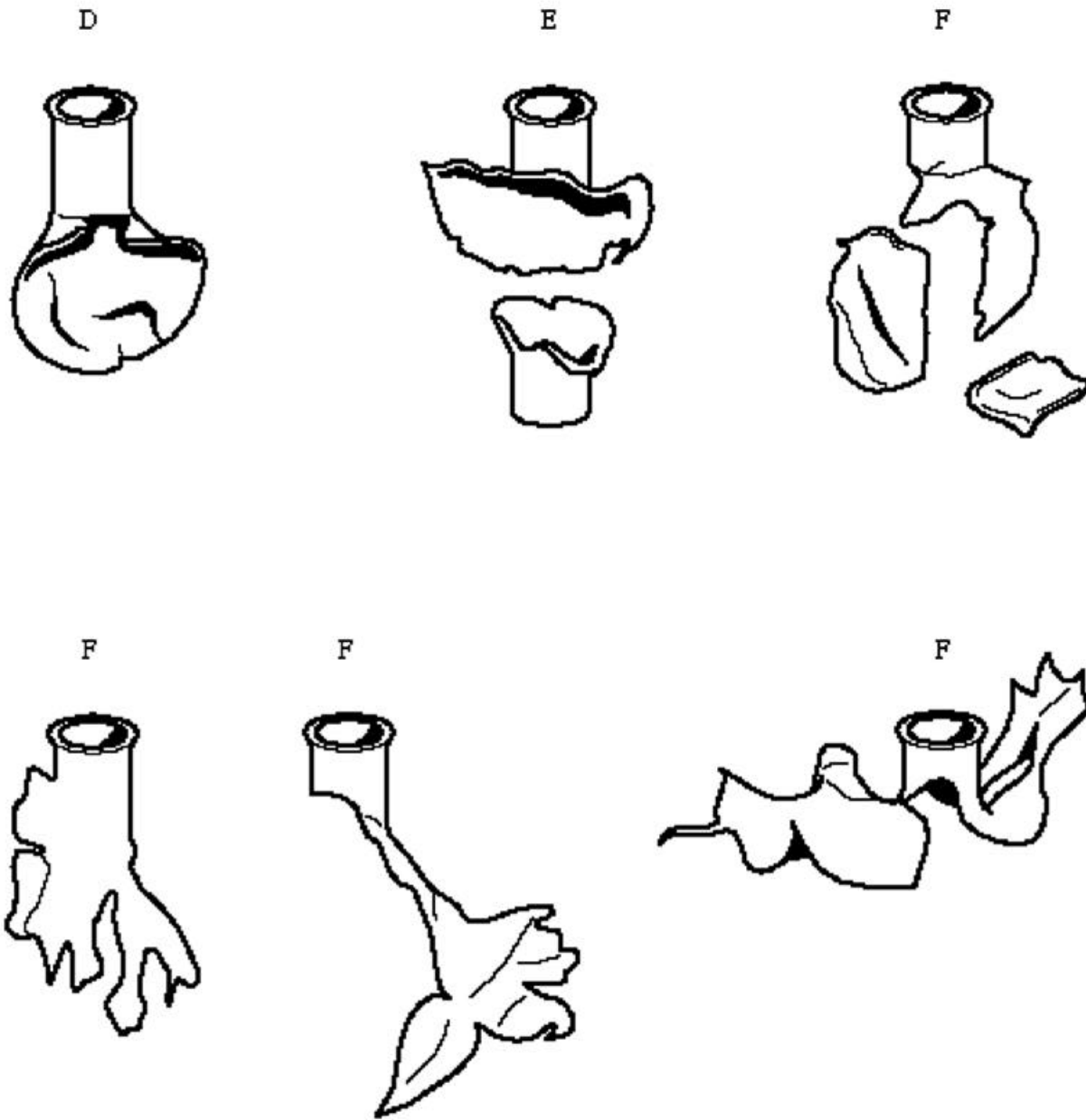

Figure 18.4.3.1.3 EXAMPLES OF EFFECT TYPES D, E AND F

18.4.4 *Test 8 (d): Modified USA DDT test*

18.4.4.1 *Introduction*

This test is used to determine the tendency of a candidate ammonium nitrate emulsion, intermediate for blasting explosive to undergo transition from deflagration to detonation.

18.4.4.2 *Apparatus and materials*

The experimental arrangement is shown in figure 18.4.4.1.1. The substance to be tested is contained in a 457 mm length of "3 inch schedule 80" carbon (A53 Grade B) steel pipe with inside diameter 74 mm, wall thickness 7.6 mm, capped at one end with a "3000 pound" forged steel pipe cap, and at the other with a 13 cm square, 8 mm thick mild steel witness plate which is welded to the pipe. An igniter consisting of 20 g of black powder (100% passed through No. 20 sieve, 0.84 mm, and 100% retained by No. 50 sieve, 0.297 mm) is located at the centre of the sample vessel. The igniter assembly consists of a cylindrical container 21 mm in diameter and 64 mm which is made from 0.54 mm thick cellulose acetate which is held together by two layers of nylon filament reinforced cellulose acetate tape. The igniter capsule contains a small loop formed from a 25 mm length of nickel-chromium alloy resistance wire 0.30 mm in diameter having a resistance of 0.343 ohms. This loop is attached to two insulated copper lead wires. These lead wires are fed through small holes in the wall of the pipe and are sealed with epoxy resin.

18.4.4.3 *Procedure*

After the sample is loaded into the pipe to a height of 23 cm, the igniter (with its leads inserted through small holes in the pipe wall) is inserted into the centre of the pipe and the leads pulled taut and sealed with epoxy resin. The remainder of the sample is then loaded, and the top cap screwed on. The tube is placed in a vertical position and the igniter is fired by a current of 15 amperes obtained from a 20-volt transformer. Three trials should be performed unless deflagration to detonation transition occurs earlier.

18.4.4.4 *Test criteria and method of assessing results*

The test result is considered "+" and the substance should not be classified in Division 5.1 if a hole is punched through the witness plate. If no hole is punched through the witness plate then the result is considered "—".

18.4.4.5 *Examples of results*

Substance	Apparent density (kg/m ³)	Result
to be added		

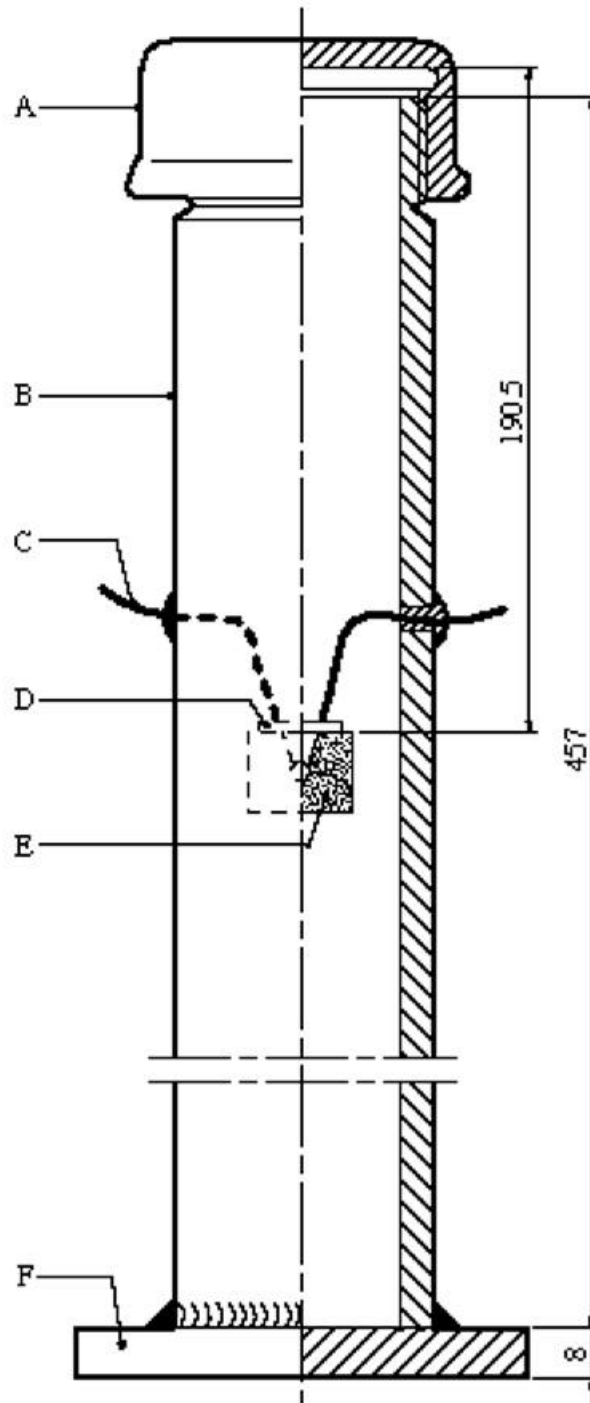

(A)	Forged steelcap	(B)	Steel pipe
(C)	Igniter leads	(D)	Seal
(E)	Igniter assembly	(F)	Witness plate

18.4.5 **Figure 18.4.4.2.1: MODIFIED USA DDT TEST**
Test 8 (e): USA vented pipe test

18.4.5.1 *Introduction*

The vented pipe test is used to assess the effect of exposure of a candidate ammonium nitrate emulsion, intermediate for blasting explosives to a large fire under confined, vented conditions.

18.4.5.2 *Apparatus and materials*

The following items are needed:

- (a) A steel pipe (*specification to be provided by USA*) 30 ± 1 cm diameter and 60 ± 1 cm long, welded close at the bottom with a 38 cm square, 10 ± 0.5 mm thick mild steel plate. The top of the pipe is welded to a 38 cm square, 10 ± 0.5 mm thick mild steel plate that contains a 76 mm diameter vent hole centrally located in the plate to which a 150 mm long steel pipe nipple of 76 mm internal diameter is welded. (See figure 18.4.5.1.1) (*Further specifications on inner/outer diameter, wall thickness and tolerances to be provided*)
- (b) A metal grid strong enough to support the filled pipe above the fuel and allow adequate heating.
- (c) Enough fuel to keep a fire burning for at least 30 minutes or, if necessary, until the substance has clearly had enough time to react to the fire.
- (d) Suitable means of ignition, e.g. fuel oil and pyrotechnic igniter with wood wool.

Video or movie cameras may be used.

18.4.5.3 *Procedure*

18.4.5.3.1 The pipe is filled with the substance under test without tamping during loading. The substance is carefully packed to prevent adding voids. The steel pipe is placed vertically on the grid. Fuel is placed beneath the grid so that the fire will engulf the pipe. Precautions against side winds may be required to avoid dissipation of the heat. Suitable methods of heating include a wood fire using a lattice of wooden laths, liquid or a gas fuel fire, that produces a flame temperature of at least 800°C . ***The fire shall be started from a safe place. If the pipe does not rupture, the system should be allowed to cool down before carefully dismantling the test set-up and emptying the pipe.***

18.4.5.3.2 Observations are made on the following:

- (a) evidence of explosion;
- (b) loud noise; and
- (c) projection of fragments from the fire area.

18.4.5.4 *Test criteria and method of assessing results*

The test result is considered "+" and the substance should not be classified in Division 5.1 if an explosion or a rupture of the pipe is observed. If no explosion or rupture of the pipe is observed then the result is considered "—".

18.4.5.5 *Examples of results*

Substance

Result

to be added

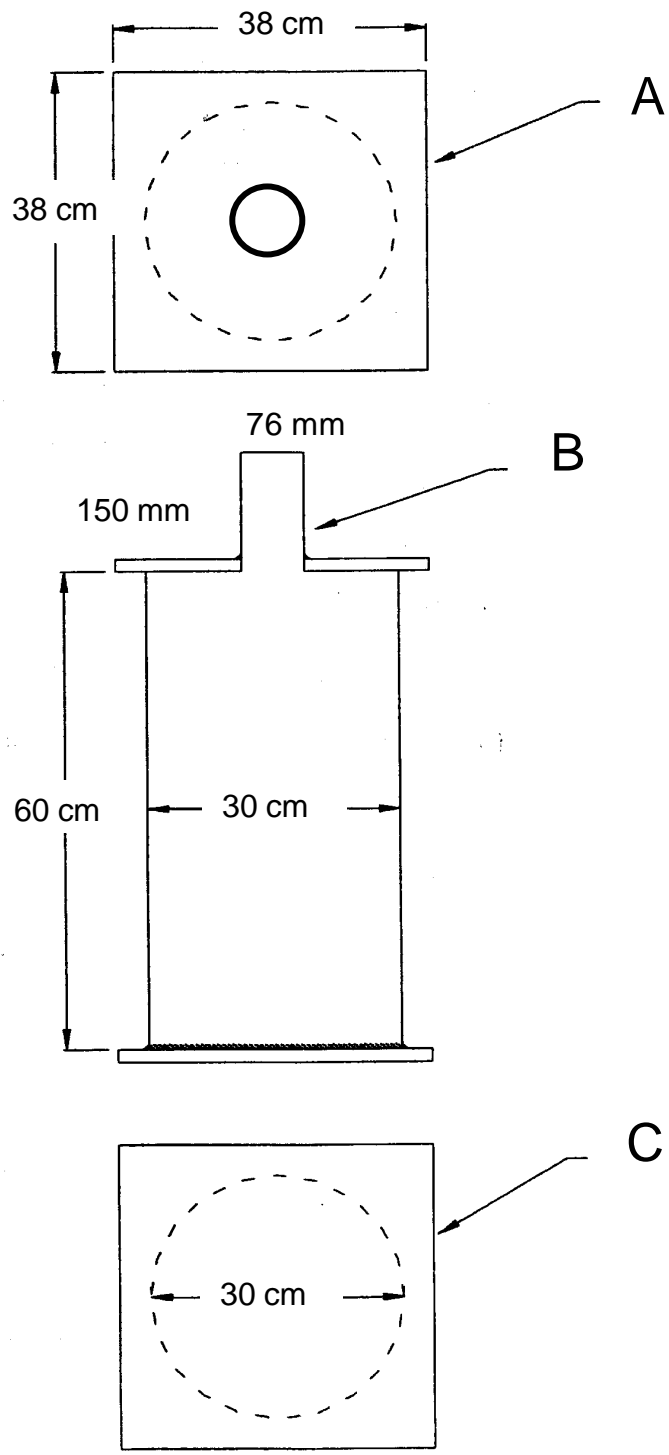

- (A) Top plate
- (B) Steel pipe nipple
- (C) Bottom plate

Figure 18.4.5.1: VENTED PIPE TEST
