



Economic and Social Council

Distr.: General
28 July 2014

Original: English

Economic Commission for Europe

Inland Transport Committee

Working Party on Customs Questions affecting Transport

138th session

Geneva, 7–10 October 2014

Item 4 (b) (ii) of the provisional agenda

Customs Convention on the International Transport of Goods under Cover of TIR Carnets (TIR Convention, 1975):

Revision of the Convention –

Amendment proposals to the Convention: Vehicles with sliding sheets

Vehicles and containers with sliding sheets

Submitted by the International Association of the Body and Trailer Building Industry

I. Introduction

1. At its 131st, 132nd, 133rd, 134rd, 136th and 137th sessions, the Working Party on Customs questions affecting Transport (WP.30) considered document ECE/TRANS/WP.30/2012/6 and its revisions submitted by the International Association of the Body and Trailer Building Industry (CLCCR), containing amendment proposals in order to add to the TIR Convention a new design of a vehicle and container. WP.30 found its construction to be generally Customs secure and agreed that this new design of vehicles and containers with sliding roof could be incorporated into Annexes 2 and 7 of the Convention.

2. During its 137th session WP.30 considered a revised document ECE/TRANS/WP.30/2012/6/Rev.5 jointly elaborated by Belarus, Germany, CLCCR and the secretariat. WP.30 decided that one drawing of sketch No 10.3, showing a patented system, should be deleted from the draft amendment proposals and that for legal reasons the images contained therein needed to be replaced by sketches. WP.30 requested the secretariat to prepare a final revision of document ECE/TRANS/WP.30/2012/6/Rev.5 for consideration at its next session, in order to be able to establish if these amendment proposals could be submitted to AC.2 for adoption (see ECE/TRANS/WP.30/274, para. 20).

GE.14-09687 (E)



* 1 4 0 9 6 8 7 *

Please recycle The recycling symbol, consisting of three chasing arrows forming a triangle.



3. The present document has been prepared by CLCCR and the secretariat in line with the request of the Working Party. The proposed modifications to the current text of the Convention are marked in bold and strikethrough.

II. Amendment proposals

4. For Annex 2, Article 4, paragraph 2, point (i) *read*

"(i) The sliding sheets, floor, doors and all other constituent parts of the load compartment shall be assembled ~~in such a way that they cannot be opened or closed~~ **either by means of devices which cannot be removed and replaced from the outside** without leaving obvious traces, **or by such methods as will produce a structure which cannot be modified without leaving obvious traces**".

5. For Annex 2, Article 4, paragraph 2, point (iii) *read*

"(iii) The sliding sheet guidance, **sliding sheet tension devices** and other movable parts shall be assembled in such a way that **when** closed, and Customs sealed, doors and other movable parts cannot be opened or closed from the outside without leaving obvious traces. The sliding sheet guidance, **sliding sheet tension devices** and other movable parts shall be assembled in such a way that it is impossible to gain access to the load compartment without leaving obvious traces **once the closing devices have been secured. An example of such a system of construction is given in sketch No. 9 appended to these Regulations.**"

6. Annex 2, after Article 4 insert a new Article 5 to *read*

"Article 5

Vehicles with a sheeted sliding roof

1. Where applicable, the provisions of Articles 1, 2, 3 and 4 of these Regulations shall apply to vehicles with a sheeted sliding roof. In addition, these vehicles shall conform to the provisions of this Article.

2. The sheeted sliding roof shall fulfil requirements set out in (i) to (iii) below.

- (i) The sheeted sliding roof shall be assembled either by means of devices which cannot be removed and replaced from the outside without leaving obvious traces, or by such methods as will produce a structure which cannot be modified without leaving obvious traces.
- (ii) The sliding roof sheet shall overlap with the solid part of the roof at the front side of the load compartment, so that the roof sheet cannot be pulled over the top edge of the upper cantrail. In the length of the load compartment, at both sides, in the hem of the roof sheet, a pre-stressed steel cable shall be inserted in such a way that it cannot be removed and re-inserted without leaving obvious traces. The roof sheet shall be secured to the sliding carriage in such a way that it cannot be removed and re-secured without leaving obvious traces.
- (iii) The sliding roof guidance, the sliding roof tension devices and other movable parts shall be assembled in such a way that when closed, and Customs sealed, doors, roof and other movable parts cannot be opened or closed from the outside without leaving obvious traces. The sliding

roof guidance, sliding roof tension devices and other movable parts shall be assembled in such a way that it is impossible to gain access to the load compartment without leaving obvious traces once the closing devices have been secured.

An example of a possible system of construction is shown in sketch No.10, appended to these Regulations.

7. For the existing sketch No. 9 substitute

Sketch No. 9

EXAMPLE OF A CONSTRUCTION OF A VEHICLE WITH SLIDING SHEETS

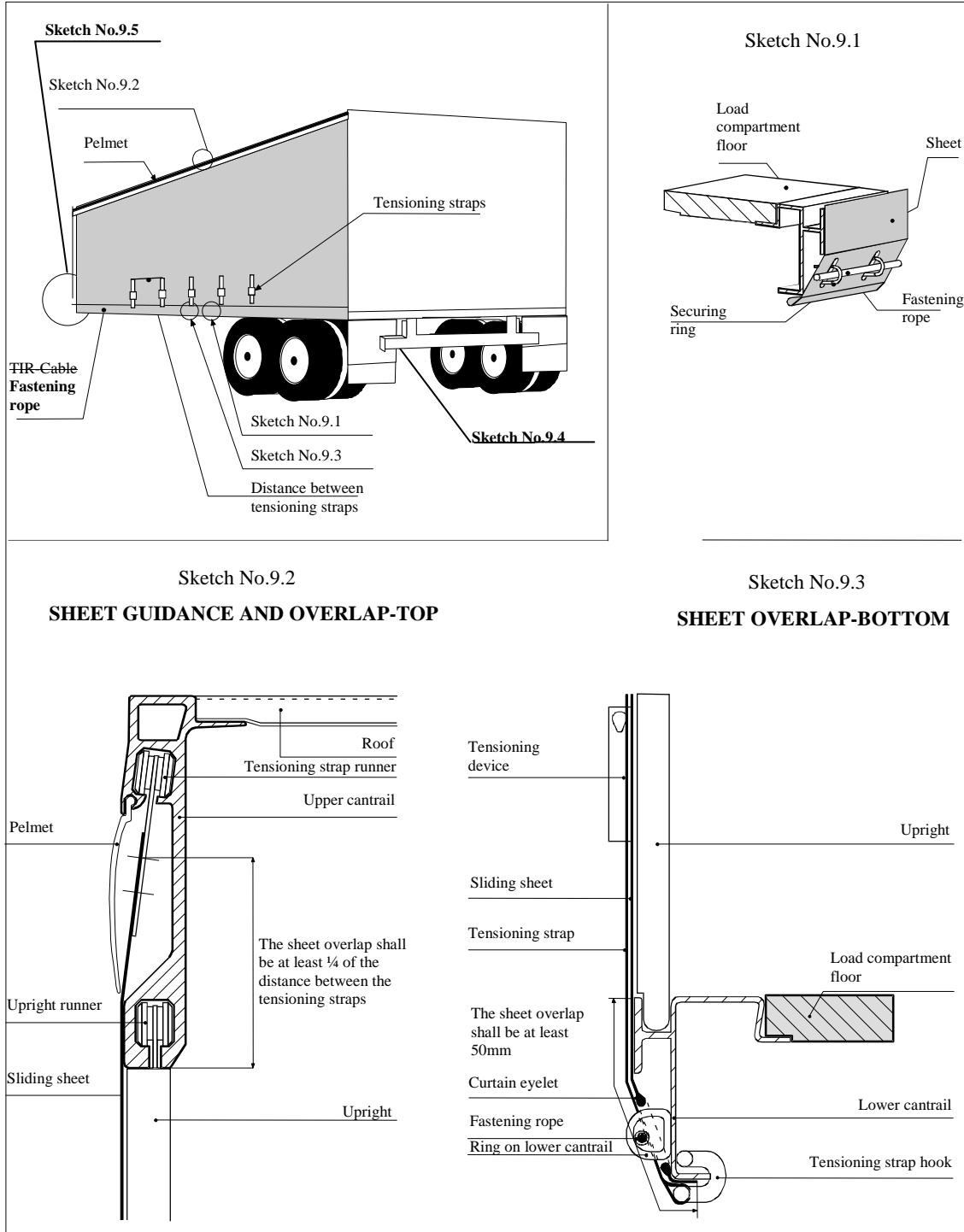

Sketch No.9 continued

Sketch No. 9.4

To tighten the sliding sheets in the horizontal direction, a ratchet gear is used (normally at the rear end of the vehicle). This sketch shows two examples, (a) and (b), of how the ratchet or gearbox may be secured.

(a) Ratchet securing

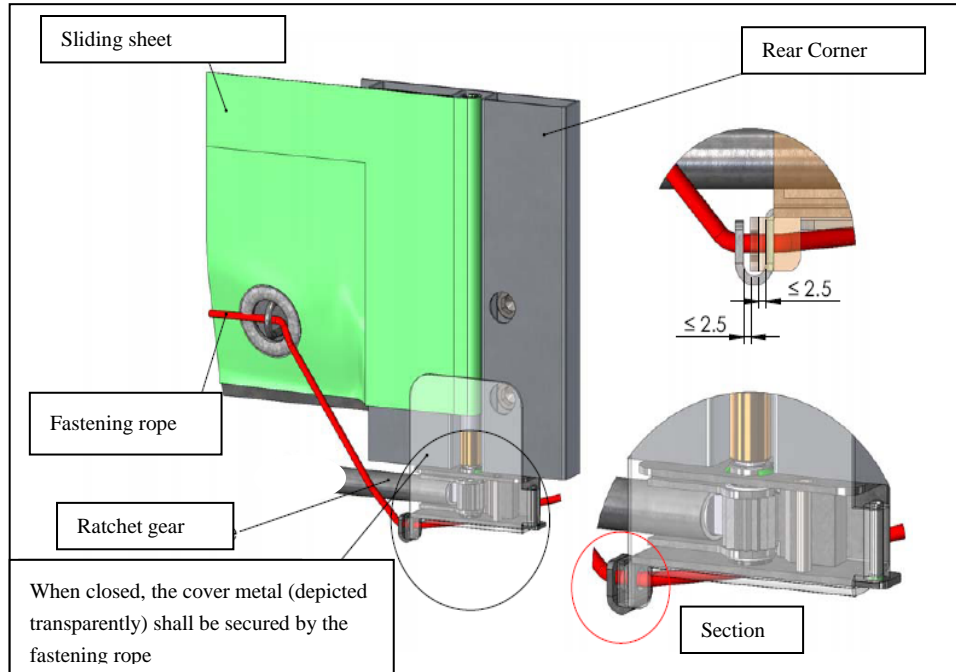

(b) Gearbox securing

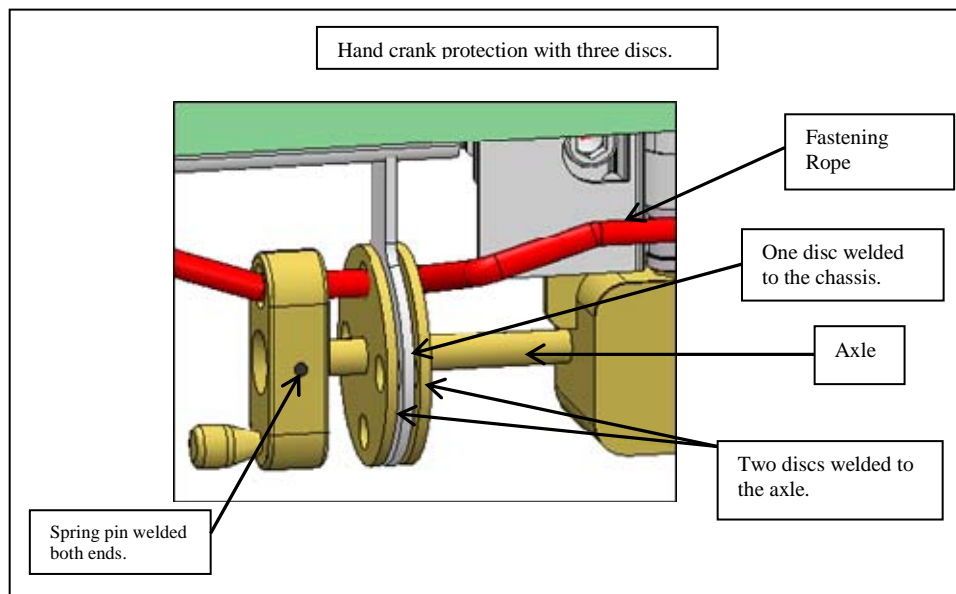

Sketch No. 9 continued

Sketch No. 9.5

To fix the sliding sheet on the other side (normally the front of the vehicle), the following systems, (a) or (b), may be used.

(a) Cover metal

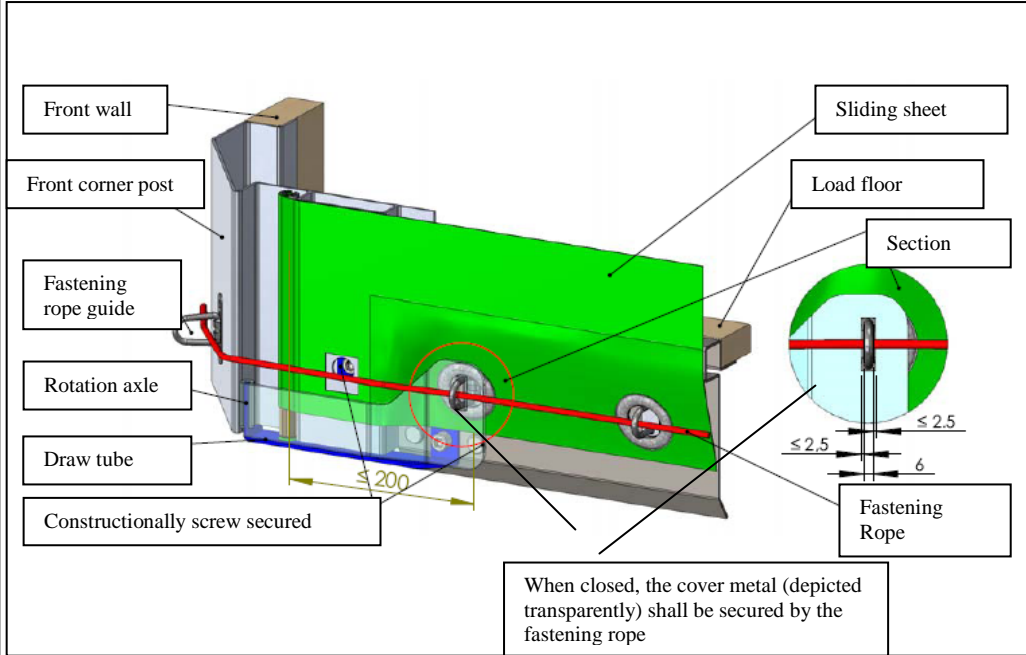

(b) Narrow oval eyelet, anti-lifting system for the tensioning tube

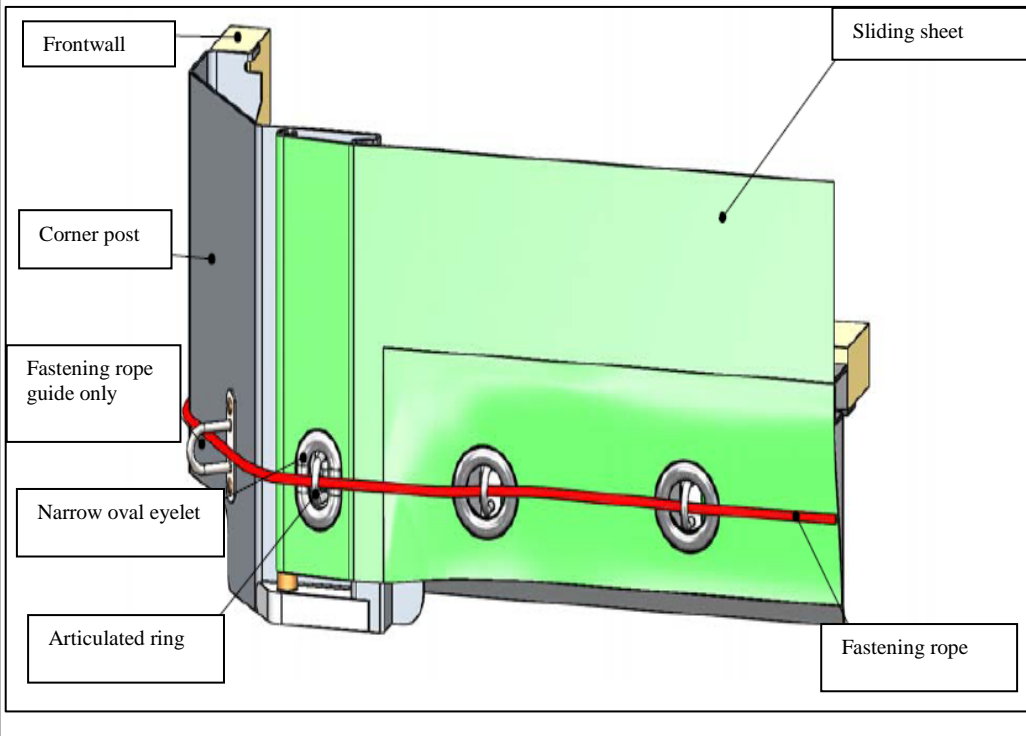

8. Add the following new sketch to the existing sketches appended to Annex 2

Sketch No. 10

EXAMPLE OF A CONSTRUCTION OF A VEHICLE WITH A SHEETED SLIDING ROOF

This sketch shows an example of a vehicle and the important requirements described in Article 5 of these Regulations.

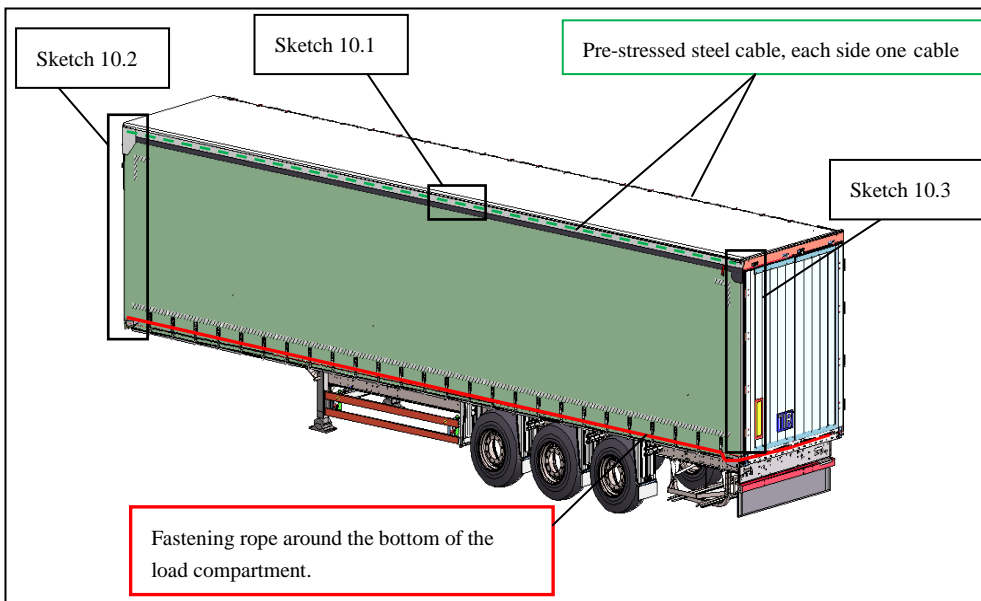

Sketch No. 10.1

Two pre-stressed steel cables, embedded in a hem, are fixed on each side of the load compartment. This pre-stressed steel cable is fixed to the front (see sketch 10.2) and rear of the body (see sketch 10.3). The tractive force as well as the connecting disc on each sliding carriage makes it impossible to lift up the hem with the pre-stressed steel cable above the upper cantrail.

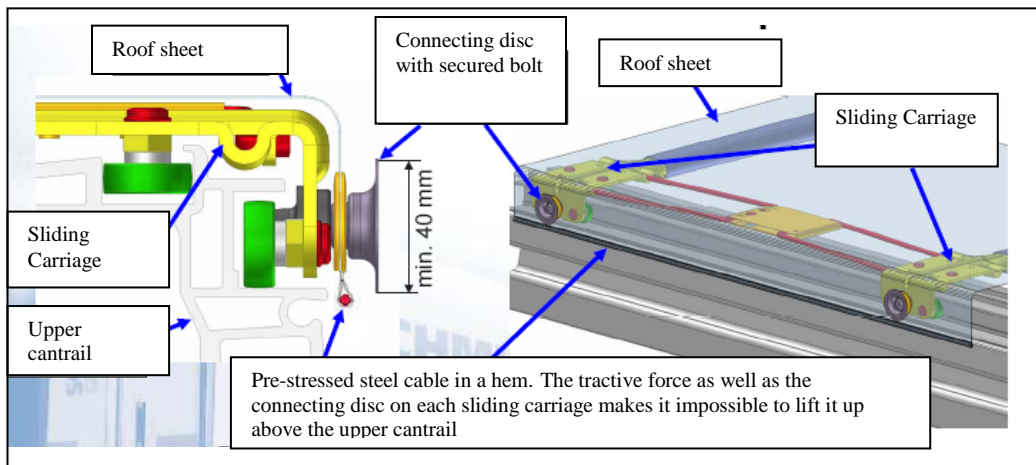

Sketch No. 10 continued

Sketch No.10.2

The sliding roof sheet shall overlap with the solid part of the roof at the front side of the load compartment, so that the roof sheet cannot be pulled over the top edge of the upper cantrail.

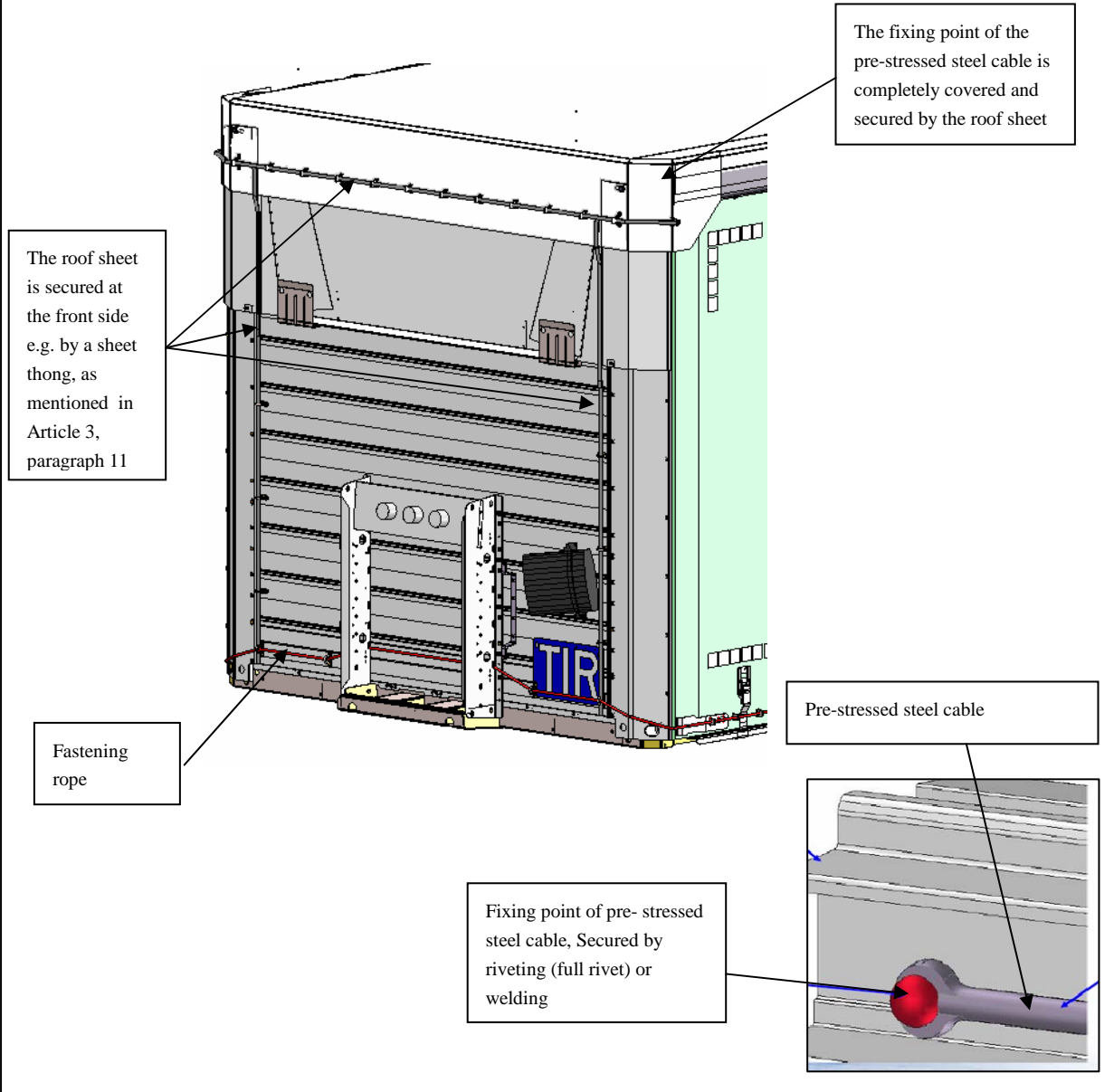

Sketch No. 10 continued

Sketch No.10.3

At the rear, a special device, such as a baffle plate, is fitted to the roof, preventing access to the load compartment, without leaving obvious traces when the doors are closed and sealed.

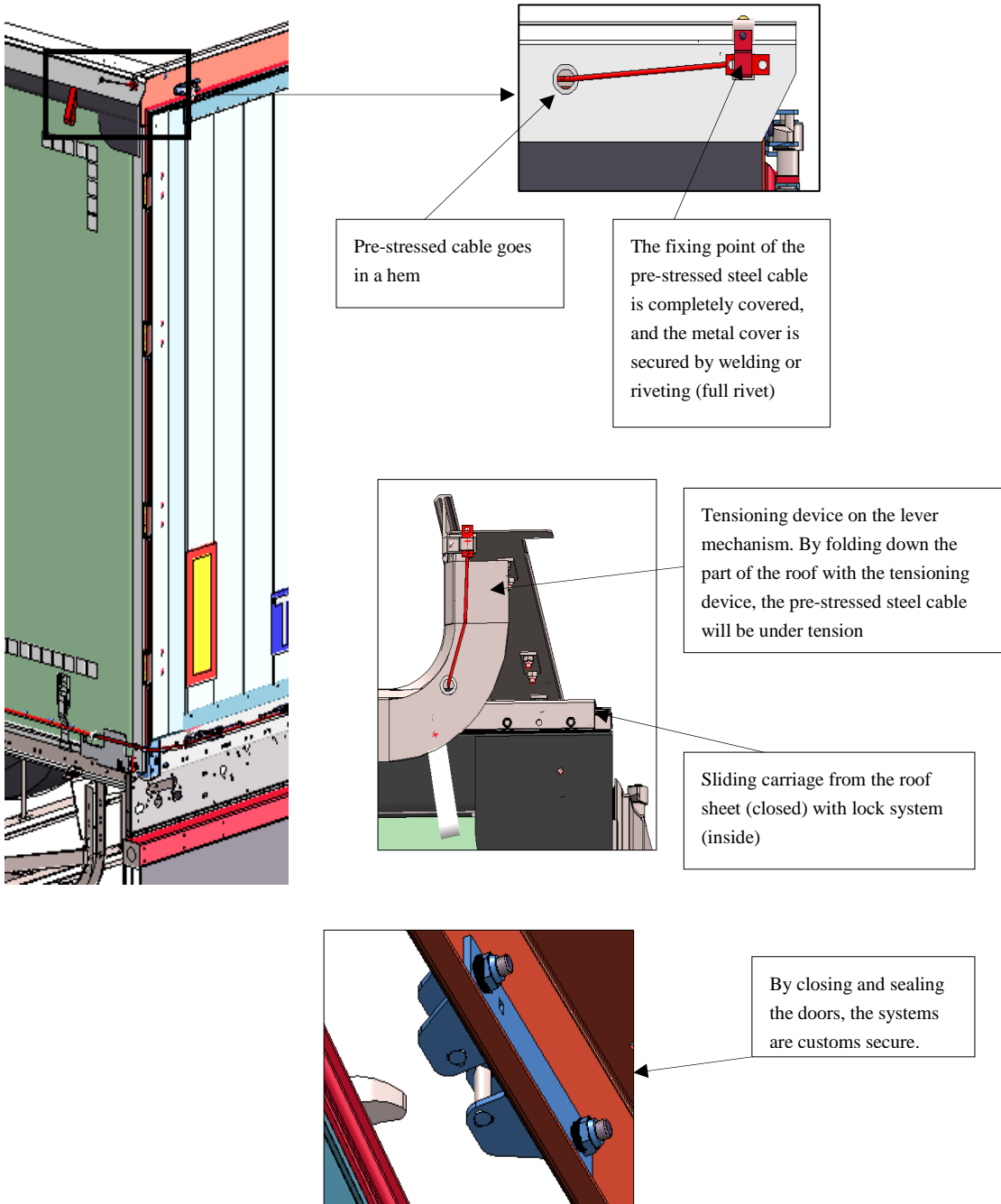

9. For Annex 7, Part I, Article 5, paragraph 2, point (i) read

"(i) The sliding sheets, floor, doors and all other constituent parts of the container shall be assembled ~~in such a way that they cannot be opened or closed~~ **either by means of devices which cannot be removed and replaced from the outside** without leaving obvious traces, **or by such methods as will produce a structure which cannot be modified without leaving obvious traces**".

10. For Annex 7, Part I, Article 5, paragraph 2, point (iii) read

"(iii) The sliding sheet guidance, **sliding sheet tension devices** and other movable parts shall be assembled in such a way that **when** closed, and Customs sealed, doors and other movable parts cannot be opened or closed from the outside without leaving obvious traces. The sliding sheet guidance, **sliding sheet tension devices** and other movable parts shall be assembled in such a way that it is impossible to gain access to the container without leaving obvious traces **once the closing devices has been secured**. ~~The system is described in~~ **An example of such a system of construction is given in sketch No. 9 appended to these Regulations.**"

11. Annex 7, Part I, after Article 5 insert a new Article 6 to read

"Article 6

Containers with a sheeted sliding roof

1. Where applicable, the provisions of Articles 1, 2, 3, 4 and 5 of these Regulations shall apply to containers with a sheeted sliding roof. In addition, these containers shall conform to the provisions of this Article.

2. The sheeted sliding roof shall fulfil the requirements set out in (i) to (iii) below.

- (i) The sheeted sliding roof shall be assembled either by means of devices which cannot be removed and replaced from the outside without leaving obvious traces, or by such methods as will produce a structure which cannot be modified without leaving obvious traces.
- (ii) The sliding roof sheet shall overlap with the solid part of the roof at the front side of the container, so that the roof sheet cannot be pulled over the top edge of the upper cantrail. In the length of the container, at both sides, in the hem of the roof sheet, a pre-stressed steel cable shall be inserted in such a way that it cannot be removed and re-inserted without leaving obvious traces. The roof sheet shall be secured to the sliding carriage in such a way that it cannot be removed and re-secured without leaving obvious traces.
- (iii) The sliding roof guidance, the sliding roof tension devices and other movable parts shall be assembled in such a way that when closed, and Customs sealed, doors, roof and other movable parts cannot be opened or closed from the outside without leaving obvious traces. The sliding roof guidance, sliding roof tension devices and other movable parts shall be assembled in such a way that it is impossible to gain access to the container without leaving obvious traces once the closing devices have been secured.

An example of a possible system of construction is shown in sketch No. 10, appended to these Regulations."

12. For the existing sketch No. 9 substitute

Sketch No. 9

EXAMPLE OF A CONSTRUCTION OF A CONTAINER WITH SLIDING SHEETS

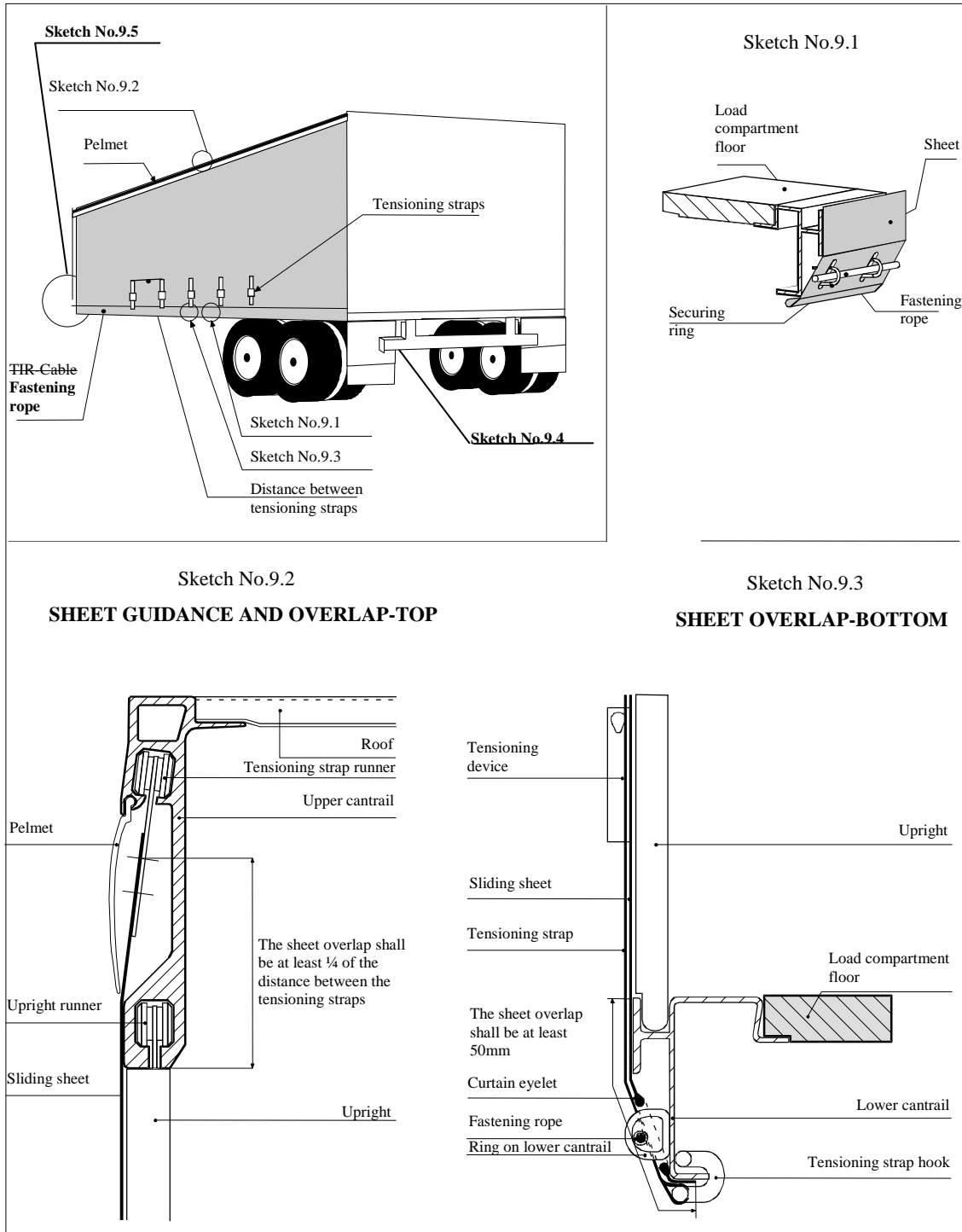

Sketch No.9 continued

Sketch No. 9.4

To tighten the sliding sheets in the horizontal direction, a ratchet gear is used (normally at the rear end of the container). This sketch shows two examples, (a) and (b), of how the ratchet or gearbox may be secured.

(a) Ratchet securing

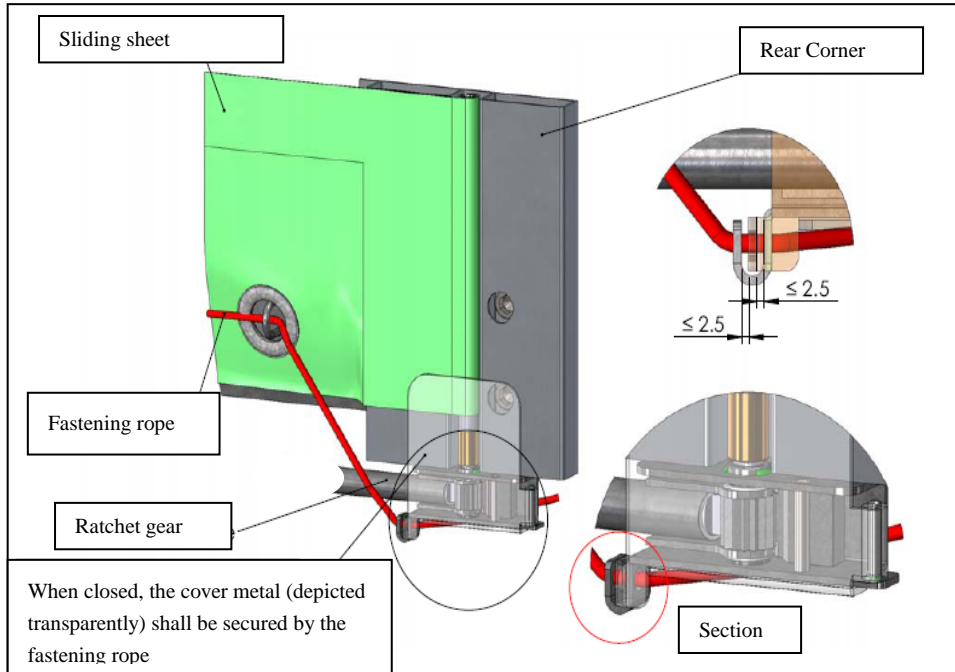

(b) Gearbox securing

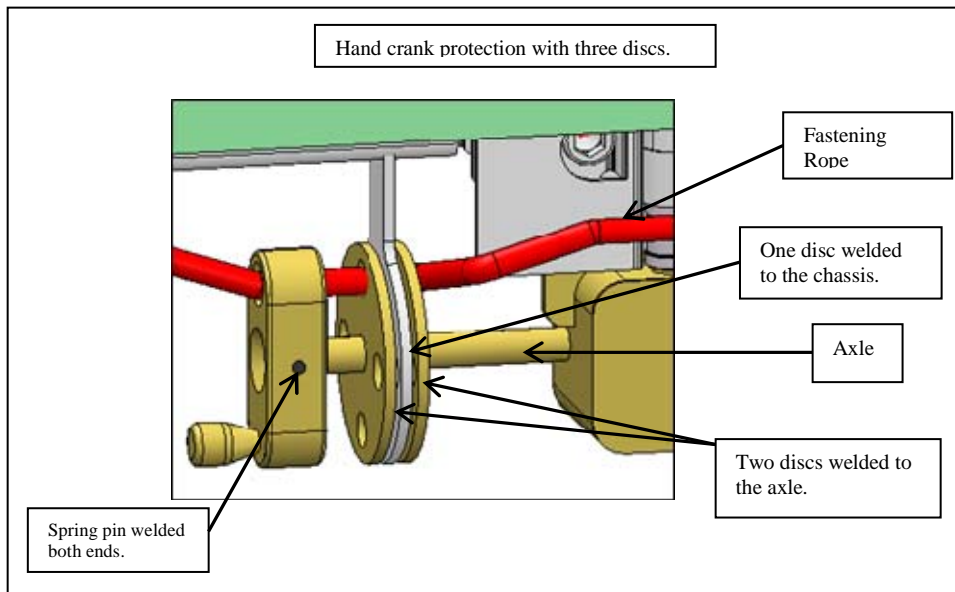

Sketch No. 9 continued

Sketch No. 9.5

To fix the sliding sheet on the other side (normally the front of the container), the following systems, (a) or (b), may be used.

(a) Cover metal

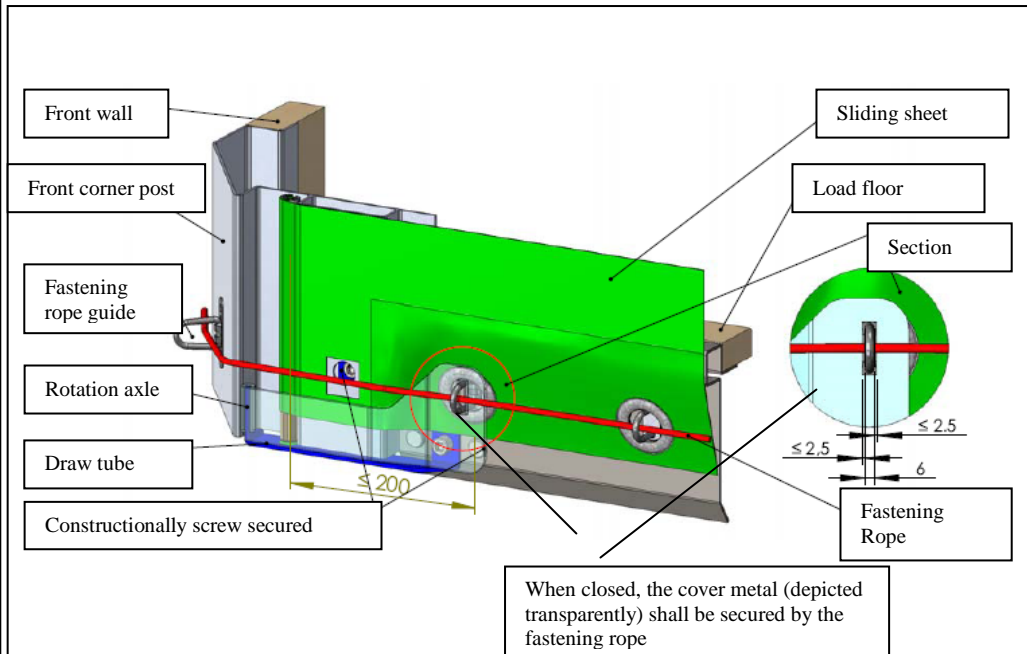

(b) Narrow oval eyelet, anti-lifting system for the tensioning tube

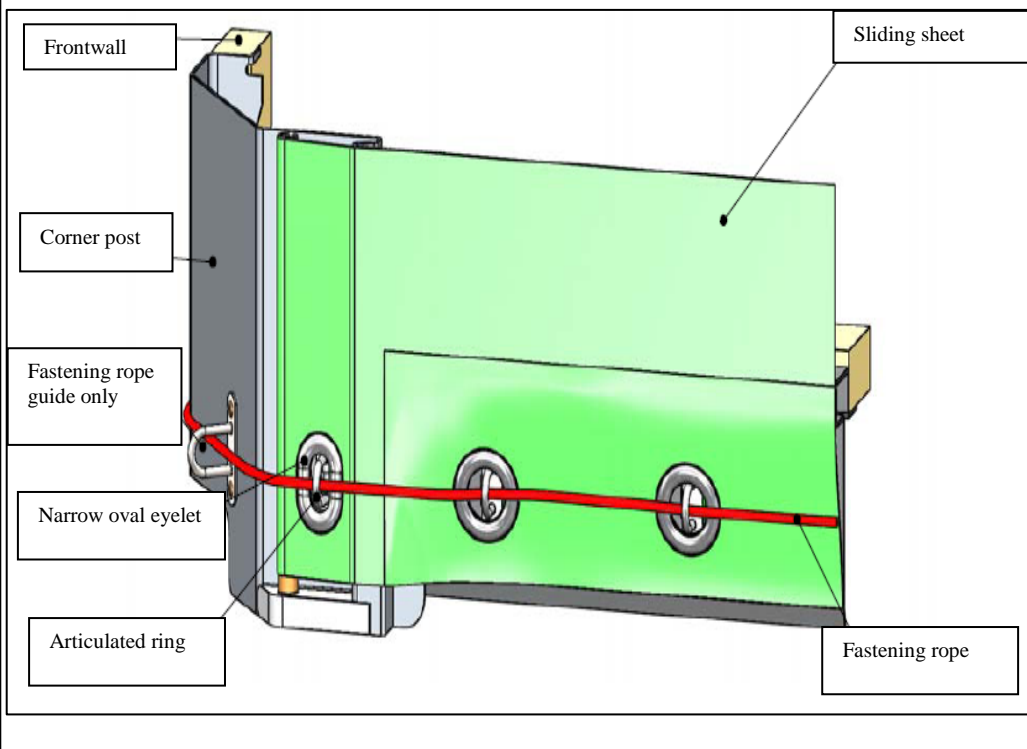

13. Add the following new sketch to the existing sketches appended to Annex 2

Sketch No. 10

EXAMPLE OF A CONSTRUCTION OF A CONTAINER WITH A SHEETED SLIDING ROOF

This sketch shows an example of a container and the important requirements described in Article 6 of these Regulations.

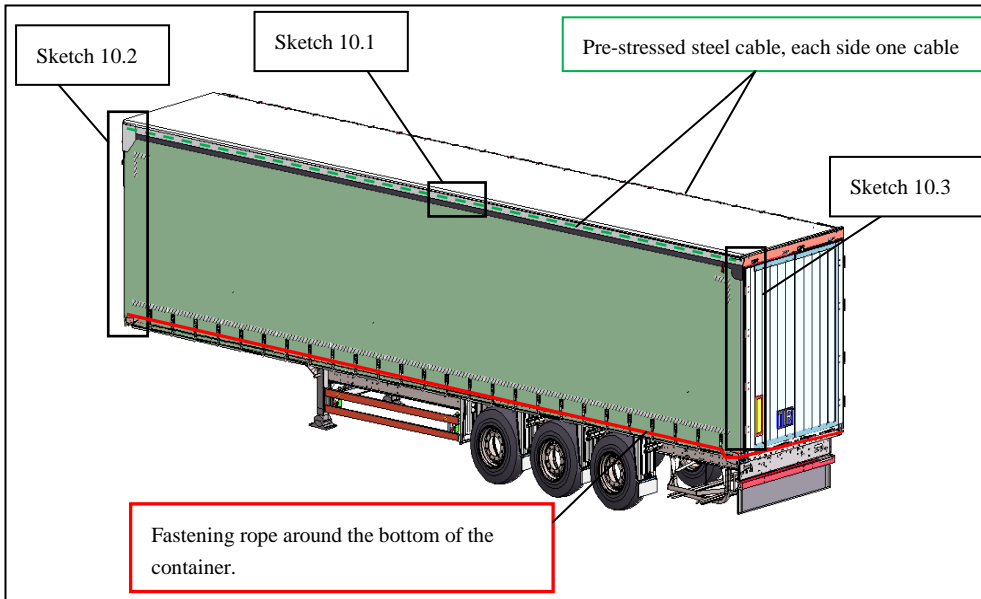

Sketch No. 10.1

Two pre-stressed steel cables, embedded in a hem, are fixed on each side of the container. This pre-stressed steel cable is fixed to the front (see sketch 10.2) and rear (see sketch 10.3). The tractive force as well as the connecting disc on each sliding carriage makes it impossible to lift up the hem with the pre-stressed steel cable above the upper cantrail.

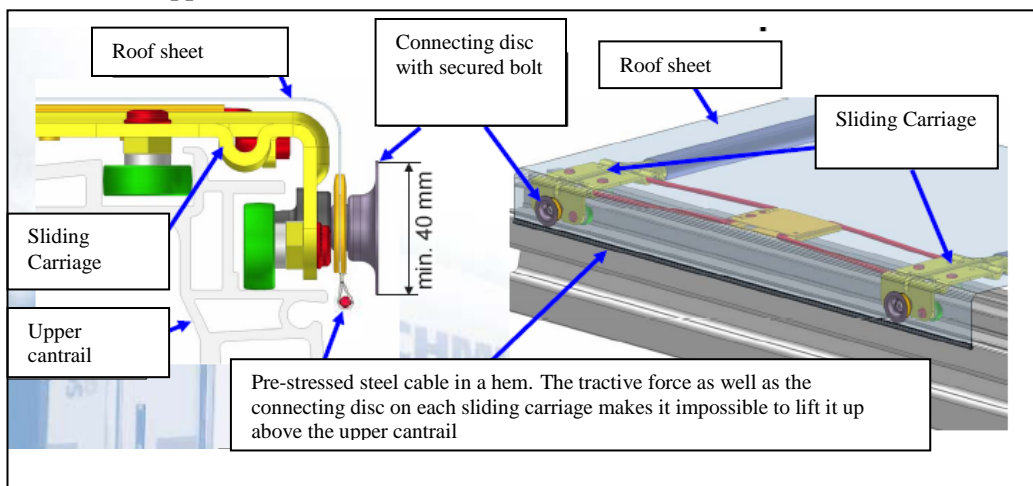

Sketch No. 10 continued

Sketch No.10.2

The sliding roof sheet shall overlap with the solid part of the roof at the front side of the container, so that the roof sheet cannot be pulled over the top edge of the upper cantrail

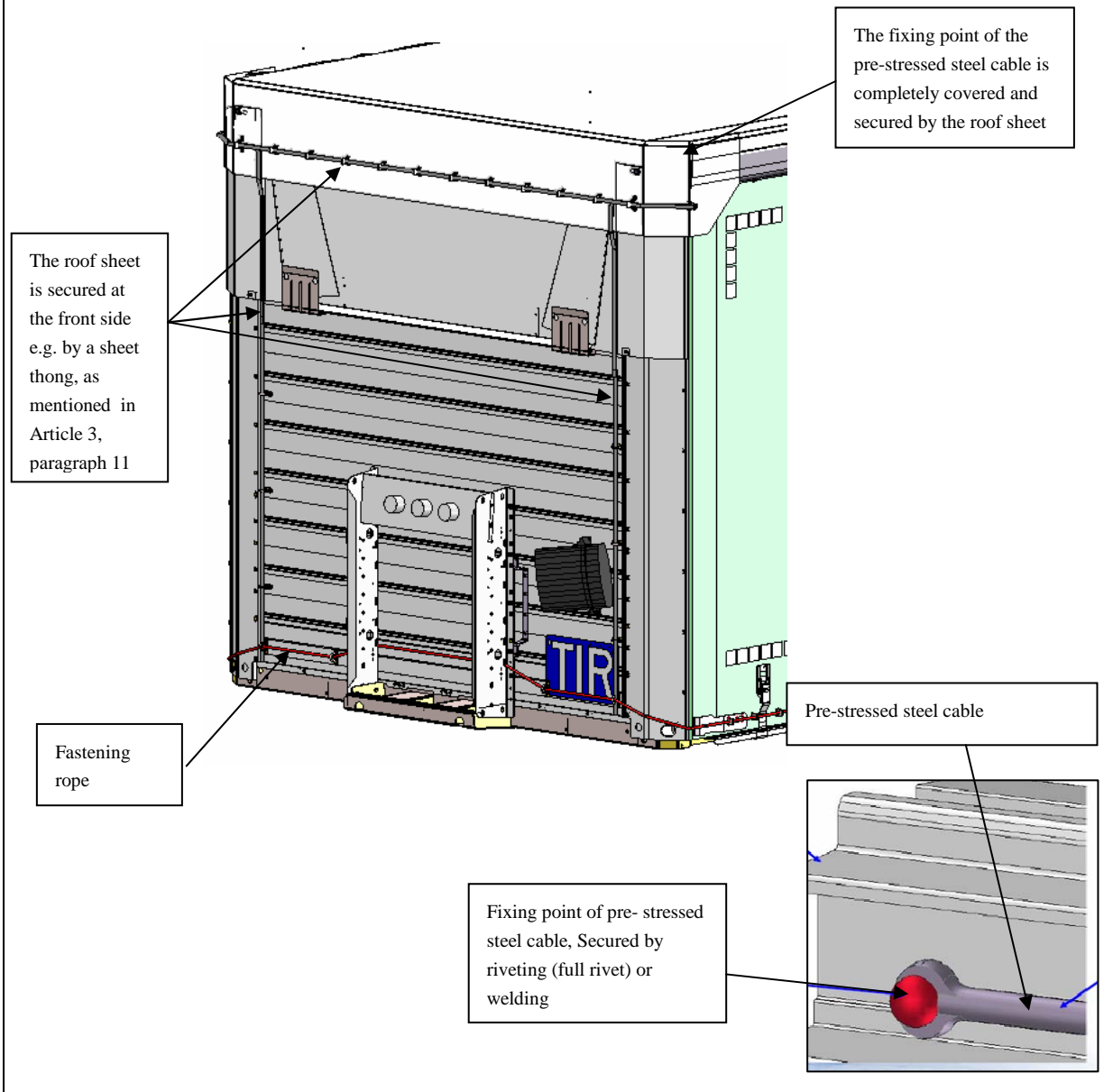

Sketch No. 10 continued

Sketch No.10.3

At the rear, a special device, such as a baffle plate, is fitted to the roof, preventing access to the container, without leaving obvious traces when the doors are closed and sealed.

