



**Economic and Social
Council**

Distr.
GENERAL

ECE/TRANS/WP.30/2006/16
4 August 2006

Original: ENGLISH

ECONOMIC COMMISSION FOR EUROPE

INLAND TRANSPORT COMMITTEE

Working Party on Customs Questions Affecting Transport

One-hundred-and-fourteenth session
Geneva, 26-29 September 2006
Item 9 (c) (iii) of the provisional agenda

**CUSTOMS CONVENTION ON THE INTERNATIONAL TRANSPORT OF GOODS UNDER
COVER OF TIR CARNETS (TIR CONVENTION, 1975)**

Application of the Convention

Issues relating to technical provisions *

Transmitted by the European Union Customs Assistance Program in Serbia and Montenegro
(CAFAO) **

1. The secretariat reproduces in the annex a manual prepared by the European Union Customs Assistance Program in Serbia and Montenegro (CAFAO) containing an example of a best practice concerning the approval and control procedures to be applied for vehicles and loading units being used under the TIR procedure.
2. It is the aim and hope of the secretariat that this manual will assist Contracting Parties in implementing correctly the provisions of the TIR Convention concerning approval and control of vehicles and loading units in accordance to Annexes 2 and 7 of the Convention.

* The UNECE Transport Division has submitted the present document after the official documentation deadline.

** The secretariat reproduces the document as received in 2005.

Annex

Sealing of Vehicles

SECURITY and RISKS

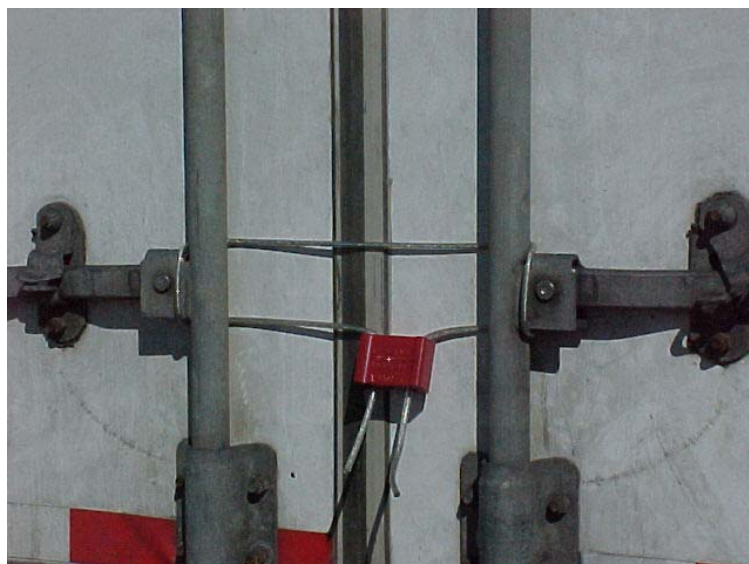

Good Practice Guide



CAFAO SERBIA - MONTENEGRO

Enforcement Project

Belgrade, 2005



Introduction

For more than a century Customs and Fiscal Authorities have used different methods of sealing in order to protect revenue, combat fraud and prevent smuggling, but indeed also to facilitate trade and transport.

Today the Customs seal is most frequently used for sealing vehicles of all sorts carrying out international transport, and it is obvious that such vehicles must meet specific international requirements in terms of technical standard and security – and that such requirements are updated regularly.

World wide recognized standards and specifications can – at the moment – only be found in the TIR Convention, and this manual is based on the technical specifications and requirements as outlined in this Convention.

This manual has been prepared as a guide to MCA staff employed at the Border Crossing Points and Customs Stations – and also staff responsible for the approval of vehicles under the TIR Convention.

Although potential risks in terms of security have been identified and described, this manual is not exhaustive, as new technical details and vehicles are constantly produced, approved and introduced within international trade and transport.

ECONOMIC COMMISSION FOR EUROPE
(UNECE)

TIR HANDBOOK



**CUSTOMS CONVENTION ON THE INTERNATIONAL TRANSPORT OF
GOODS
UNDER COVER OF TIR CARNETS
(TIR CONVENTION, 1975)**



UNITED NATIONS
New York and Geneva, 2002

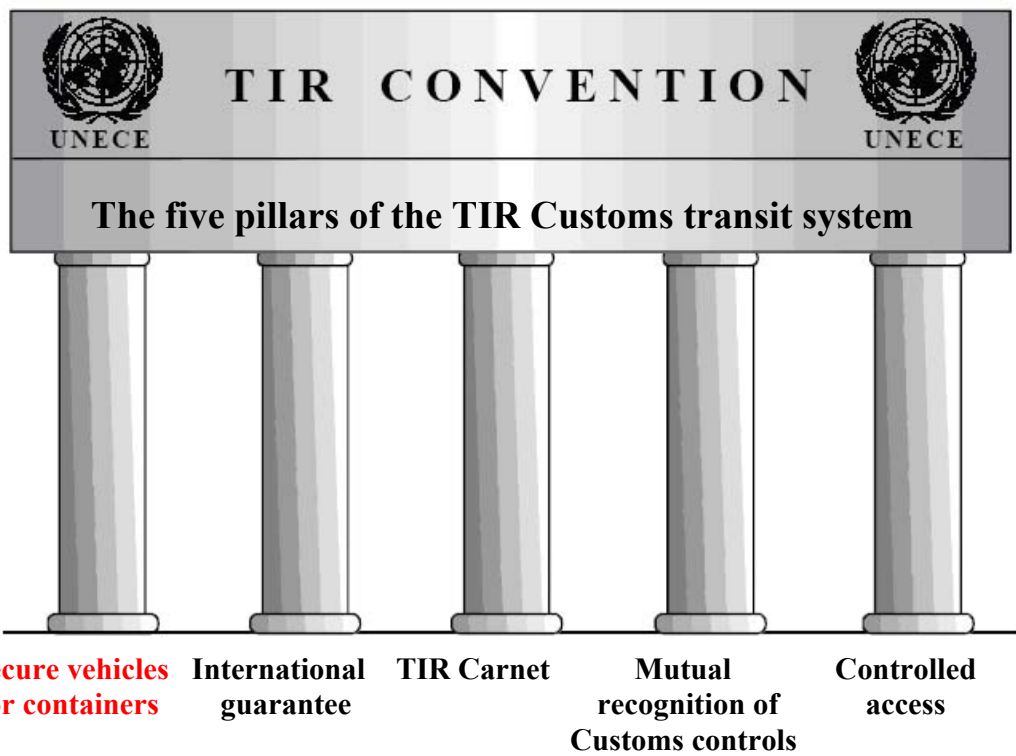

APPROVAL OF ROAD VEHICLES AND CONTAINERS

Concerning the requirement of security, the TIR Convention stipulates that goods shall be carried in containers or road vehicles the load compartments of which are so constructed that there shall be no access to the interior when secured by Customs seal and that any tampering will be clearly visible.

Towards this aim, the Convention sets out standards of construction and approval procedures, and goods may only be carried under cover of a TIR Carnet if the load compartment of the road vehicle or the container is approved in accordance with such requirements. If a container or a load compartment fulfils the requirements of the Convention, relevant national approval or inspection authorities issue so-called approval certificates for road vehicles or containers. In principle, these certificates shall be recognized in all Contracting Parties to the TIR Convention.

If national approval or inspection authorities are in doubt whether new constructions proposed by manufacturers are in line with the technical provisions of the TIR Convention, they may address themselves through their respective Governmental authorities to the TIR Executive Board and the TIR secretariat, to the TIR Administrative Committee or to the UNECE Working Party on Customs Questions affecting Transport (WP.30) and ask for an opinion on this matter. The UNECE Working Party and the TIR Administrative Committee may issue a comment or, if it is a major and generally applicable new construction not yet covered by the TIR Convention, prepare, if necessary, an amendment proposal for modification of the Convention.

Annex 2

REGULATIONS ON TECHNICAL CONDITIONS APPLICABLE TO ROAD VEHICLES WHICH MAY BE ACCEPTED FOR INTERNATIONAL TRANSPORT UNDER CUSTOMS SEAL

Article 1

Basic principles

Approval for the international transport of goods under Customs seal may be granted only to vehicles, the load compartments of which are constructed and equipped in such a manner that:

- a) no goods can be removed from or introduced into, the sealed part of the vehicle without leaving obvious traces of tampering or without breaking the Customs seal;**
- b) Customs seals can be simply and effectively affixed to them;**
- c) they contain no concealed spaces where goods may be hidden;**
- d) all spaces capable of holding goods are readily accessible for Customs inspection.**

Article 2

Structure of load compartments

1. To meet the requirements of Article 1 of these Regulations:

- a) the constituent parts of the load compartment (sides, floor, doors, roof, uprights, frames, cross-pieces, etc.) shall be assembled either by means of devices which cannot be removed and replaced from the outside without leaving obvious traces or by such methods as will produce a structure which cannot be modified without leaving obvious traces. When the sides, floor, doors and roof are made up of various components, these shall meet the same requirements and be of sufficient strength;
- b) doors and all other closing systems (including stopcocks, manhole-covers, flanges etc.) shall be fitted with a device on which Customs seals can be fixed. This device must be such that it cannot be removed and replaced from the outside without leaving obvious traces, or the door or fastening be opened without breaking the Customs seals. The latter shall be adequately protected. Opening roofs shall be permitted;
- c) apertures for ventilation and drainage shall be provided with a device preventing access to the interior of the load compartment. This device must be such that it cannot be removed and replaced from the outside without leaving obvious traces.

Vehicles:

1: Sheeted trucks and trailers:

- a) Sheet
- b) TIR-rings
- c) Thongs
- d) Hinges
- e) TIR-wire

2: Solid siders and Containers

3: Curtain siders

4: Tankers

5: Vans and small trucks

1. Sheeted Trucks and Trailers

The term “Sheeted Trucks” covers those trucks and trailers where the load compartment is covered - partly or fully - with either strong canvas, or rubberized or plastic-covered cloth. It is common for such trucks and trailers to have sideboards and rear doors.

On such trucks/trailers, as a minimum, the following parts should be checked prior to sealing:
The sheet and eyelets, thongs, TIR-rings and TIR-wire, hinges for sideboards and rear doors, and the door closing system (lock and sealing device).

Each part illustrated and described in the following Sections.

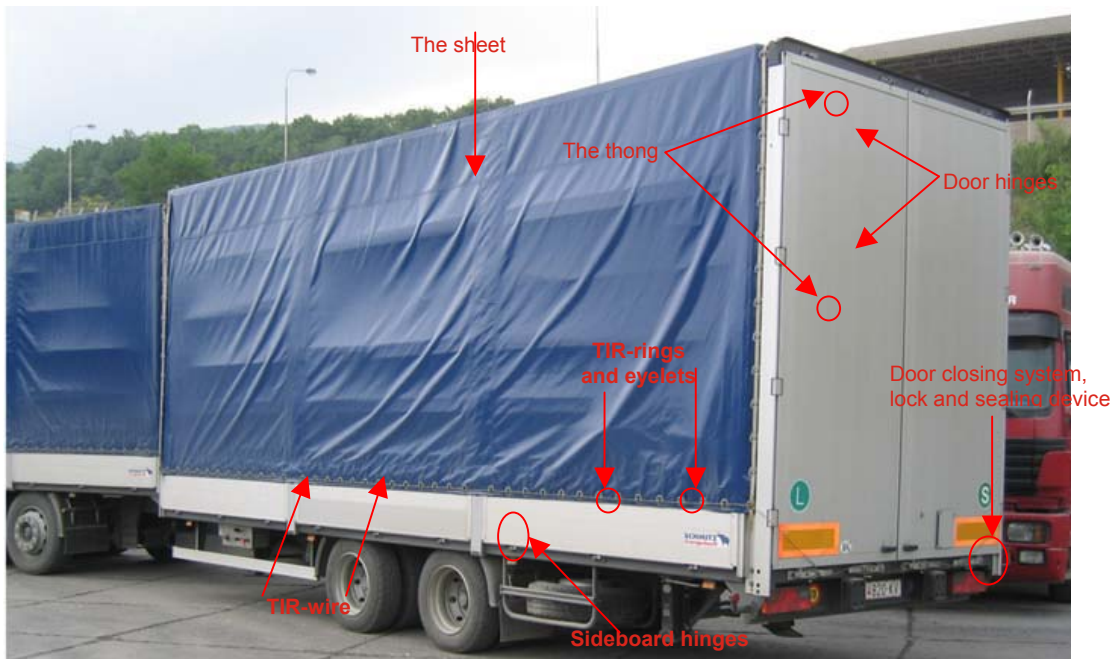

A: Side view of a trailer.

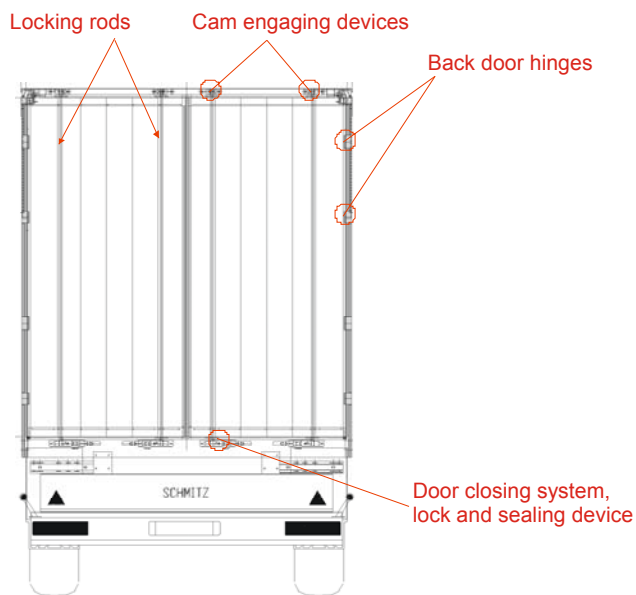

B: Rear view of the trailer.

a) SHEET

The sheet should be made either of strong canvas or plastic-covered or rubberized cloth, which should be of sufficient strength and unstretchable. It should be in good condition and made in such a way that once the closing device has been secured, it is impossible to gain access to the load compartment without leaving obvious traces. Only very small ventilation apertures can be accepted - provided that they do not allow direct access to the interior of the load compartment. Prior to sealing, special attention should be paid to: Company logos, horizontal sheet tension flaps, non repaired “cuts”, any old repair of the sheet, TIR-rings and the eyelets.



A: The sheet in perfect condition - without any: logos, damage, cuts or repairs. (The sheet for this truck is not equipped with ventilation apertures or tension flaps).

The sheet may be accidentally ripped during the journey. Usually this is not serious damage and can be easily noticed - (Pic. A and B). The upper part (roof) of the sheet is more difficult to check and therefore more likely to have openings for fraudulent purposes.

Special attention should be paid to those parts of the sheet containing inscriptions - (i.e. Company name or logo) - as they might cover repairs made incorrectly and be difficult to detect - (Pic. C).



A: Sheet ripped during journey, with rather extensive damage. This trailer should NOT be allowed to continue to transport under customs seal - unless it is repaired.



B: Sheet ripped during journey, with minor damage. Dependent on the commodity being transported, this trailer COULD be allowed to complete the current journey - but should NOT be able to carry out further international transport without being repaired.

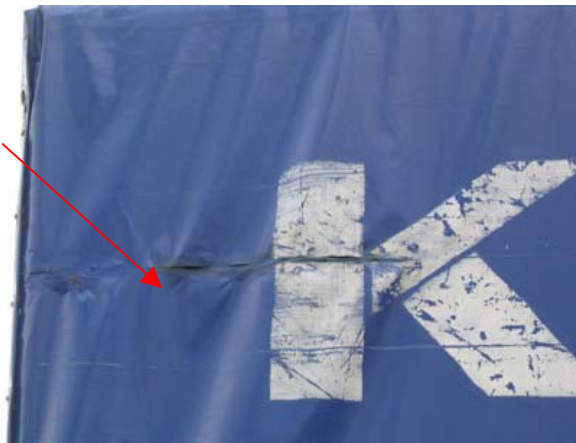

C: Company logo covering repair made incorrectly - sheet repaired by using adhesive tape on the inner side of the sheet.

A truck or trailer cannot be approved for carrying out the transport of goods under customs seal if the sheet is ripped - especially if the damage is combined with a row of missing eyelets (Pic. A and B).

Repairs should be made by professionals, as only very few methods of repairing the sheet are approved. Unauthorized or “homemade” repairs should not be approved (Pic. C and D).

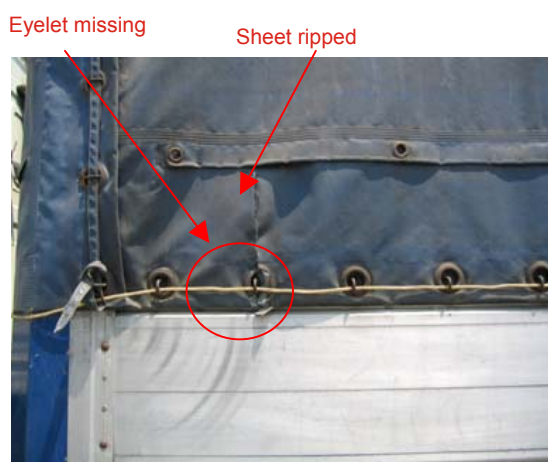

A: Eyelet missing, sheet torn – minor damage (only one eyelet missing – not several in a row).

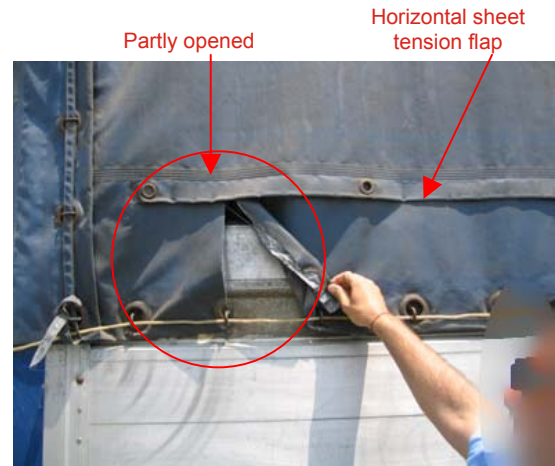

B: Limited access to the load compartment. Dependent on the commodity being transported, the trailer could be allowed to complete its current journey. Notice the sheet tension flap - there could be damage behind this.



C: The sheet repaired with adhesive tape only.
Unauthorised (homemade).



D: It is very easy to gain access to the load compartment.

Sheet fixing system

The sheet shall be fixed to the vehicle in strict compliance with the conditions set forth in Article 1(a) and (b) of these Regulations.

The following system is the most commonly used:

- (a) The sheet can be secured by:
- (i) metal rings fixed to the vehicles (TIR-rings),
 - (ii) reinforced eyelets let into the edge of the sheet, and
 - (iii) a fastening (TIR-wire) passing through the rings above the sheet and visible from the outside for its entire length.
The sheet shall overlap solid parts of the vehicle by at least 250 mm, measured from the centre of the securing rings, unless the system of construction of the vehicle in itself prevents all access to the load compartment.
- (b) The sheet shall be supported by an adequate superstructure (uprights, sides, slats, arches, etc.).
- (c) The spaces between the rings and the spaces between the eyelets shall not exceed 200 mm. The spaces may however be greater but shall not exceed 300 mm between rings and eyelets on either side of the upright of the construction.
- (d) The following fastenings shall be used:
- (i) steel wire ropes of at least 3 mm diameter; or
 - (ii) ropes of hemp or sisal of at least 8 mm diameter encased in a transparent sheath of unstretchable plastic.

Wire ropes may have a transparent sheath of unstretchable plastic.

The sheet for the trailer is fastened with eyelets and rings at the sideboard, so-called TIR-rings. The number of eyelets and TIR-rings should be equal and each eyelet should directly correspond a TIR-ring.

The TIR-ring should be mounted to the sideboard with solid rivets, or in a way that makes it impossible to remove the TIR-rings without leaving visible traces - (Pic. A).

Merging the side cover sheet and the rear part of the sheet requires an overlap system - (Pic.B).



A: Properly mounted TIR-rings and eyelets.

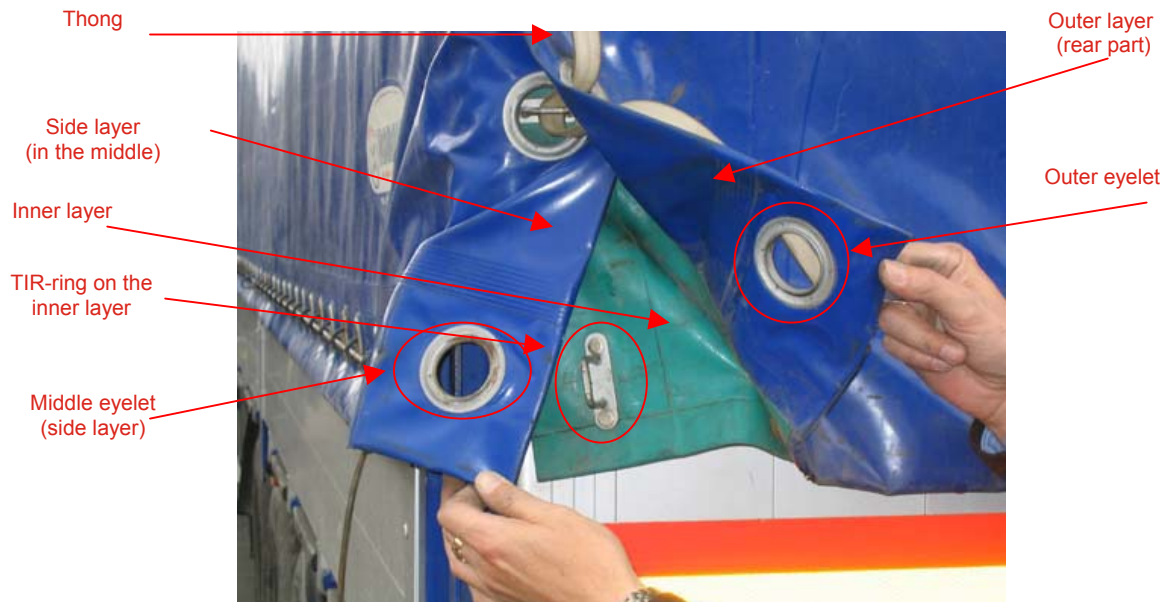

B: Sheet overlap system at the rear corner of the trailer.

b) TIR - RINGS

Some manufacturers of trailers prefer to install a folding type of TIR-ring in the welded pillars, which support and contain the locking mechanisms for the sideboards - Pic. A. This means, that in folded out position - and secured by the TIR-wire - the TIR-ring will not only secure the sheet to the pillars, but also serve as a lock for the vertical movement of the locking pins and the sideboards cannot be released. Always make sure that this TIR-ring is in use - if installed. An incompatible sheet for the truck/trailer and (or) missing TIR-rings results in incorrect closure of the vehicle and makes it possible to get access to the load compartment - Pic. B. Damage or adaptation of the TIR-rings or eyelets are a risk as they are difficult to detect. If several TIR-rings in a row are damaged it is easy to get access to the load - Pic. C.

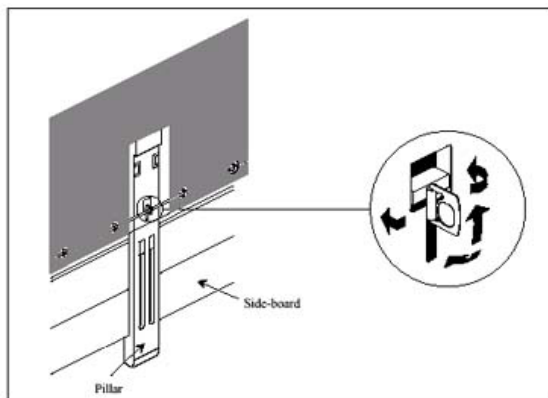

A: Folding type of TIR-ring - integrated pillar and sideboard locking mechanism.

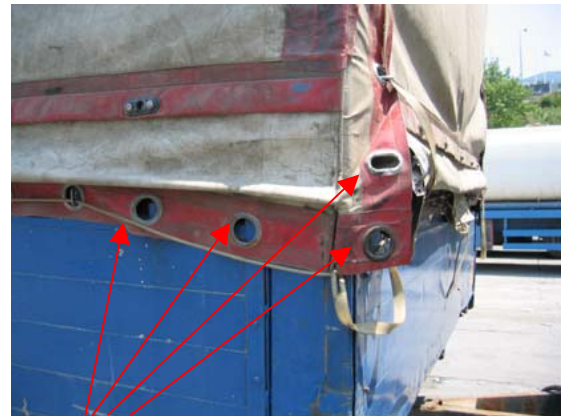

B: TIR-rings missing or sheet does not fit the trailer.

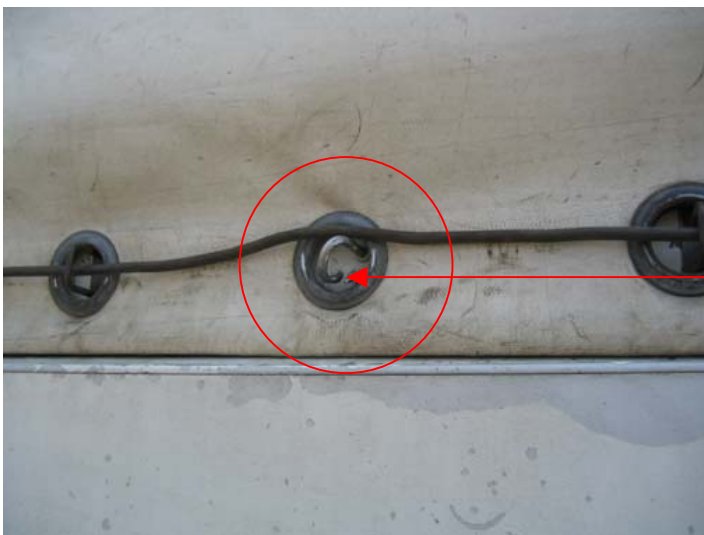

C: TIR-ring open - TIR-wire can pass and sheet released. In this case a typical example of wear and tear and not adaptation.

The TIR-rings must be fitted properly to the sideboard - either by using solid rivets or blind rivets (so-called “pop-rivets”). Using bolts and nuts is accepted provided the nut is on the inner side of the sideboard and the nut is secured by welding or riveted. On all trucks and trailers having wooden sideboards it is good practice to check behind the eyelets.

TIR-rings being fitted as shown on Pic. A and B cannot be accepted. “Homemade” TIR-rings as shown on Pic. C are also not acceptable.



A: Truck with wooden sideboards - it is easily spotted that the TIR-rings have been moved several times. Note the brand new screws.

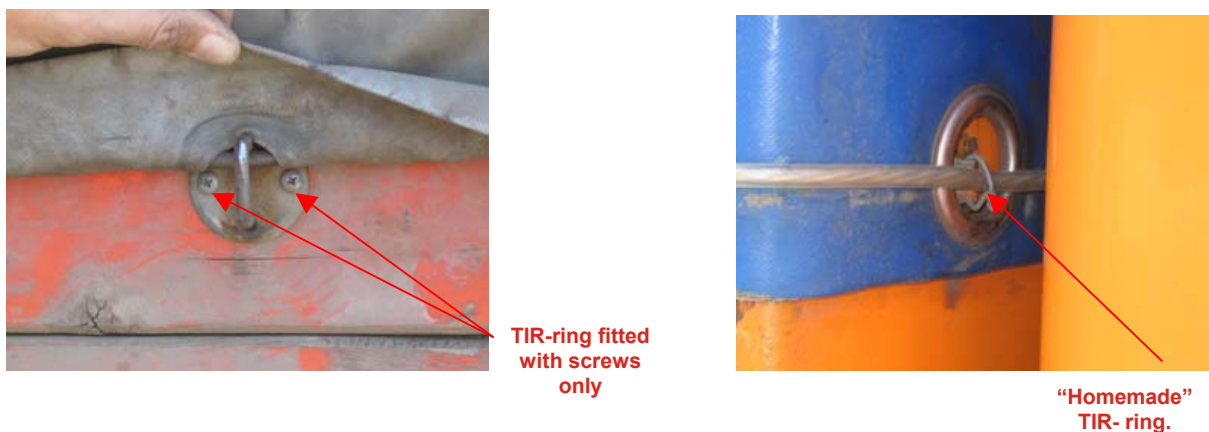

B: TIR-ring fitted with screws, very easy to remove.

C: “Homemade” TIR-ring, easy to cut or open.

c) THONGS

Sheet thongs are normally located at each corner of the trailer only - but in some cases an additional thong is allocated at the centre.

The following materials are regarded as suitable for making thongs: Leather, or non-tensile materials including plastic-covered or rubberized cloth, provided that such materials cannot, after severance, be welded or reconstituted without leaving obvious traces. Furthermore, the plastic material used to cover thongs must be transparent and smooth-surfaced.

The thong shall be secured and mounted with rivets to the inner layer of the sheet which makes it impossible to remove or replace without cutting the sheet - Pic.A, B, C and D.



A: Thong - inserted through a special hole for passing through all layers of the sheet.
(Upper front part of the trailer)



B: Thong secured - mounted to the INNER layer of the sheet.
(Upper front part of the trailer)

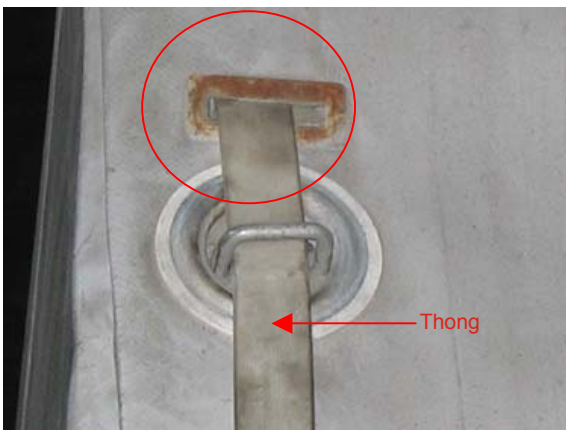

C: Thong - inserted through a special and reinforced hole - passing through all layers of the sheet.
(Upper back part of the trailer)

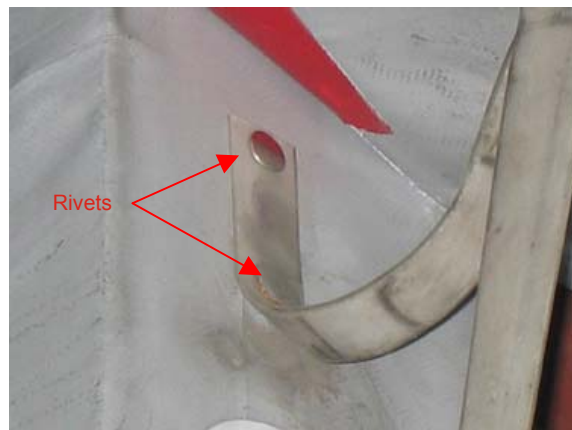

D: Thong secured - mounted to the INNER layer of the sheet.
(Upper back part of the trailer)

Some manufactures of trailers and sheets prefer to use “Self-locking” thongs. For such systems it is important that the locking part can be inspected from outside - Fig. A.

Securing the thong with the TIR-wire can be made in two ways: either having a hole matching the shape of the TIR-ring, or just a hole through which the TIR-wire can pass - Fig. B. In both cases it is preferable that the holes are reinforced.

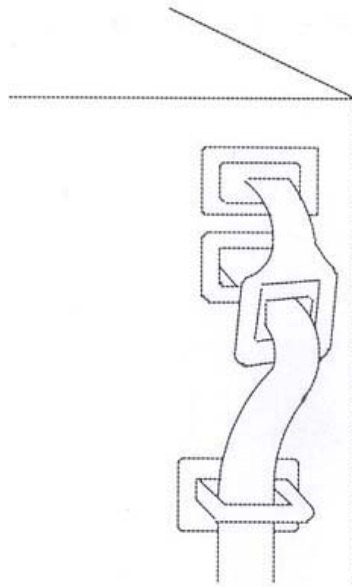

A: Thong - “Self -locking” system.

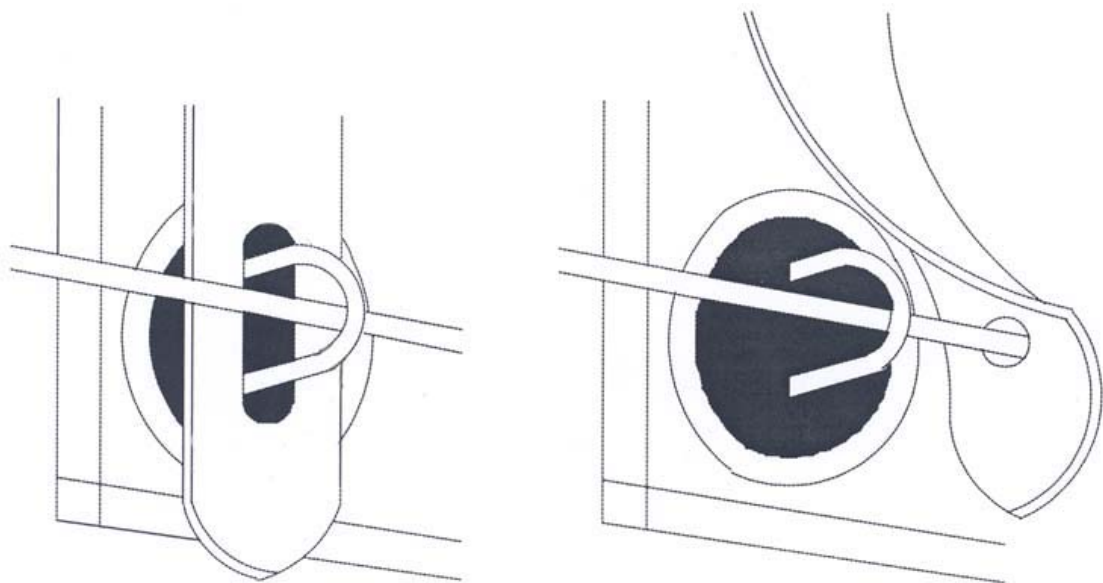

B: Examples of securing thongs with the TIR-wire.

Thongs should be fitted, replaced or repaired by professionals only. It is common to find trucks and trailers having thongs replaced and the new thong being fitted in an unauthorized way - Pic. A, B and C.

The “pop-riquet” securing the thong can easily be removed (and a new one inserted) – leaving direct access to the load compartment - Pic. D.



A: Thong fitted with a “pop-riquet”.
Note that is a brand new rivet!
OUTSIDE view.

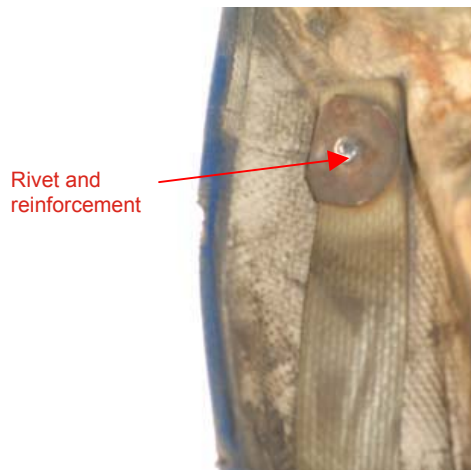

B: “Pop-riquet” and reinforcement.
When was it last replaced?
INSIDE view.



C: Thong fitted only to the outer layer of the sheet - making it easy to replace the rivet.



D: Good access when thong is removed.

A wide range of unauthorized or “homemade” repairs of the thong can be found; the examples shown below - Pic. A, B, C, D and E - are just few. Trucks and trailers equipped with such poorly repaired thongs should not be allowed to carry out international transport - and certainly not any transport of goods under customs seal.



A: Thong - joined outside (with rivets).



B: Thong repaired or joined with an extra layer of textile and sewing.



C: Thong repaired or joined with tape.



D: Thong, cut or broken, repaired - joined with blind rivets.



E: Thong repaired - joined with adhesive tape.

During check and inspection of trucks and trailers - prior to sealing - it is good practice to pull all thongs firmly in order to make sure that they are properly fitted and of sufficient strength. The thongs should pass through ALL the TIR-rings fitted to the sheet overlap, not leaving any openings for access to the load compartment. Furthermore the thongs should be visible, not hidden behind ANY part of the sheet.

The truck shown below - Pics. A, B and C - have been sealed although the thong does not pass 7 of the TIR-rings, leaving an opening of approximately 150 cm - enough for a person to enter the sealed compartment.



A: Thong not passing through 7 TIR-rings.



B: Sheet overlap easy to open - leaving occasionally - of 150 cm. - it is possible to find trucks



C: Although not secure, the truck has been sealed (SEMI LOCK seal) the most basic standards.

The truck shown below - Pics. A and B - is not equipped with thongs, but elastic rope, only catching small hooks for securing the sheet at each corner. It is evident that additional – and significant - work and accessories are required for making such trucks acceptable, if carrying out international transport.

Requirements: Approved sheet overlap, TIR-rings, eyelets and thongs - all properly made and fitted.



A: No thong - only elastic rope and hooks. Note that the rope does not even match in length. (Rear view of the truck).



B: No thong - only elastic rope and hooks.
(Front view of the truck)

d) HINGES

Sideboard hinges are considered as secure if the pin cannot be removed from the bearing when the sideboard is in vertical position (closed). Most manufacturers of trucks and trailers prefer to install so-called “self-securing” hinges - and a wide range of such hinges are available. A few examples shown below: Pic. A, B, C and D.

In general all hinges are vulnerable parts - exposed to wear and tear - so by just a distant view of a truck or trailer it is possible to estimate the standard - Pic. E.

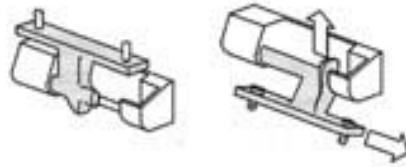

A: “Self-securing” sideboard hinge.
(A version of today)

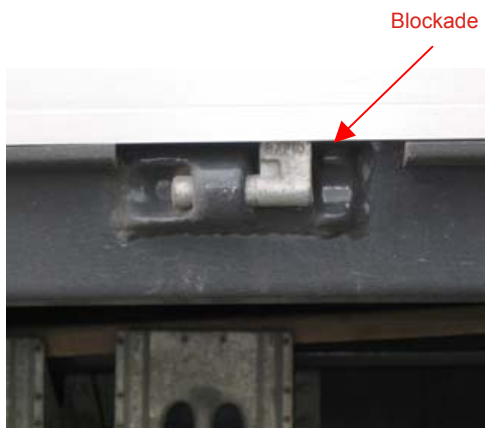

B: ”Self-securing” hinge - sideboard.
(A current version)



C: “Self-securing” hinge - sideboard.
(Old-fashion version)

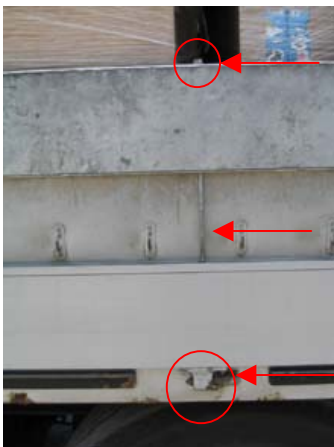

D: Hinge secured by a long bolt inserted through the sideboard. Access to the bolt is impossible as it will be covered by the sheet when closed.



E: Trailer in good condition - no damages to sideboard- or rear door hinges

Hinges for sideboards cannot be considered as secure if it is possible to remove or replace the pin for the pivoting point. Trucks and trailers of an earlier date are often fitted with unsecure hinges, or hinges that have been subject to repair and irregular maintenance.

The bolt inserted as a pin - Pics: A and B - cannot be considered as securing the hinge. The nut and head should be cut off, leveling the outer of the bearing, and properly welded. The bit of metal bar inserted as a pin - Pics: C and D - cannot be considered as securing the hinge. The split pins are easy to remove and the pin taken out. The hinge can be adapted to be secure if the pin is cut and welded properly - see Pic. B.



A: Unsecure hinge for sideboard.
(Truck of an earlier date.)

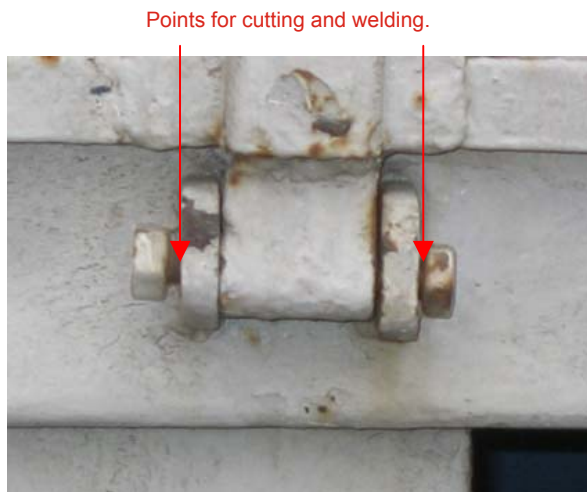

B: The unsecure hinge can be adapted by cutting off the head and nut leveling the outer of the bearing and then welding.

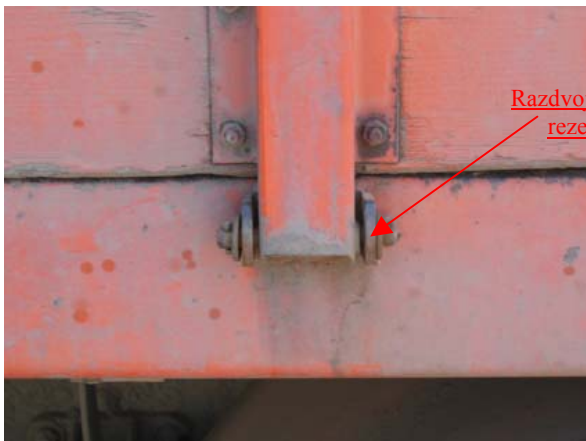

C: Unsecure hinge for sideboard.
(Truck of an earlier date.)



D: This hinge can be adapted to be secure - using the same procedure as described at Pic. B.

A trailer is normally equipped with 3 or 4 sideboards at each side, each sideboard having 3-4 hinges. Current versions of trailers will be fitted with sideboard hinges partly integrated to the aluminium profile for the sideboard itself. It is important that the bolts for securing the sliding part (bearing) are secured by welding.

Unauthorized repair or replacement of sideboards are always a risk factor - note the profiles for the sideboards on the trailer shown below. A close inspection reveals that the two bolts for each integrated part, the sliding bearings, are not secured (not welded) - Pic. A.

It is easy to loosen the bolts and then slide the bearings off the pins - Pics. B and C – leaving limited, but still unacceptable, access to the load compartment - Pic. D.

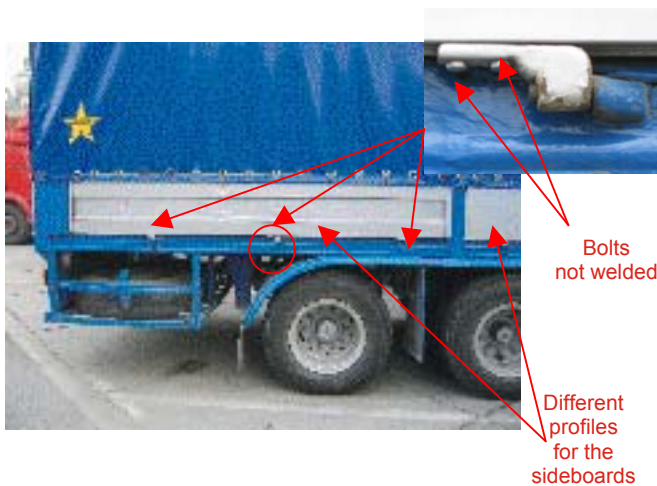

A: Different profiles for the sideboards - indicates replacement. Bolts for the hinges not secured (not welded).

B: It is easy to loosen both bolts by using a standard wrench.

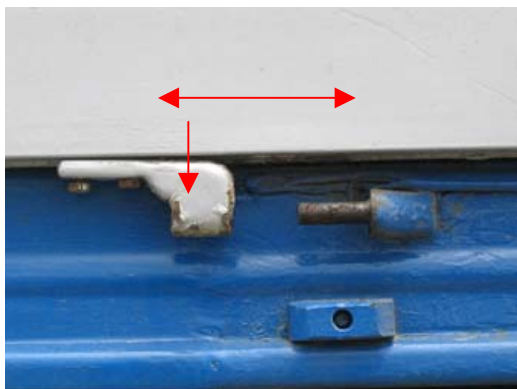

C: Bearing can be slid off the pin.



D: Limited - but still unacceptable - access to load compartment.

Occasionally it is possible to find trucks and trailers not manufactured to carry out international transport - but they do it anyway. The truck shown below is an typical example of a truck only meant to carry out domestic transport.

The hinges for the sideboards are wide open, as the “pins” are an integrated part of the sideboard and the “bearings” are an integrated part of the chassis. Each sideboard is only secured by the locking system and a single - but solid - metal ring, located and welded to the chassis next to the pillar. Pics. A, B and C.

Sequences: 1. - Release the lock system by pulling the handle. 2. - Release the sideboard from the locking pins by pulling the upper part of the sideboard. 3. - Lift the sideboard off the hinges. 4. - Pull the sideboard and there is access to the load compartment - Pic. D.



A: Open hinges - the sideboard only being secured with the locking system and a single metal ring.



B: The “open” hinge, the solid metal ring and the vertical maneuver handle for the lock system.



C: Note the “open” hinge and the spacious ring.



D: Release the lock system, lift the sideboard off the hinges, and there is access to the load compartment.

e) TIR - WIRE

The final element for fastening the sheet is the so-called TIR-wire. The following international standards should be applied:

The TIR-wire should be made of:

1. - Steel wire rope of at least 3 mm diameter, that may have a transparent sheath of unstretchable plastic.
2. - Rope of hemp or sisal of at least 8 mm diameter, encased in a transparent sheath of unstretchable plastic.

Nylon ropes in plastic sheathing are NOT permitted as they are elastic (stretchable).

The length of the TIR-wire shall correspond exactly to what is required for each individual truck or trailer - no extra length shall be hidden anywhere, i.e. as loops between the TIR-rings.

The TIR-wire shall be in one piece and have a hard metal end-piece at each end. The fastener of each end-piece shall include a hollow rivet passing through the rope so as to allow the introduction of the thread or strap of the Customs seal. The rope shall remain visible on either side of the hollow rivet so that it is possible to ensure that the rope is in one piece. Pic. A.

A: Example of an end-piece.

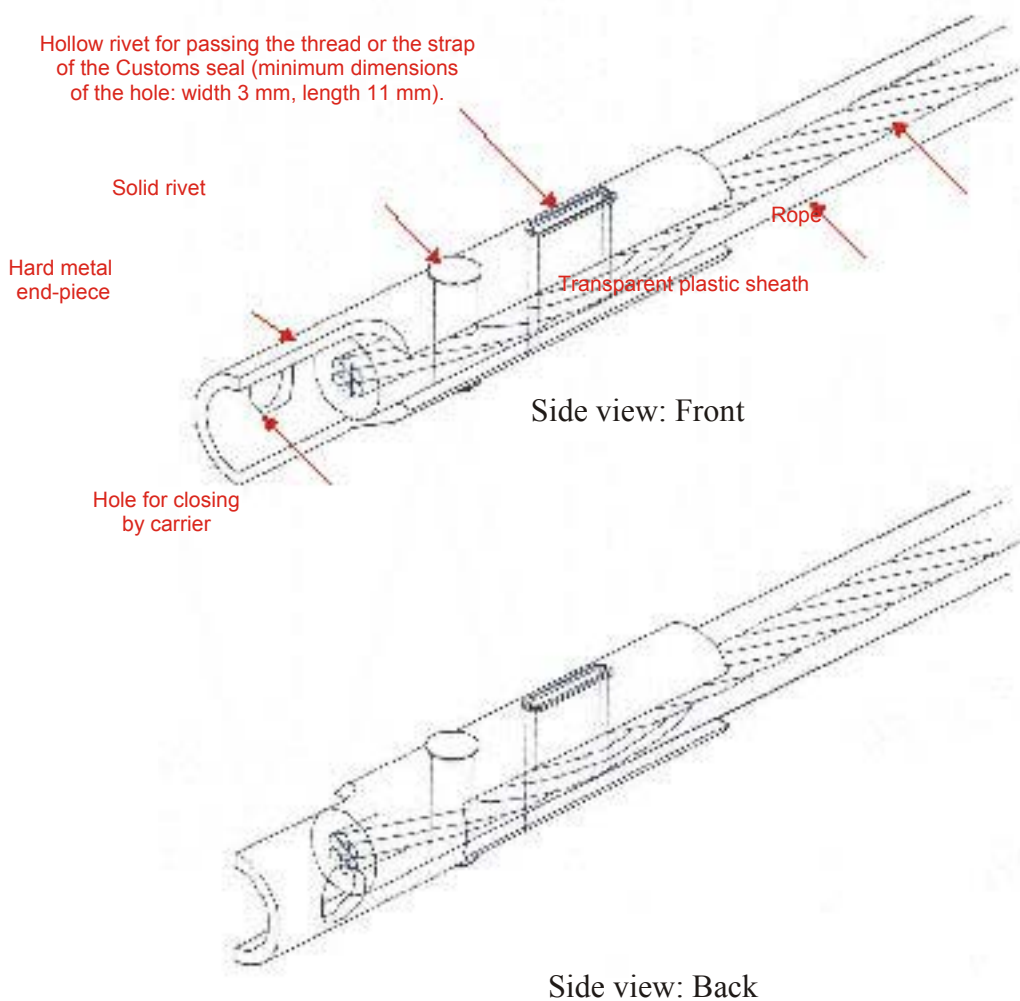

It is common to find trucks and trailers equipped with irregular TIR-wires and end-pieces.

Nylon rope with homemade end-pieces are shown below as an example - Pic. A and B.

Broken or cut (adapted) TIR-wires are often found to be jointed by use of short pieces of copper or aluminium pipe - Pic. C.

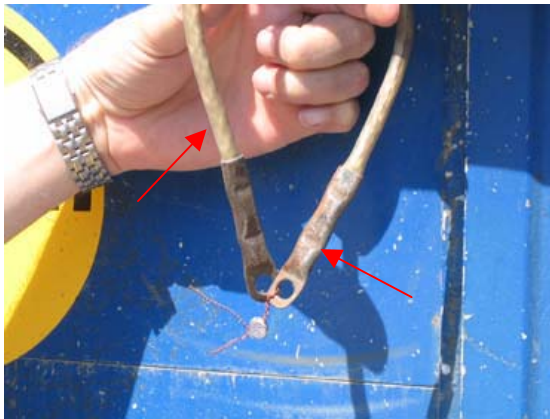

A: Nylon rope in plastic sheathing with homemade end-pieces.



B: End-pieces made of copper pipe – just pressed onto the rope. Easy to open and put back on.

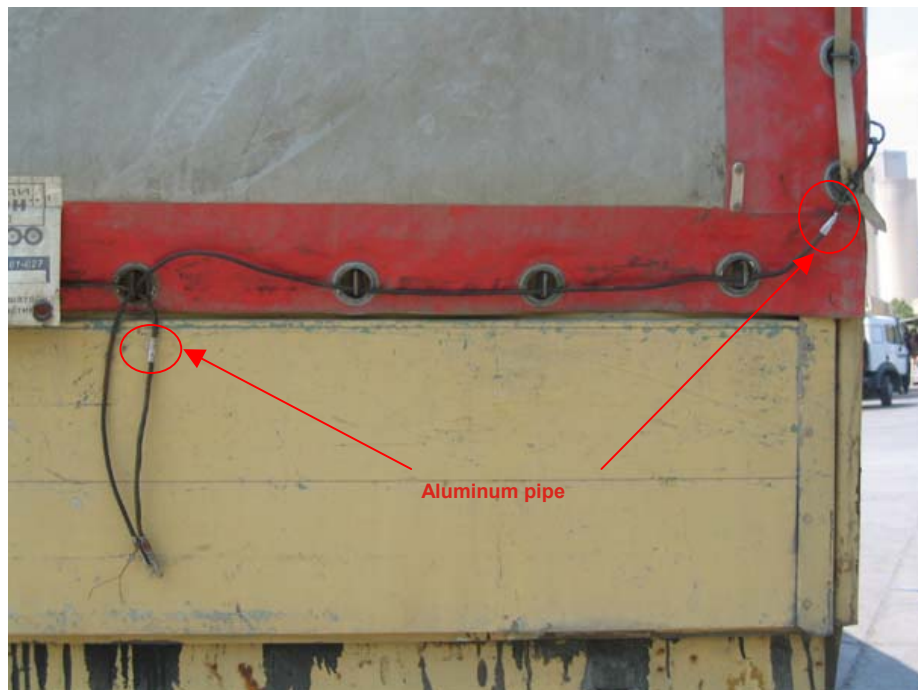

C: TIR-wire repaired at two places. The broken wire is jointed with pieces of aluminium pipe.

Replacement of broken, damaged or cut TIR-wires should be requested immediately when found - trucks or trailers equipped with such wires should not be allowed to carry out transport under customs seal. Such repairs as shown below - Pic. A and B - are unacceptable, as it is impossible to determine whether or not the wire is broken, the sheathing just being damaged and the steel cord being rusty, or it is made on purpose (adaptation).

An obvious way - and easy to discover - of repairing a broken wire is to make loops by using pieces of wire to secure the ends (twisted) - Pic. C.

It is even possible to find broken TIR-wires being jointed by the use of a Customs Seal - Pic. D.



A: TIR-wire cut or broken - repaired with a piece of copper pipe.



B: TIR-wire repaired with a piece of copper pipe. Note the shiny copper - when was it last replaced?



C: Broken TIR wire repaired - two loops made, the ends being secured by thin steel wire, twisted.



D: Rather unusual joining of a broken or cut wire. Jointed behind the cabin with a CUSTOMS SEAL.

It is quite common to find repairs being camouflaged. In most cases this camouflage is made by using adhesive tape or plastic material. In most cases the driver will claim that the plastic sheathing for the TIR-wire is damaged, and the tape is put on only to prevent the steel cord from getting rusty.

As recommended good practice, such camouflage should always be removed - and in most cases the wire is found to be broken and repaired (jointed).

The pictures below - Pic. A, B and C - illustrate such camouflaged repair of a TIR-wire.



A: TIR-wire wrapped with adhesive tape.
(Camouflage)



B: Removal of the tape revealed the
jointed TIR-wire.



C: TIR-wire jointed with a piece of wire –
just twisted and easy to replace.

The TIR-wire shall remain visible everywhere and easy to inspect. Special attention should be paid to parts where the TIR-wire is hidden behind the sheet.

Quite often such hidden parts will reveal damage, repair or adaptation of the TIR- wire.

Illustrated below are two examples of such hidden TIR-wire, Pics. A+B and C+D.



A: TIR-wire hidden behind the sheet.

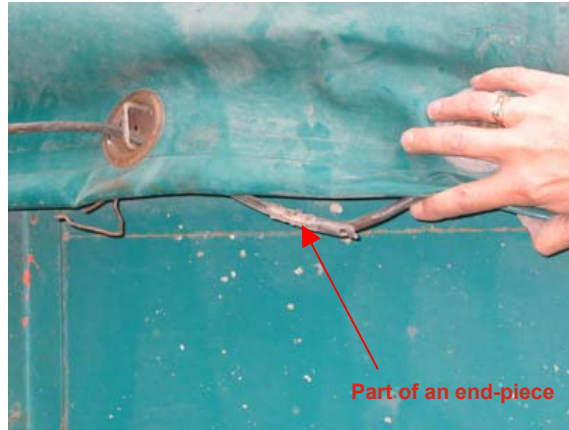

B: TIR-wire jointed - a part of an end-piece being used.

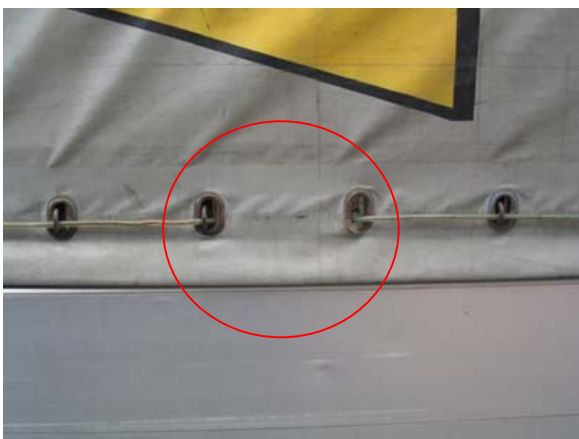

C: TIR-wire hidden behind the sheet.



D: TIR-wire jointed - a piece of aluminium pipe being used.

The TIR-wire shall correspond exactly to what is required for each individual truck or trailer. No extra length shall be hidden anywhere, i.e. as loops between the TIR-rings. In most cases such extra length will be hidden at places difficult to inspect, i.e. next to the junction-box for electrical and brake connections - Pic. A and B, or behind the cabin - Pic. C and D. Substantial extra length of TIR-wire can be found in some cases - Pic. E.



A: TIR-wire hooked up next to the junction box.

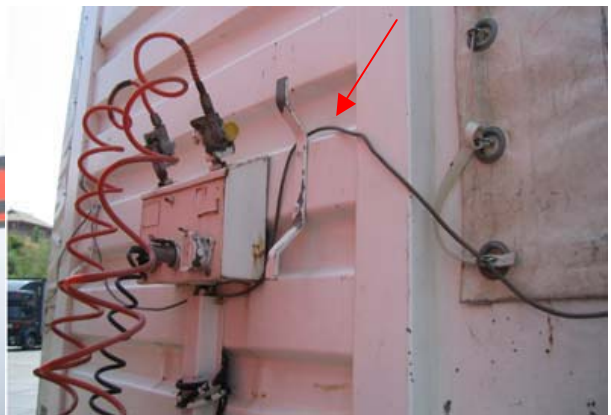

B: TIR-wire hooked up next to the junction-box. Approximately 60 cm extra length hidden.

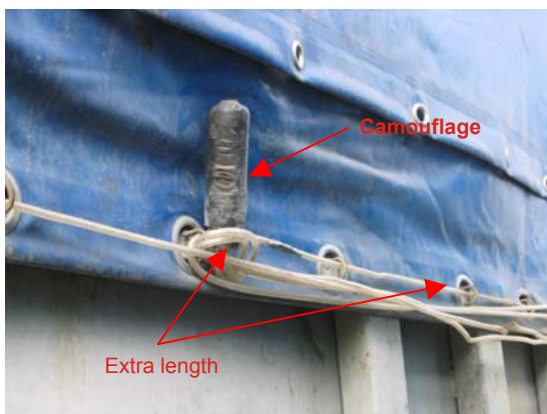

C: TIR-wire, extra length hidden and poorly camouflaged.

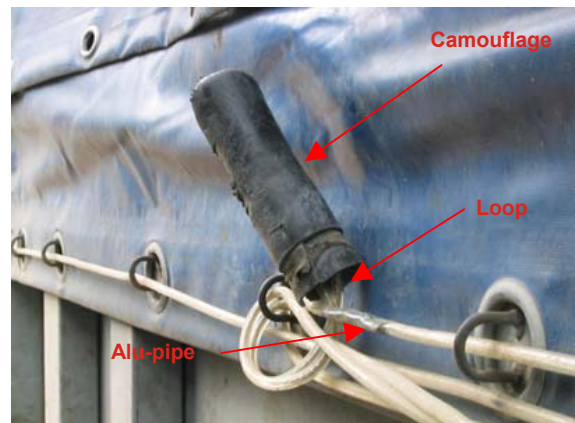

D: Plastic pipe used as a cover for the folded end loop. Note the aluminium pipe - repair of cut or broken wire.



E: The hidden extra length unfolded. Approximately 5 meters was hidden.

It is important that the TIR-wire is passing through all TIR-rings - and special attention should be paid to corners where the thongs are meant to be secured by the TIR-wire - Pic. A.

If not secured it is very easy to remove the thong - Pic. B - and get access to the load.

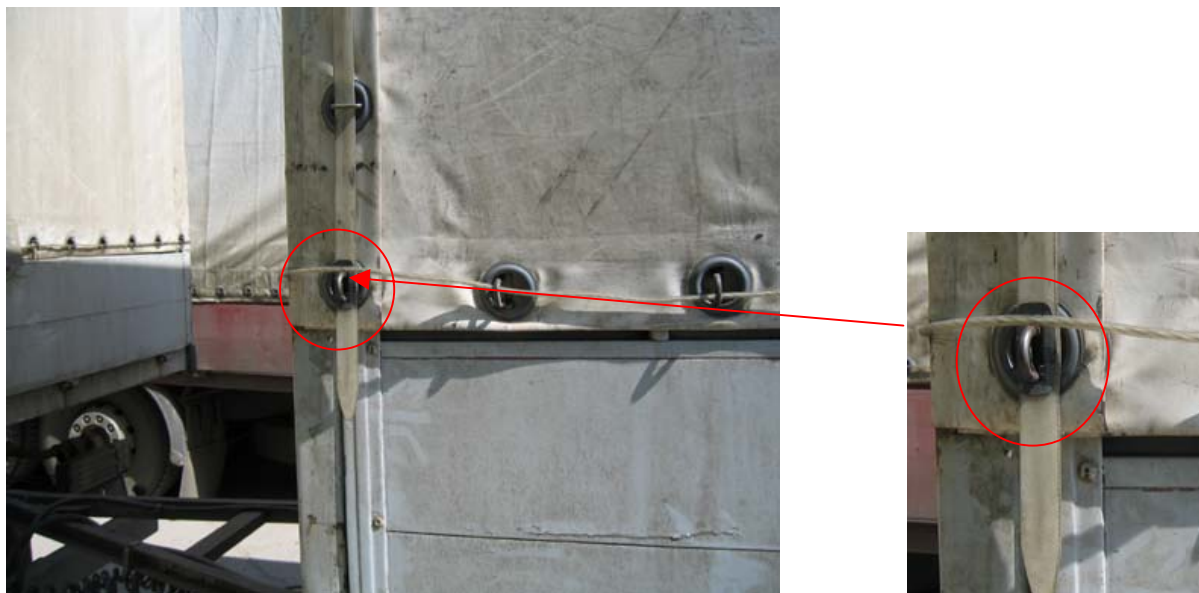

A: TIR-wire not passing through one of the most important TIR-rings - the one securing the thong.



B: Easy to remove / release the thong and get access to the load.

A very good practice when sealing sheeted trucks and trailers equipped with rear doors, is to make sure that the TIR-wire is having the exact length required - and make sure that it is impossible to release the pivoting device and the maneuver handle.

The combination of the TIR-wire being too long and the maneuver handle not being secured by the pivoting device, makes it very easy to get access to the load compartment - Pics. A+B and C+D.

There are two options available to secure such vehicles - option 1 being the preferred one:

1: - By using one customs seal - securing both the end-pieces of the wire and the pivoting device/maneuver handle.

2: - By using two customs seals - one seal for the wire and one seal for the pivoting device/maneuver handle.

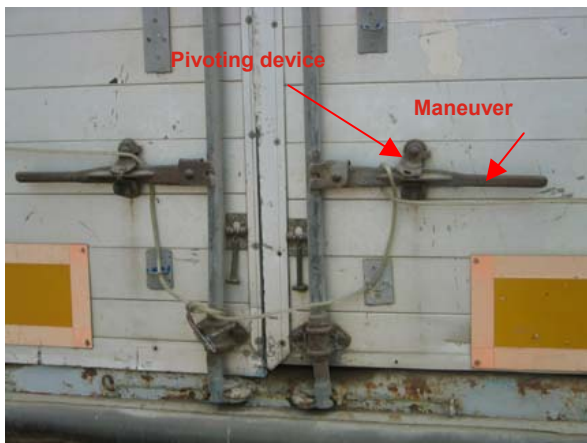

A: TIR-wire too long - maneuver handle not secured. Wire not even passing through the hole in the pivoting device and handle.



B: Pivoting device OPEN, handle and locking rod released.



C: TIR-wire too long - maneuver handle not secured. Wire not even passing through the hole in the pivoting device and handle.



D: Just 1 meter of extra wire makes it possible to open the door widely.

Due to wear and tear the gap between the handle and the pivoting device will - sooner or later- be enlarged. It is then possible to rotate the pivoting device - squeezing or pressing the wire - and this combined with a long TIR- wire makes it possible to open the rear doors and gain access to the load compartment.

It is a must that the pivoting device, the handle - and the wire are properly secured and sealed.

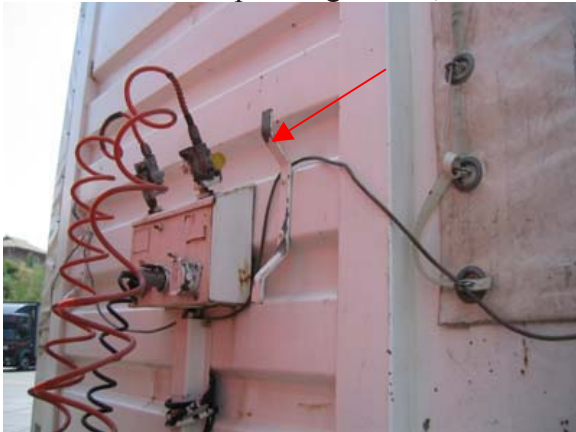

A: Approximately 50cm of extra wire hidden.

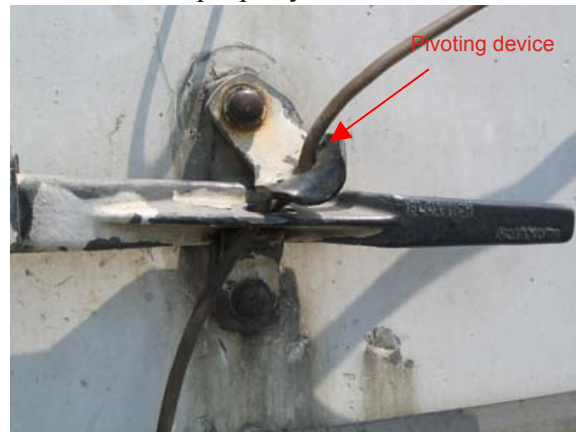

B: It is possible to rotate the pivoting device.

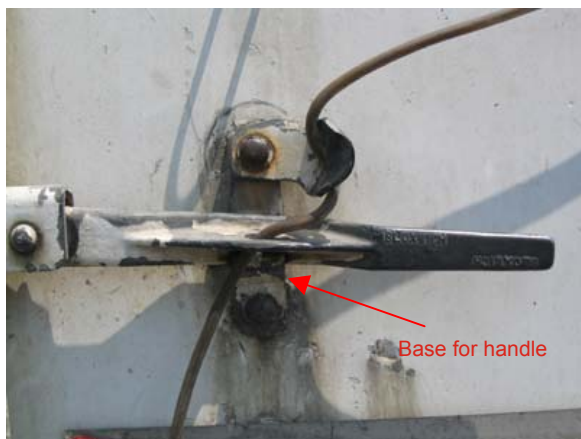

C: Easy to lift the handle from the base.



D: Maneuver handle in free position – and the door can be opened.



E: Access to the load compartment.

2. SOLID SIDERS AND CONTAINERS

Special attention should always be paid to the door closing systems prior to affixing Customs seals, as such systems are easily manipulated. No matter what type of truck or trailer - i.e. sheeted truck with rear doors, refrigerated truck with rear or side doors, or a truck having “solid” sides - it is a must that the system and the sealing device are carefully inspected and are used correctly. Pics. A and B illustrate just two examples of door closing systems, but a wide range exists and constantly new systems are invented, approved and introduced.

Examples of Customs secure door closing systems.

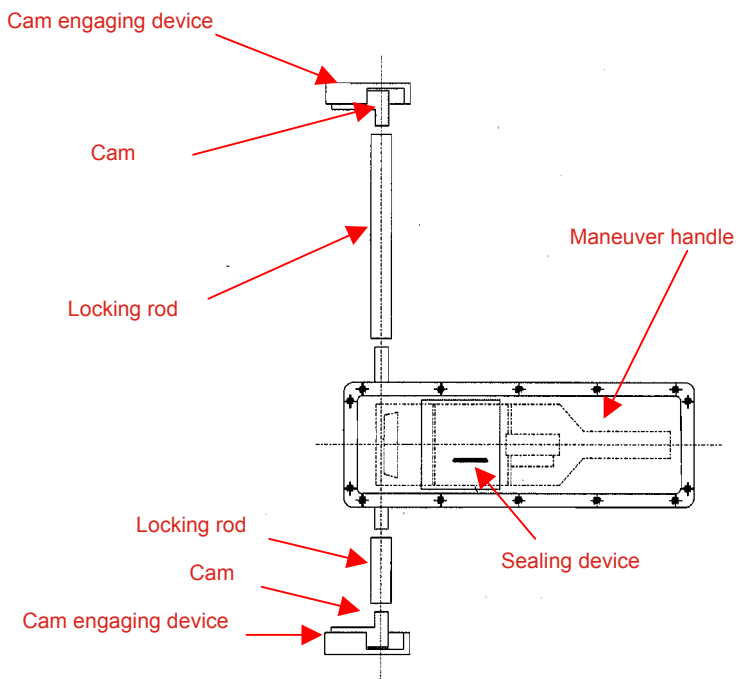

A: Current version - common for refrigerated trucks and trailers

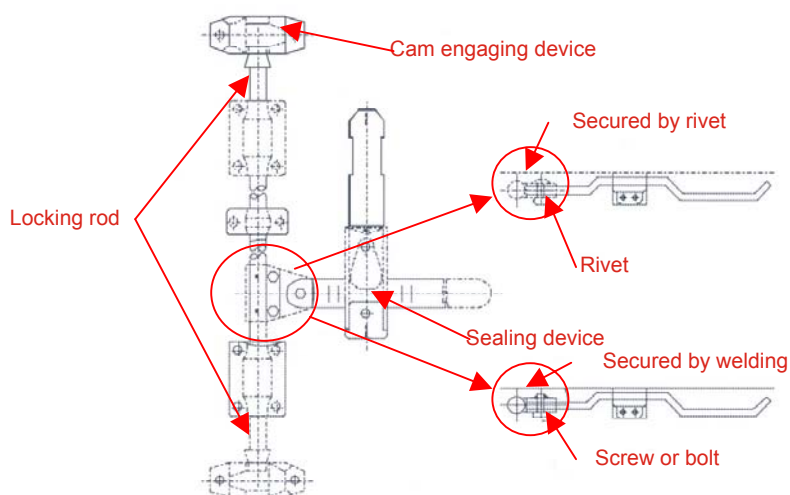

B: Standard version - used for “sheeted” trucks as well as for trucks having solid sides (“non-sheeted”).

Illustrated below is a refrigerator trailer equipped with side door. Due to only limited inspection, wear and tear of the sealing device and the string (wire) not being pulled tightened) as much as possible - leaving a large loop - it is possible to open the door without breaking the seal. ALWAYS fix the Customs seal at tightly as possible - not leaving any loop or additional thread. If the seal is fixed very tightly it is far more difficult to manipulate the thread (wire) or the sealing device.



A: Refrigerator trailer with side door.



B: Sealing device and "Semi-lock" seal. Note the loop - 6,5 cm!



C: The wire can pass the sealing device and the handle can be released as much as 75E.



D: Wire can pass - visible behind handle (inside).



E: Semi-lock seal stays outside the handle. Now it is possible to pull the handle and open the door.



F: Access to the load (cheese). Seal not broken.

It is good practice always to make sure that all devices such as locking systems and sealing devices are intact and functioning accordingly. Illustrated below is a refrigerated trailer where the handle and device for correct sealing are only functioning on the door at the left hand side - Pic. A.

The handle for the door at the right hand side is broken - leaving this door without the correct sealing device in working order. Instead the officer affixed the Customs seal at the device which is normally used for the carriers own security measures - i.e. a pad-lock - Pic. B.

As this specific type of seal can not be tightened - manufactured with a specific length – and the metal strip for the seal can pass the eyelet in the “sealing device”, it is possible to turn the handle and locking rod enough to open the door without breaking the seal - Pics. C and D.

Full access to the load compartment, and note the TIR - approval - Pic. D.



A: Handle and sealing device - left hand side.

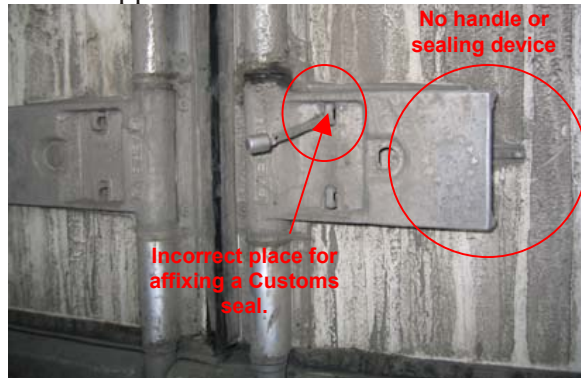

B: Handle and sealing device missing – right hand side - seal affixed incorrect.

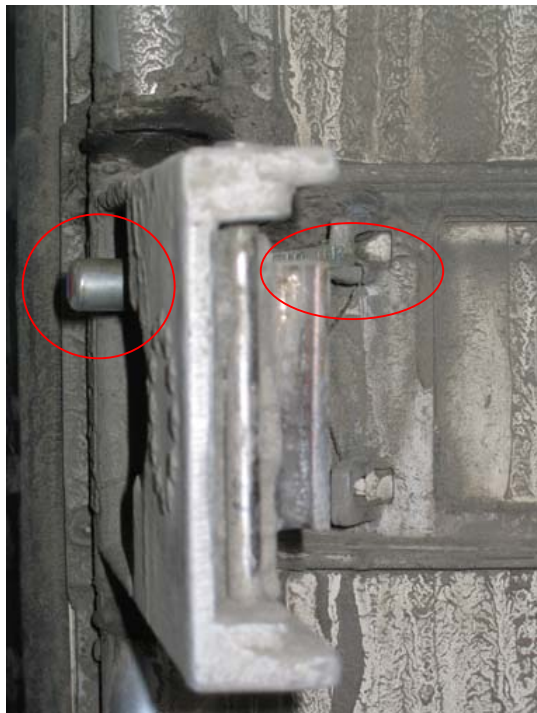

C: Handle turned, locking rod activated - the metal strip for the seal can pass, the actual seal itself remains unbroken.



D: Handle turned, locking rod activated - door open - seal remain unbroken.



E: Full access to the load.
Note the TIR approval.

Current versions of sealing devices are equipped with a specific hole for affixing the Customs seal and it is important that this is used. As illustrated below it is very easy to get access to the load compartment if only the TIR-wire is sealed. Only 30-40 cm extra length of the TIRwire is enough for a person to enter the load.

Furthermore it is essential to make sure that an effective blockade of an unsealed door is in place. Normally the door at the right hand side will block and secure the door at the left hand side, but it can be the opposite way. If any doubts - seal BOTH doors!

Concerning the trailer illustrated below, no effective blocking device is in place - only the rubber profile is meant to secure the door at the left hand side - so in this case both doors have to be sealed.

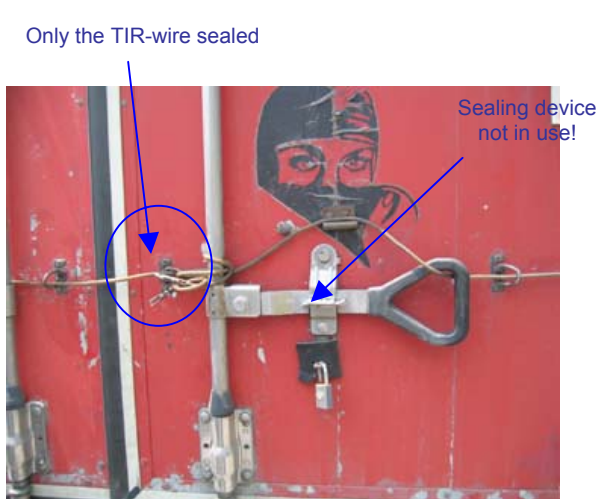

A: Pivoting device NOT sealed although the device is equipped with a specific hole for the Customs seal.



B: Pivoting device - specific hole for affixing Customs seal. Handle NOT secured.

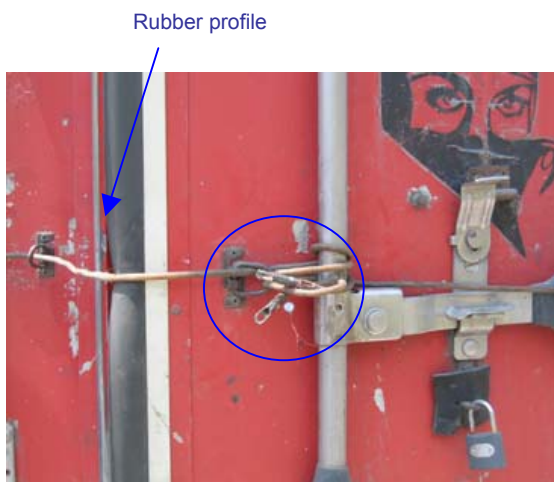

C: Pivoting device in position "OPEN". Just lift the handle and turn the locking rod - only 40 cm of extra length for TIRwire and it is possible for a person to enter the load compartment.



D: Door open - easy access.

It is very important that the location where the maneuver handle is connected to the locking rod is inspected carefully. The bolt, screw or rivet securing the handle is especially exposed to manipulation - and such manipulation is difficult to discover.

The trailer illustrated below seems to fulfil the conditions for carrying out transport under Customs seal - Pic. A. - but a close inspection determined otherwise.

The sealed TIR-wire is securing the locker for a small metal box covering the pivoting device - and it seems to be impossible to release the handle - Pic. B.

By using a wrench it was revealed that the nut for the center-bolt was not welded or riveted, and the bolt could easily be removed - Pic. C.

After the center-bolt has been removed it is possible to pull the handle the 5 cm required to be disconnected from the locking rod - Pic. D. - and now it is easy to turn the rod, disengaging the cam device and open the door.



A: Standard conditions fulfilled – apparently acceptable security and sealing.

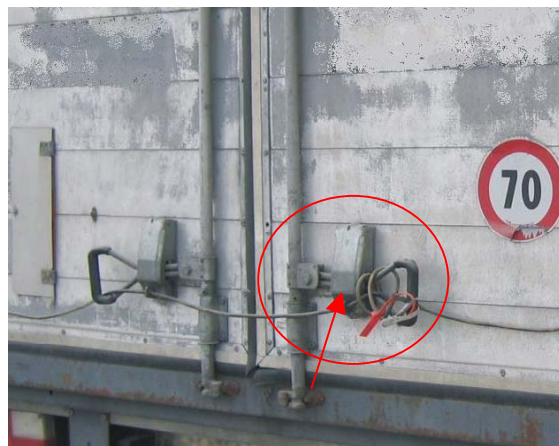

B: Locker for the metal-box covering the pivoting device secured by the sealed TIR-wire.



C: Center-bolt removed - handle slightly pulled.



D: Handle disconnected, locking rod turned - and the door is open! - And it is just as easy to put back again!

Refrigerated trailer equipped with a pivoting Customs sealing device – the same type of device being used for all locking rods. Original devices appear to be replaced.

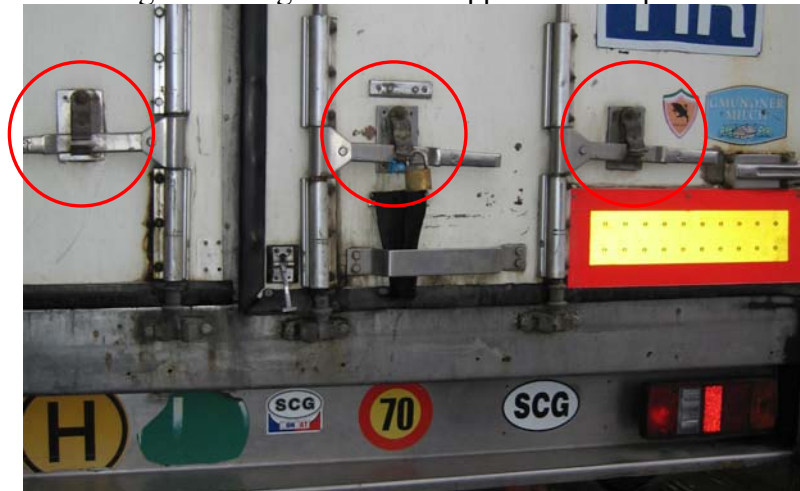

A: Original devices for all locking rods obviously replaced.



B: Pivoting Customs sealing device appear to be assembled from parts made of different metals – iron and stainless steel. Normally all parts for such devices are made of stainless steel.



C: The device illustrated clearly indicates that it has been repaired and parts replaced – or it could be adopted for easy manipulation.



D: The pivoting section secured by a normal Lag bolt meant for wood. The bolt is easily removed and the pivoting section lowered – still attached to the back plate via the string for the Customs seal. The handle is free and can now be operated and the door opened.

Refrigerated trailer equipped with a pivoting Customs sealing device – the same type of device being used for all locking rods – and they all appear to be original.



A: All pivoting devices appear to be the original.

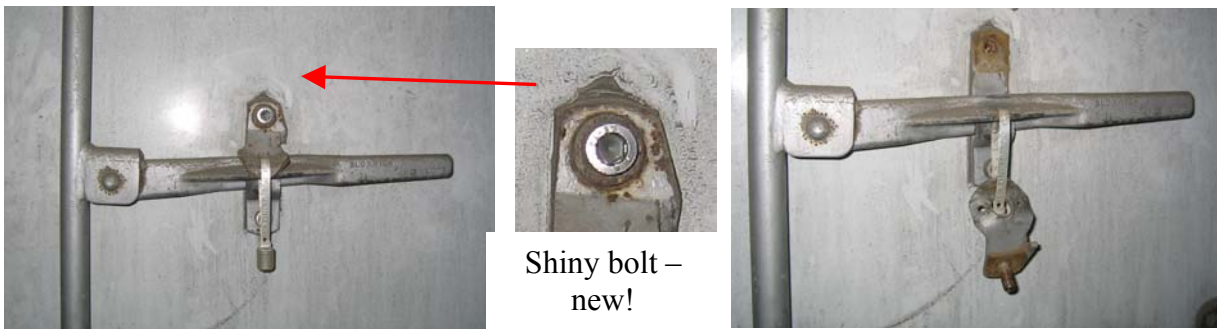

B: Pivoting Customs sealing device – pivoting section mounted with an “Allen” bolt (imbuss-bolt). The trailer equipped with 4 such pivoting devices – but the bolt for the device having the Customs seal appeared to be rather new, it was shinier compared to the other 3. The Allen bolt was removed in less than a minute, the pivoting section lowered – still attached to the handle via the Customs seal.



D: Door opened – full access to the load compartment.

Containers are normally used for transport of goods over long distances, often combined with transport overseas - i.e. transport from the far East. From a customs point of view, the sealing devices and security measures are relatively easy to inspect as containers are only having doors - Pic. A.

Still it is important to inspect the customs sealing device carefully and to make sure that a blockade for the door not being sealed is in place and that the container is approved for transport under Customs seal - Pic. B.



A: Standard 20' container placed on a trailer. Container only having doors.

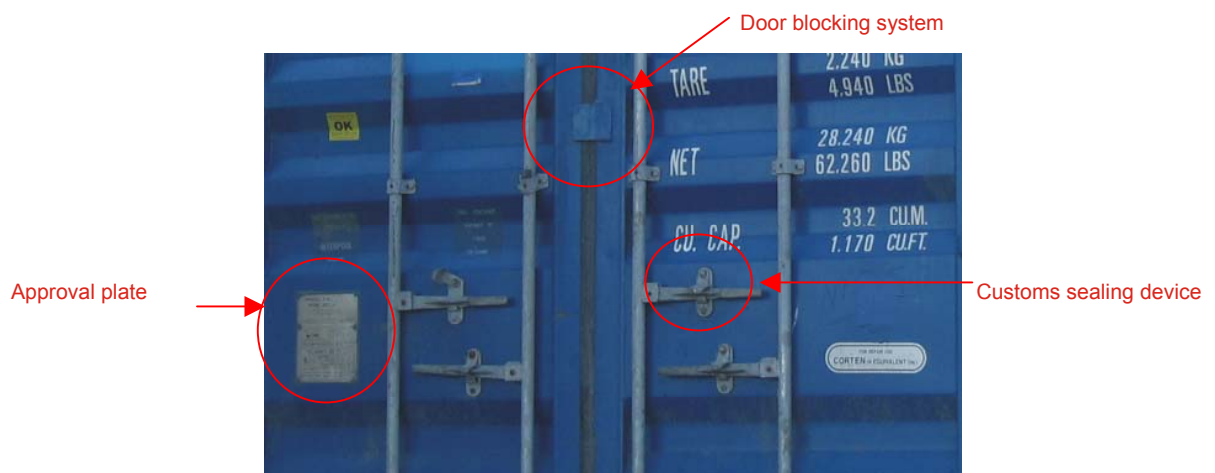

B: Customs sealing device, door blocking system and approval plate.

Examples of Customs sealing devices commonly used for containers.

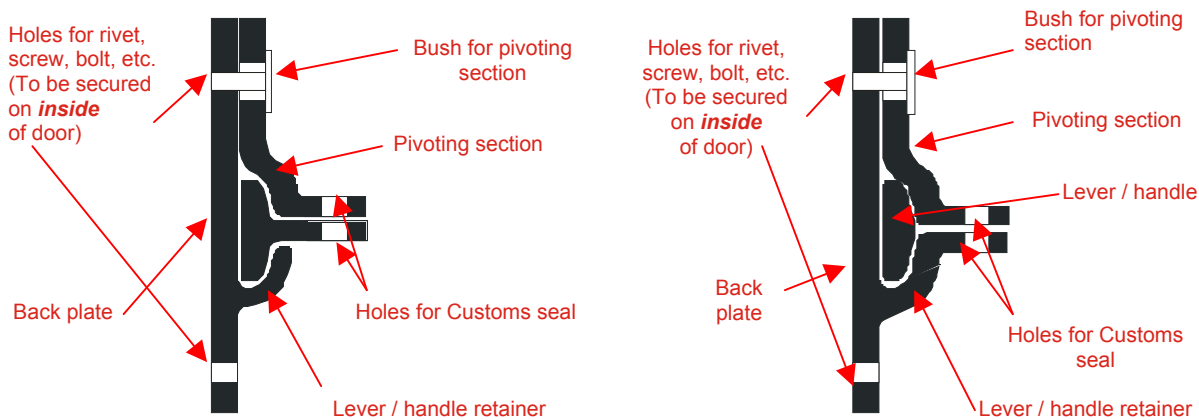

Device A.

Device B.

In particular sealing device A is prone to tampering if the above-mentioned requirements are not fulfilled. In view of their better protection against manipulation prior to affixing Customs seals, the devices given below should preferably be used by manufacturers.

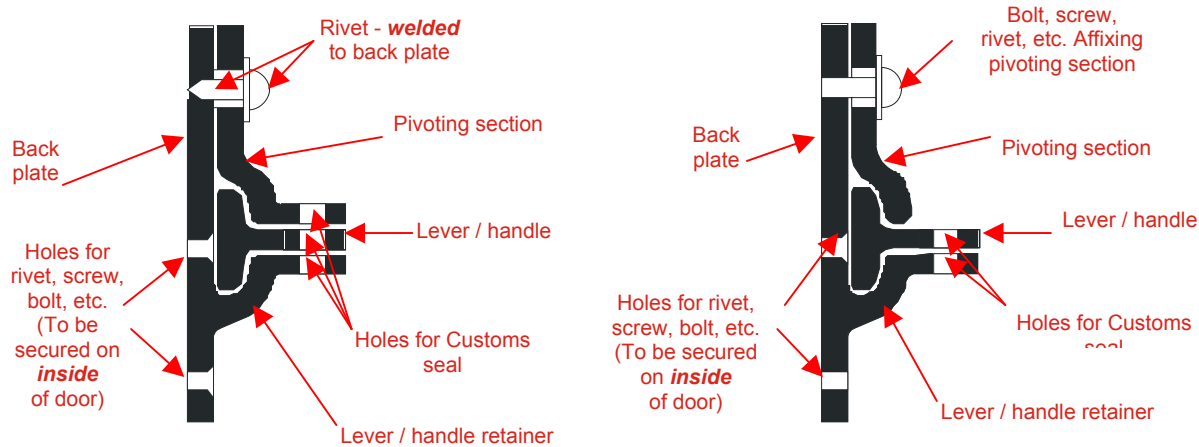

Device C.

Device D.

The sealing devices C and D may also be used for securing the doors of refrigerated and insulated containers. Where so used, the sealing devices may be affixed by means of at least two set bolts or set screws fixed into a metal tapping plate inserted behind the outer layer of the door. In such cases the heads of the set bolts or set screws must be so welded that they are completely deformed.

Illustrated below is a refrigerated container equipped with sealing device type A. The container fulfills all requirements in terms of security, as one handle is having the specified rivets securing the pivoting section. Unfortunately the Customs officer affixing the seal, made a serious mistake, as he or she sealed the non-secure device and handle - Pic. A.

In this case only one bolt needs to be removed in order to get access to the load - Pic. B and C.

When removed, the pivoting section is still connected to the handle by the customs seal, but it can all be lifted from the handle / lever retainer - Pic. D.

In this case there is full access to the load - Pic. E.

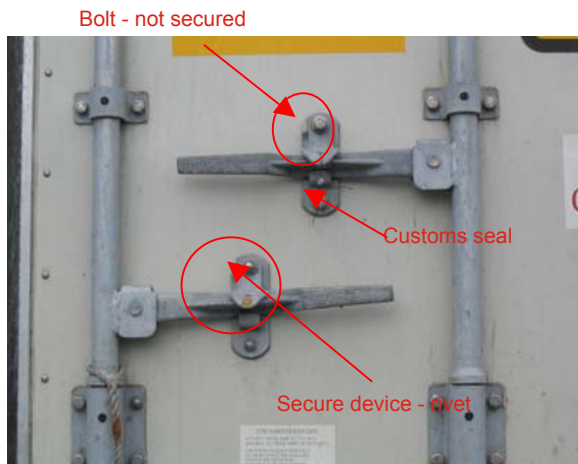

A: The non-secure device and handle sealed.



B: Only one bolt has to be removed.



C: Bolt almost removed.



D: Pivoting section and customs seal still attached to the handle.



E: Full access to load.

Illustrated below is a refrigerated container equipped with sealing device type B. The container fulfills all requirements in terms of security, as one handle is having the specified rivets securing the pivoting section. However the Customs officer sealed the non-secure device and handle - Pic. A. In this case two nuts - bolts inserted from inside - need to be unscrewed in order to remove the pivoting device *and* the back plate - Pics. B, C and D. Also in this case there is full access to the load but door only slightly opened - Pic. E.

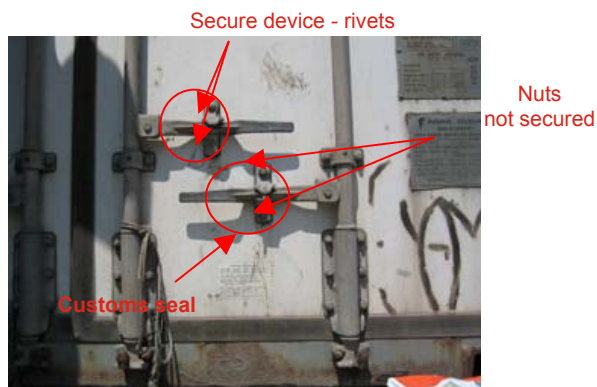

A: The non-secure device and handle sealed.

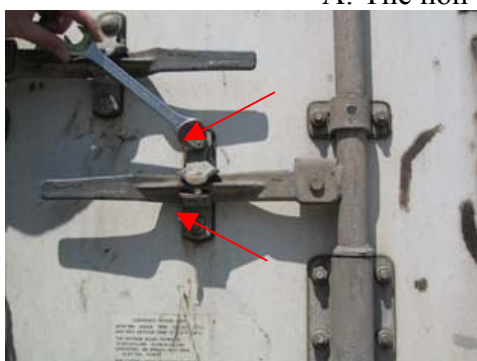

B: Unscrew both nuts.



C: Upper nut removed - pivoting device still attached to the handle and back plate.



D: Back plate and pivoting device removed.



E: Locking rods released - door slightly opened.

The entire refrigerator unit for containers can easily be replaced - although it is a heavy unit. Normally the frame for the unit is mounted to the container by many strong bolts and they are not welded.

The bolts - or the frame - are secured by seals affixed by either the manufacturer, an approved service company or by a customs authority. The same security measures apply to all other hatches which are part of the refrigerator unit - normally such hatches only provide access to air-flow channels.



A: Lower part of the frame, bolts and seal for the refrigerator unit.



B: Upper part of the frame, bolts and seal for the refrigerator unit.

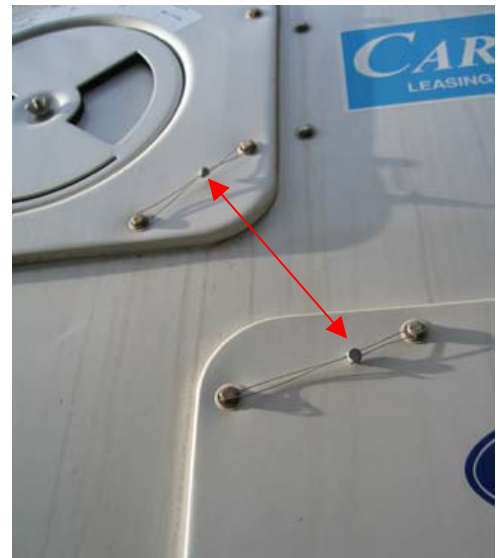

C: Two examples of sealed hatches - a part of the refrigerator unit.

3. CURTAIN SIDERS

In order to provide the best service possible - in terms of access to the load for fast and easy loading and unloading of goods - the so-called **curtain-siders** are becoming more common within the transport industry, also within the international transport.

However, from a Customs point of view, such curtain-siders have to be classified as “high risk” vehicles - as almost none of them fulfill the international TIR-standards, and the fact that the security measures are easily manipulated.

Illustrated below are the basic versions and description of curtain-siders - Pics. A and B.

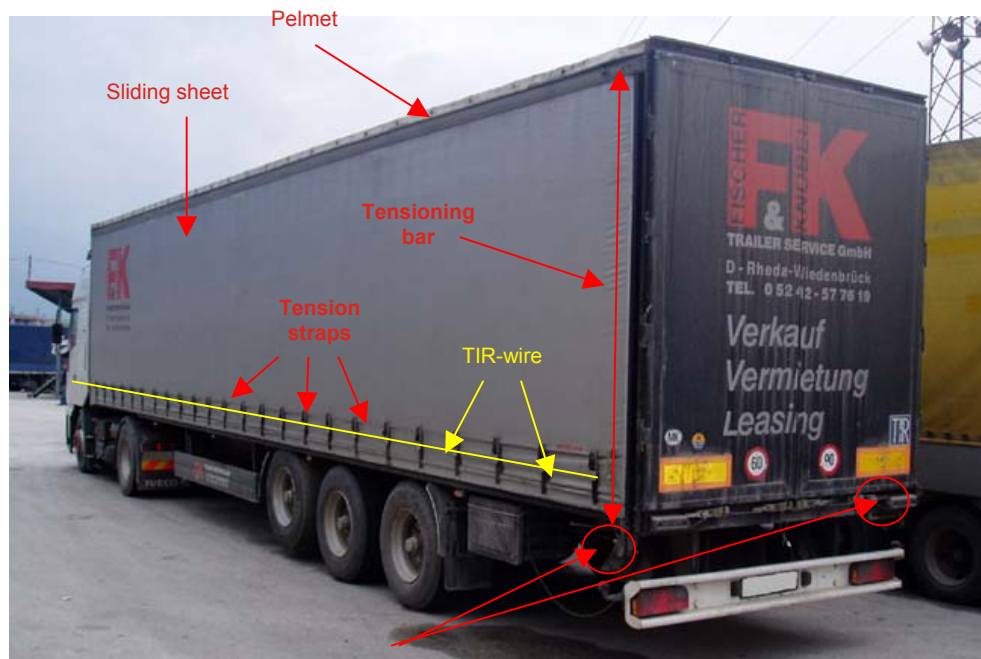

Mechanical tensioning devices
("worm-drive")

A: Curtain-sider, closed - side and rear view.



B: Curtain-sider, opened - easy access for loading/unloading.

Comparison between a “TIR compliant” trailer – and a “standard” trailer.

At first glance both trailers appear to be of the same construction, but there are fundamental technical differences between a TIR vehicle with sliding sheets and a standard vehicle with sliding sheets! Furthermore the purchase cost of the TIR version is 15% more.



1. Profiles for the rail system, sheet overlap, space between rollers - at the top of the vehicle.
2. Sheet overlap, securing the sheet - at the bottom of the vehicle.
3. Sheet tensioning device.

As illustrated below, there is a major difference in the construction of the top rail profile – normally a profile made of aluminium.

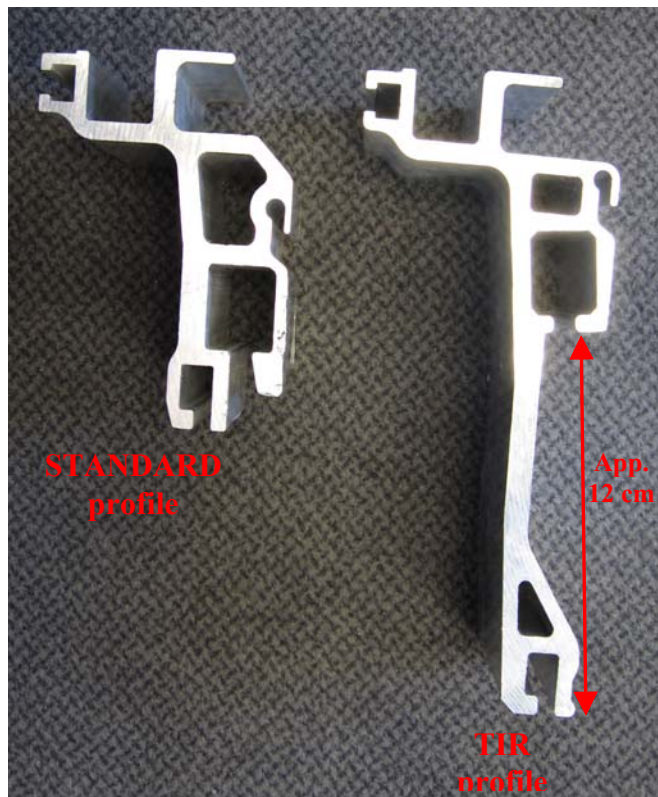

The TIR profile provides for the overlap and security at the top of the vehicle as required by the Convention – the sheet overlap shall be at least $\frac{1}{4}$ of the actual distance between the tensioning straps. The standard profile provides no overlap - and no security.



Illustrated below, the impact of the difference in distance between the rollers at the top of the vehicle.



Note the additional rollers on the TIR vehicle! – No additional rollers on the standard vehicle.



No access to the load compartment on the TIR vehicle - but good access on the standard vehicle.

Also at the bottom of the vehicle a sheet overlap is required in order to fulfil the TIR regulations – an overlap of at least 5 cm. Furthermore the horizontal opening between the sheet and the solid parts of the vehicle may not exceed 1 cm (10 mm) at any place when the load compartment is secured and sealed for Customs purposes.



The sheet on the TIR vehicle secured by reinforced eyelets, TIR rings welded to the chassis and the TIR wire passing through the rings. On the standard vehicle only the lock system for the tensioning straps are secured by the wire.

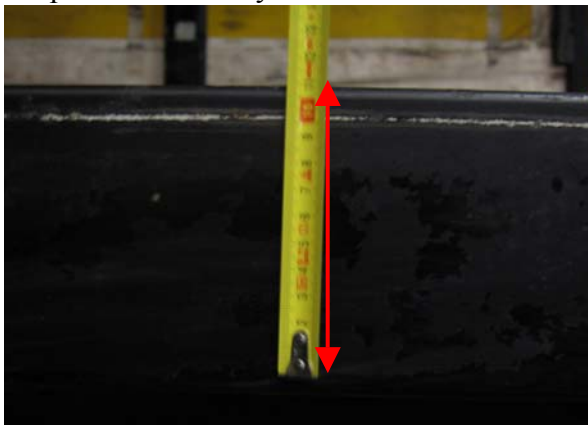

TIR vehicle: Overlap 11 cm – far more than the 5 cm required.



Standard vehicle: Overlap only 1,5 cm!



No horizontal opening!



Horizontal opening - access to the load!

There are significant differences in the construction of the sheet tensioning device.

The TIR vehicle is equipped with a device providing efficient security for Customs purposes – when the TIR wire is passing through the holes in the device; it is not possible to rotate the handle.

The device mounted on the standard vehicle does not provide any security at all – the handle can be rotated; or even removed from the shaft!

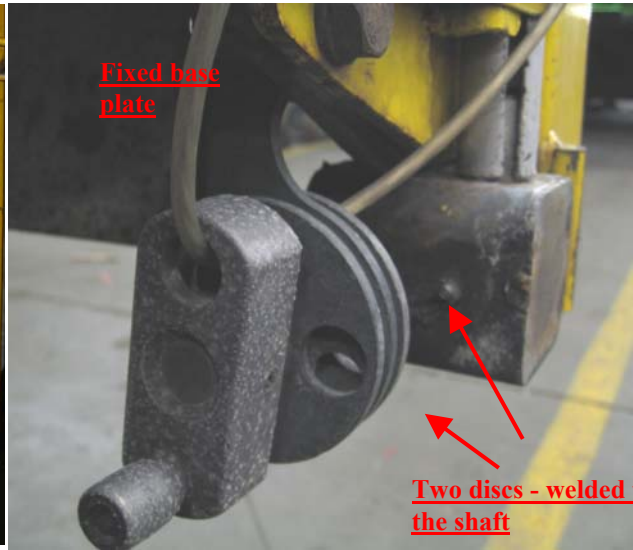

Tensioning device mounted on the TIR vehicle - providing efficient security.

Details of the security system; one fixed base plate and two discs welded to the shaft. All three having holes through which the TIR wire can pass.

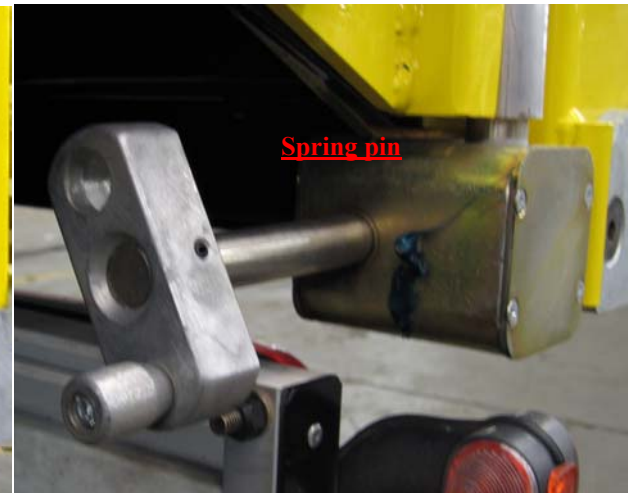

Tensioning device mounted on the STANDARD vehicle. This device provides no security at all!

Details of the system; the handle can be rotated – no blockade at all. Even if the wire is passed through the hole in the handle, it is easy to press out the spring pin and remove the handle from the shaft.

Illustrated below is one example - Pic. A - of securing the sliding sheet and two examples- Pics. B, C, D and E - of securing the tensioning device. The security measures illustrated definitely need to be in place prior to approval for international transport under customs seal.

It is worth mentioning that standard manufactured curtain-siders cannot be approved under the TIR convention - they all need additional security measures installed.



A: Sliding sheet secured by: TIR-rings welded to the chassis, sheet equipped with corresponding eyelets and finally secured by the TIR-wire.



B: Security measure: A metal plate - blocking the handle for the tensioning device (type "worm drive").



C: Security measure: The metal plate - secured by the TIR-wire blocking the handle for the tensioning device (type "worm drive").

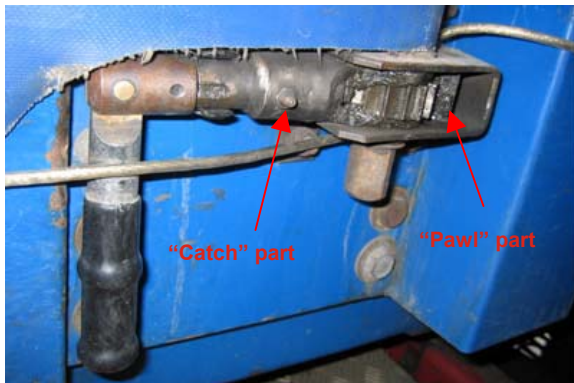

D: Tensioning device - type "ratchet".

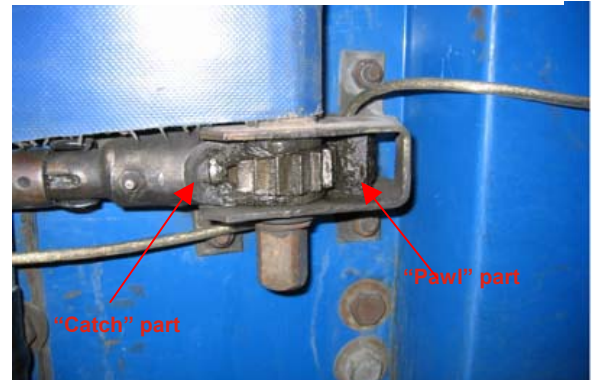

E: The pawl secured - the TIR-wire passing through special holes, blocking the pawl.

Prior to affixing Customs seals, it is good practice to make sure that all security measures in place are fully functioning and used accordingly. Far too often the security measures are not considered to be of any importance by the drivers, leaving less - or no - security of the load compartment. Sealing such vehicles as illustrated below provides absolutely no security at all.



A: Trailer equipped with tensioning device - type "catch and pawl".



B: The TIR-wire not passed through the specified holes for blocking the pawl.



C: When released, it is easy to lift the tensioning bar off the base and get access to the load.



D: Limited - but still unacceptable - access to the load.

Illustrated below an example of a modern version of a tensioning device of the type “ratchet”. This device is mass-produced and it is currently being used by a number of trailer-manufacturers. The weak point is the mounting of the pivoting plate – mounted by a rivet. This device can easily be manipulated - and even wear and tear can have a negative impact regarding the security of this device.

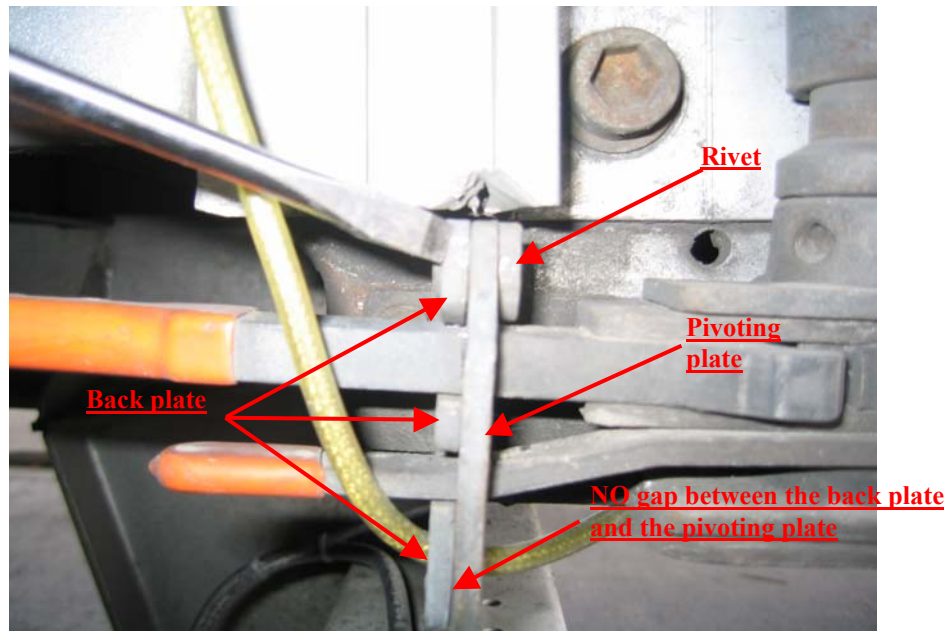

A: This device can only be considered secure and not manipulated if there is no gap between the back plate and the pivoting plate - the rivet must be pressed extremely tight.

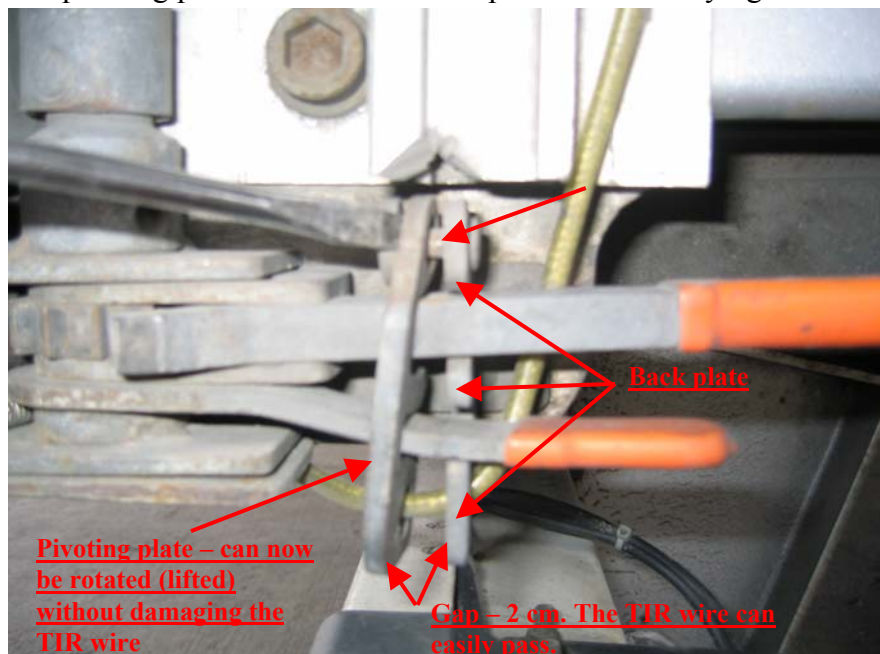

B: The device can easily be manipulated. The two most common ways of manipulation:

- 1: Manipulation of the rivet – as illustrated.
- 2: The pivoting plate can be slightly bent in order to achieve the gap between the plates less than 1 cm required for the TIR-wire to pass.

The device illustrated below does obviously not provide any security at all – most likely the rivet is manipulated.

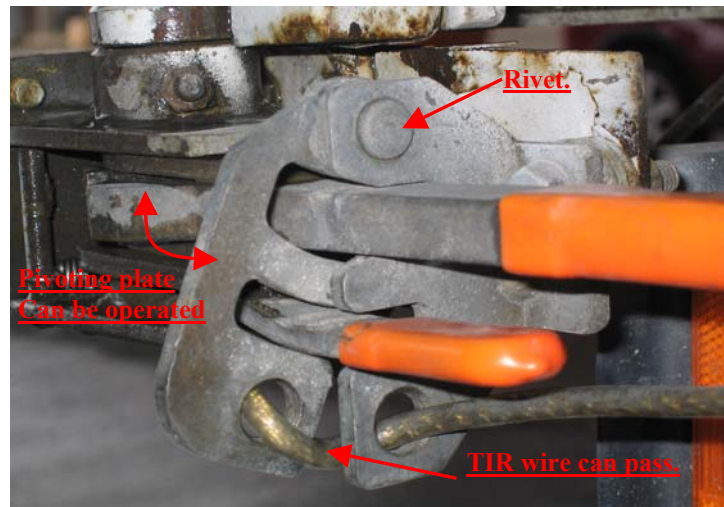

A: Rivet manipulated – or it is not fully pressed, a significant gap between the back plate and the pivoting plate. The pivoting plate can be operated – the TIR wire can pass without being damaged.



B: The device can be operated if additional length of the TIR wire can be found and located next to the handles – only 15 cm is required. On this trailer 35-40 cm were found.



C: The additional 35-40 cm made it possible to place the wire behind the handles – the device is now ready to be operated as if there was no wire at all.



D: Tensioning bar and sheet released – access to the load compartment.

Illustrated below an example of a modern version of a tensioning device of the type “ratchet”. This device is mass-produced and it is currently being used by a number of trailer-manufacturers. The weak point is the gap between the handles and gap between the main handle and the base plate. Furthermore it is easy to disengage the spring-loaded pawl.

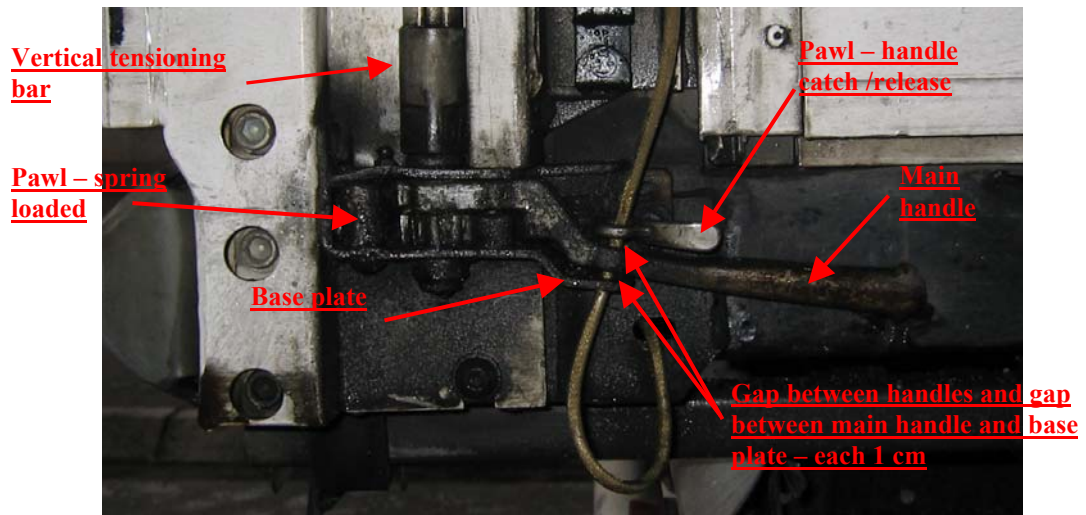

A: This device can not be considered secure. The gap between the handles and the gap between the handles and base plate is each approximately 1 cm – thickness of the TIR wire is only 7-8 mm. Note the additional length of the TIR wire – approximately 25 cm!

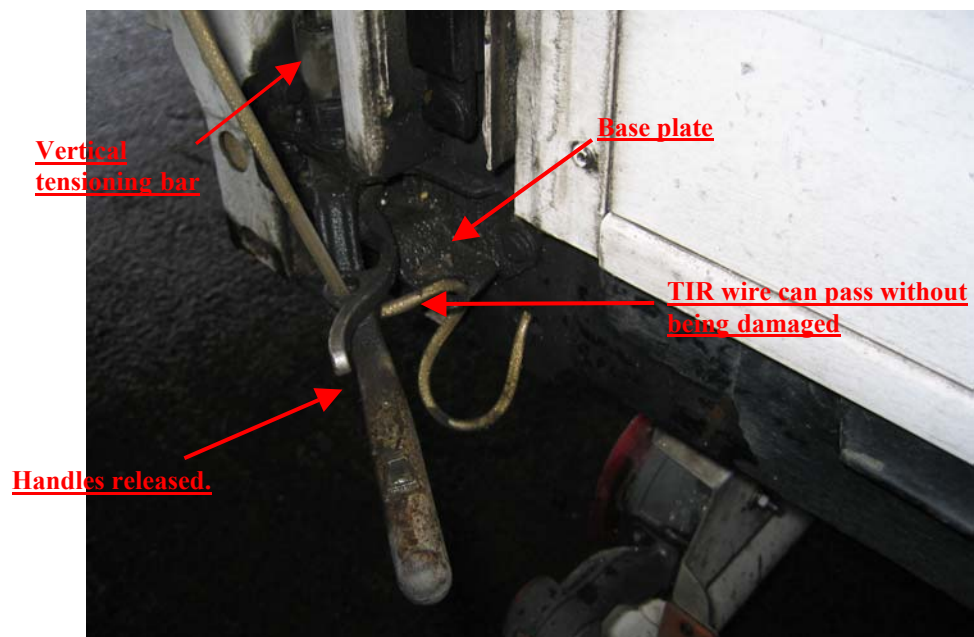

B: The gap between the base-plate and the main handle – 1 cm - allows the wire to be squeezed and pass between the handle and base-plate without being damaged. The length of the TIR wire makes it possible to disengage and operate the tensioning device, release tension on the sheet and lift the tensioning bar off its base. Only 10-15 cm of TIR wire needs to be placed next to the device in order to disengage the system.



C: This picture illustrates how to disengage the spring loaded pawl. This pawl and the cam wheel creates a ratchet system and it is the brake for the tensioning bar. By the use of a "LEATHERMAN" multi-tool or a screw driver it is easy to disengage the system.



D: Trailer opened – providing access to the load.

Illustrated below is a curtain-side trailer equipped with tensioning devices of the “worm drive” type. The handle for operating the drive has the shape of a small wheel, but in this case the handle was not secured prior to sealing the vehicle.

This type of handle and drive is very difficult to secure. In most cases the TIR-wire will be passed through the handle, providing some security, but if the TIR-wire is just 50 cm longer than required it is easy to operate the handle, release the system and lift the tensioning bar off the base. Furthermore the handle itself is often just fixed to the axle by a bolt or screw - whereas it should be welded. Special attention should also be paid to the tension straps - if not tightened properly they can be released from the grip at the chassis frame. Such trucks or trailers cannot be approved under the TIR convention!



A: Handle not secured - TIR-wire not passed through the handle.



B: System released - tensioning bar lifted off the base - sheet opened 50 cm.



C: Although providing no security at all, this trailer has wrongly obtained TIR approval.



D: Customs seal still intact.

Illustrated below is a trailer which on first observation seems to be secure, as the TIR-wire is passing through the handle for the “worm drive”.

However the long TIR-wire - Pics. A and B - makes it possible to activate (turn) the handle -and the wire will just get twisted - Pics. D and E - meanwhile the tension bar gets released.

When tension is diminished it is easy to lift the bar off the base and gain access to the load compartment.



A: TIR-wire is far too long at the point of sealing.



B: Even additional length (3 meters) along the side.



C: Handle seems to be secured - wire passing through.



D: But this long wire will just get twisted when the handle is turned and the tension bar can be lifted off the base.



E: The handle and the twisted wire.



F: Tension bar released - access to the load.

Illustrated below is a trailer equipped with a security device installed by the manufacturer. Unfortunately such devices are very easy to bypass - just 25 cm of TIR-wire needed. Also in this case the vehicle has been approved for carrying out transport under the TIR convention.

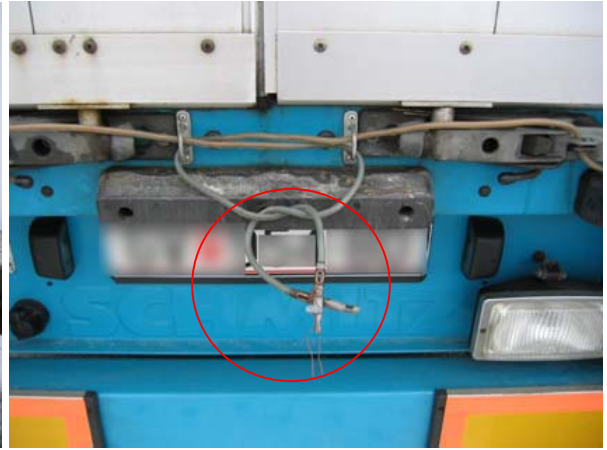

A: Security measure - TIR-ring and corresponding eyelet in the sheet.

B: Additional wire - just 25 cm.

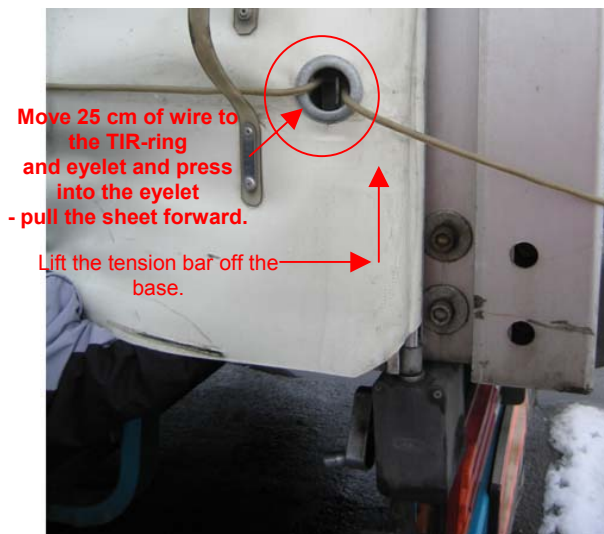

C: 25cm of wire moved, and a loop pressed into the eyelet. Sheet and eyelet pulled forward - free of the TIR-ring. Now one just has to rotate the handle - release tension and lift the tension bar off the base.

D: Limited - but unacceptable access to the load.
Note the TIR approval.

A special type of curtain-sider is equipped with the so-called “Quick release” system. The “Quick release” system is operated by a single movement of a handle. When closed the handle is retained on a hook (base) welded to the chassis - Pic. A.

In order to release the system, just pull or push the handle and lift it off the base.

This system is most frequently being used on trucks and trailers having sideboards with TIR-rings and the sheet having corresponding eyelets, the sliding sheet then being secured by the TIR-wire - no tensioning straps. Always make sure that TIR-rings, eyelets and the wire fulfill requirements. Pic. B shows an example of TIR-rings not being used accordingly and TIR-wire wrongly passed - in such cases it is easy to get access to the load - Pic. C.

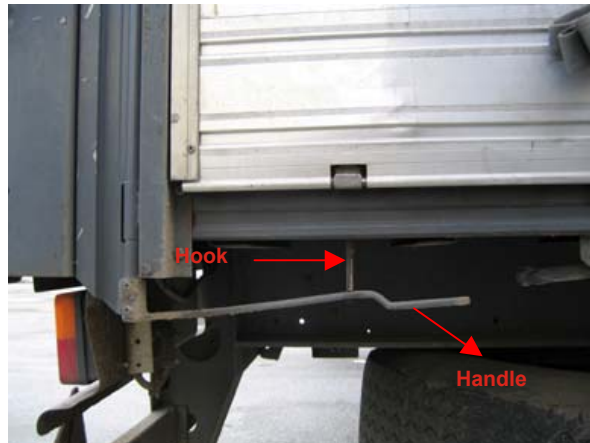

A: “Quick release” system, handle and hook (base) - a system very easy to operate.



B: TIR-wire wrongly passed and TIR-rings not being used.



C: Access to the load - it is possible to slide the sheet 80 cm.

Illustrated below an example of a system – “Quick release” - used by the company SAMRO (France). The weak point is the gap between the eyelets. Furthermore it is easy to disengage the spring-loaded catch.

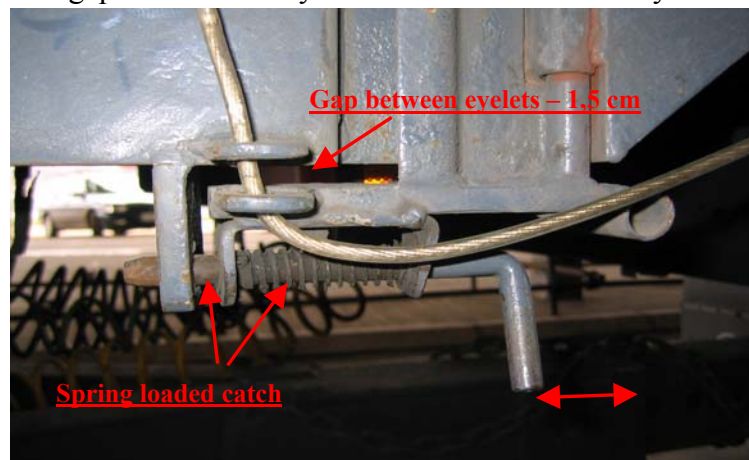

A: Spring loaded catch – a so-called “Quick release” system located on each corner of the truck and trailer – in total 8 pieces. The TIR wire is meant to secure the device, but as illustrated the gap between the eyelets is significant.



B: The system is very simple to operate, just pull the handle for the catch and slightly rotate the device.

C: The significant gap will allow the TIR wire to pass and it is now possible to release the aluminium profile and the sheet.



Note the TIR approval - truck and trailer opened in less than 1 minute!

Recently invented “Quick release” system – trailer manufactured by the Shmitz Company. It is operated by the movement of a single handle. When closed the handle is kept in place (locked) by a pivoting lock tab. It is worth noticing that mounting of the lock tab to the chassis – frame is normally made by a nut – not welded and secured. It will only take a minute to release the lock tab, turn the handle and lift the tensioning bar off its base.

Pics. A - D

Tensioning bar

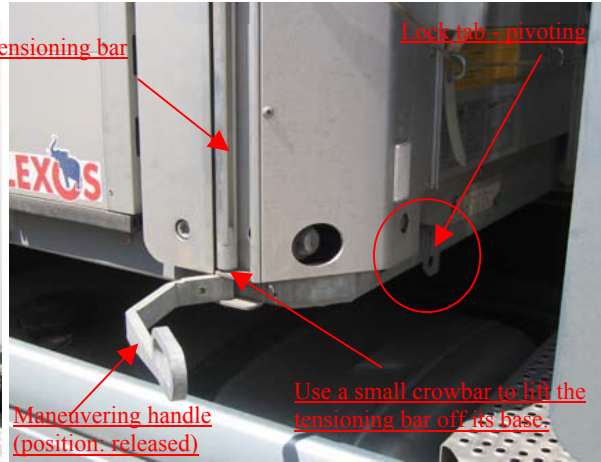

A: The system in position „LOCKED“. To release: Press the maneuvering handle; rotate the lock tab to horizontal position; now the handle is released and can be pulled.

B: The system in position „OPEN“. The maneuvering handle pulled; tension of the sheet released; it is now possible to lift the tensioning bar off its base.



C: The tensioning bar lifted off its base. The very first TIR-ring mounted on the sideboard is blocking the tensioning bar and sheet to be moved more than 25 cm, but there is still good access to the load compartment.

D: The tensioning bar lifted off its base. Although the TIR-ring blocking the tensioning bar, the upper part of the sheet can be moved approximately 60 cm, which provides a significant opening.

4. TANKERS

Correct and efficient sealing of tankers is often very complicated as many technical details need to be closely inspected. Normally seals are affixed at: The manholes, the end cover for the discharging pipe and the valve compartment.

It is good practice especially to inspect the hinges, the locking system and the device for affixing Customs seals at the manholes, as these points are easy to manipulate.

Standard points for affixing Customs seals illustrated below - Pic. A and B.

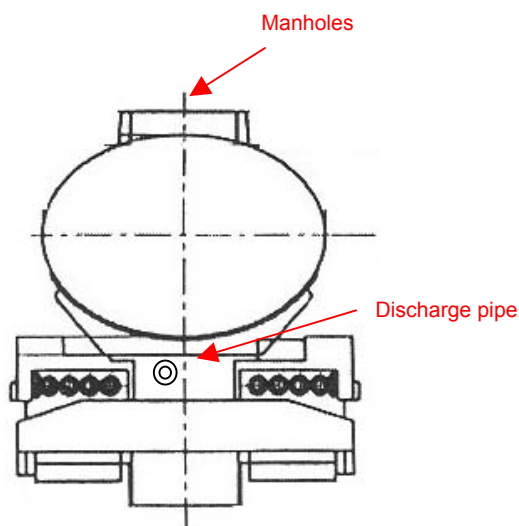

A: Rear view of a tanker.

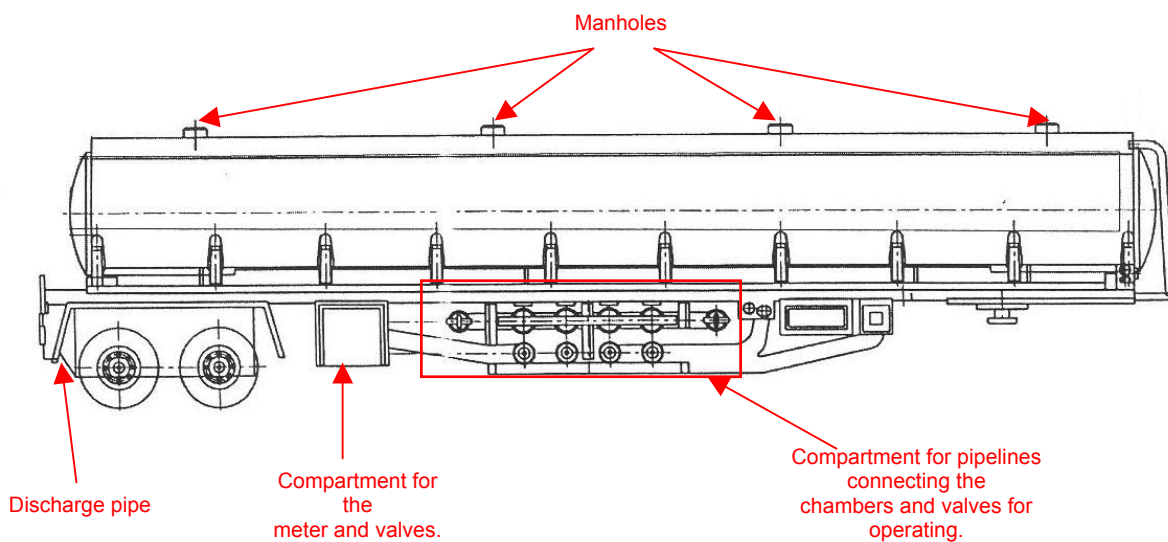

B: Side view of a tanker.

Illustrated below is a typical example of how easy it is to get access to the chamber of a tanker. Several technical details do not fulfill international standards: Hinges not secured, center bolt and handle not secured and the sealing device being “homemade”.

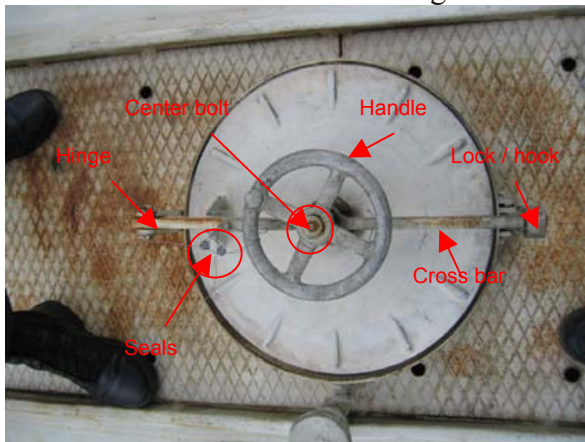

A: Typical manhole cover, locking system and method of affixing the Customs seal.

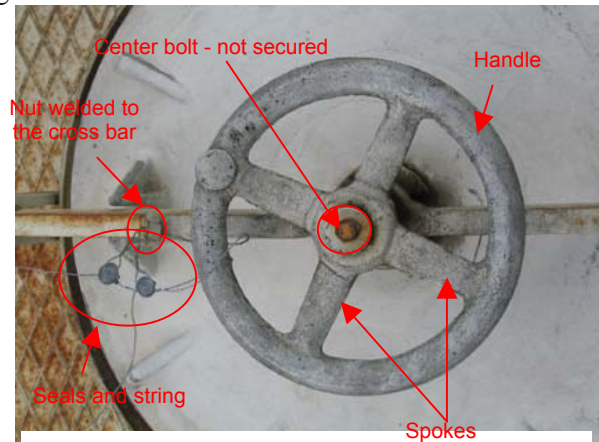

B: Sealing device: A nut welded to the cross bar, the string for affixing the seal just passed through the nut and the space between the spokes at the handle.



C: Center bolt removed - handle released from the main axle.

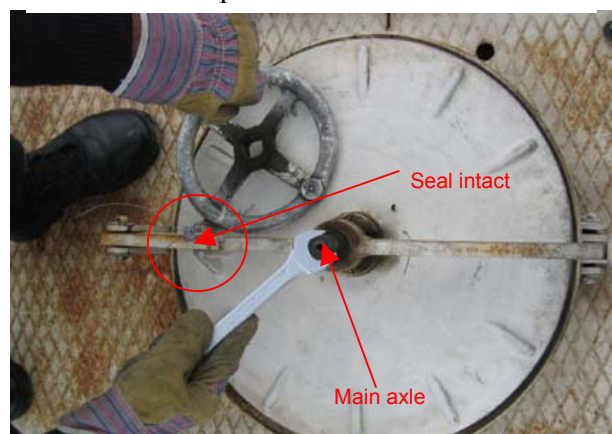

D: Release the pressure on the cross bar by turning the main axle - and remove the lock.



E: Manhole open - access to the chamber.

Illustrated below is the same typical manhole cover as shown on the previous page. Several technical details not up to international standards: Hinges, handle and lock not secured, no sealing device installed. Furthermore a mistake made by the officer.

In this case the handle is sealed with two Customs seals. As there is no specific sealing device installed, the strings for affixing the seals have been passed under the cross bar and then up between the spokes - each seal affixed on top of a spoke.

However the officer sealing this tanker made a serious mistake - both strings for affixing the seals are far too long, and the seals not affixed as tightly as possible.

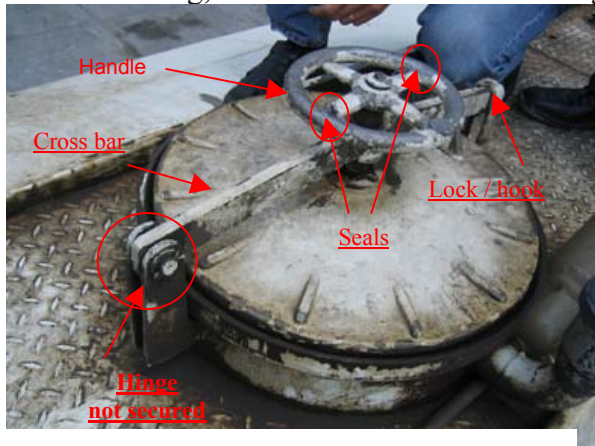

A: Typical manhole cover and locking system.

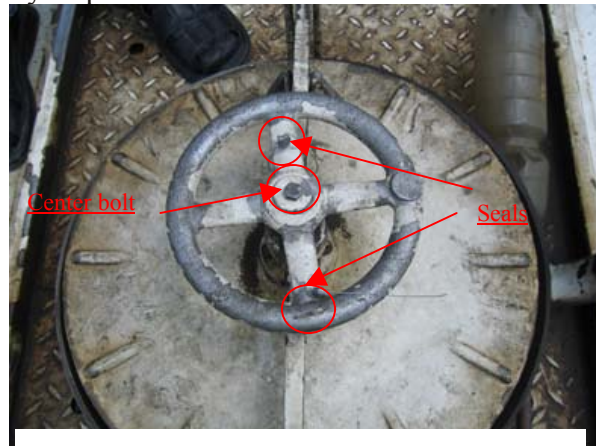

B: Two Customs seals, string passed under the cross bar and then up.



C: Center bolt almost off.



D: Handle removed from the main axle.



E: Easy to release the pressure on the cross bar - and remove the lock.

The sealing device for the discharge pipe is often exposed to manipulation and it is good practice to inspect this device carefully.

Illustrated below is a typical way of manipulating this device.

The string for the seal is passed through a hole in the end cover and a hole in a metal plate mounted to flanges at the valve. In this case the metal plate is only kept in place by a single - non secured - bolt, and therefore easy to dismantle.

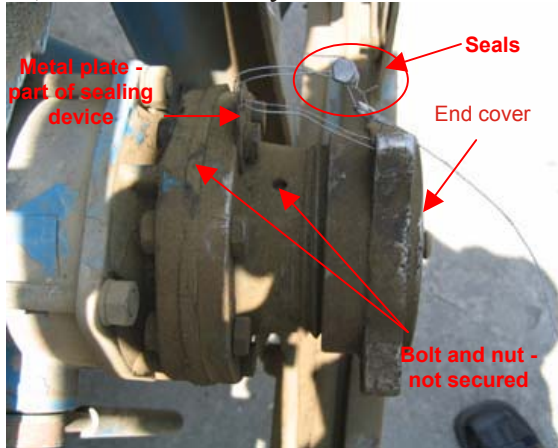

A: End cover the discharging pipe - details.

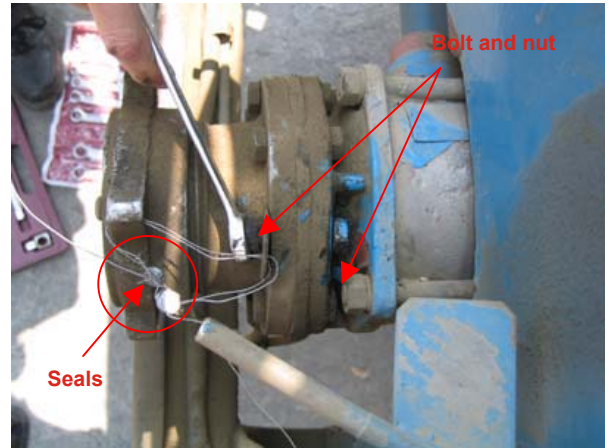

B: Metal plate only kept in place by the bolt - easy to dismantle.

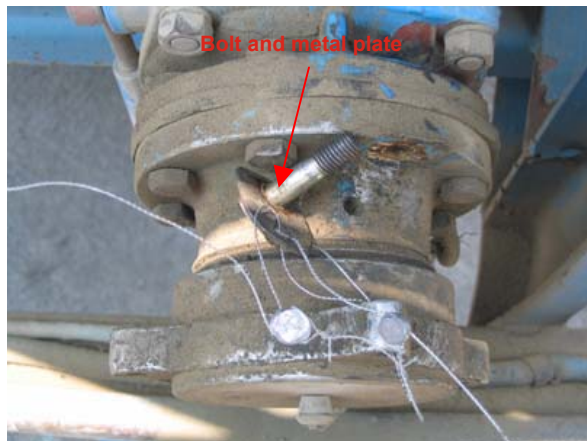

C: Bolt and plate dismantled - now only attached to the end cover by the strings and seals.



D: End cover removed - now it is possible to discharge - just activate the valve.



E: View of the discharge pipe, end cover, seals and metal plate.

Illustrated below is a tanker equipped with a compartment for pipelines connecting the chambers and valves for operating. Such compartments are normally made of metal plates and simple to secure by sealing. However, the sealing device and the hinges should always be inspected.



A: Tanker equipped with a special compartment for pipelines and valves.



B: Hatch for the compartment - handle, locks and the customs seal.



C: Sealing device and the customs seal.



D: Inspect the hinges. The pin for this hinge has been replaced by a piece of rusty iron bar - not secure at all.

5. VANS AND LITTLE TRUCKS

Vans of different load capacity are becoming more and more common within international transport. However manufacturers of such vehicles very seldom equip these vehicles with any sealing or security measures - and installation of such measures are to be made by the owner. It is therefore good practice to inspect: Interior trim between the cabin and load compartment (cargo wall), hinges, windows (if any) and the sealing device.



A: Load compartment.



B: Interior trim (cargo wall).



C: Interior trim - with window.



D: Standard Van - load capacity app. 1.500 kg.

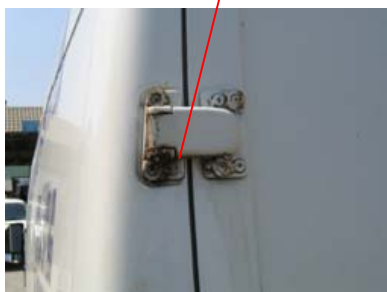

E: Hinge - secured by welding.



F: Rear door - window secured by metal gauze.



G: Sealing device - secure, welded.

Illustrated below are some examples of sealing devices which do not meet international standard - and should not be accepted.

Blind rivets do not provide any security at all as they are inserted from outside and are easy to remove and replace - Pics. A and B.

It is obvious that homemade sealing devices, only fixed with standard screws, cannot be accepted - Pics. C and D.

Hinge pins and bearings should always be secured by welding - if not secured they are easy to press out and remove - Pic. E.

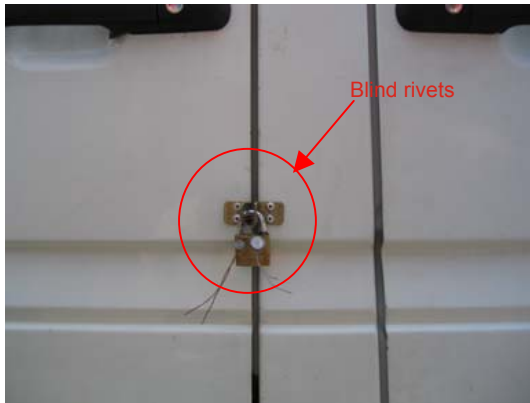

A: Sealing device - sliding side door – only fixed with blind rivets.



B: Sealing device - rear doors – only fixed with blind rivets.



C: Sealing device - homemade - the two plastic bits fixed with standard screws.



D: Only 4 screws need to be removed - and the device is ineffective.

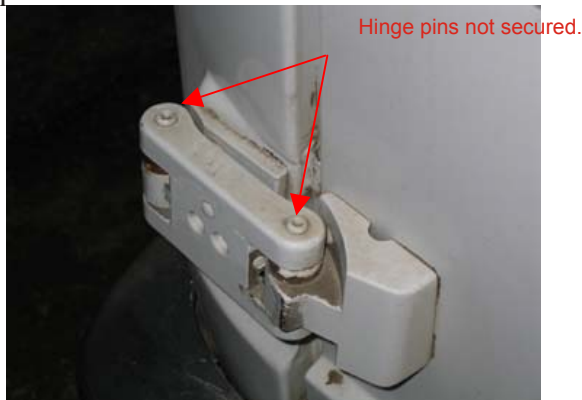

E: Hinge - rear door hinge - pins not secured, easy to press out.

As illustrated below, not only hinges and sealing devices need to be secured, but also windows. Security of windows can be made either by replacing the window with a metal plate being welded - or by installing a wire gauze (a net made of strong metal wire).

It is most common to install a wire gauze - Pic. A.

Non-secured windows fitted on doors or the interior trim between the cabin and the load compartment should not be accepted - Pic. B and C.

Adhesive plastic foil - as shown on Pic. D and E - do not provide any security in terms of access to the load, the window can still be removed. Such foil only prevents visibility.



A: Rear door - window secured by metal gauze.



B: Rear door - window not secured.



C: Window between the cabin and the load compartment - window not secured.



D: Rear door - window not secured – only adhesive plastic foil to diminish visibility.



E: Detail - adhesive plastic foil.

Occasionally small trucks only designed for domestic transport - i.e. designed for mail or parcel delivery service - can be found to carrying out international transport. In most cases such vehicles do not meet the international standards - and should not be accepted for transport under customs seal. Illustrated below is the interior of a vehicle originally designed for a courier company - United Parcel Service (UPS) - now owned by a locally registered company and carrying out international transport. It is obvious that such vehicles cannot be accepted without proper security measures being installed.



A: Sliding door between the cabin and the load compartment.

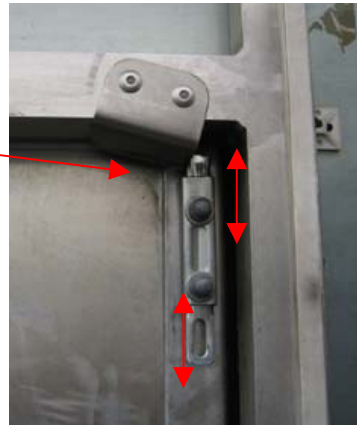

B: Lock system, a spring loaded catch, easy to operate. Pull down and lock released.

It is easy to access the lock via the hole - all that is required is a thin metal bar shaped to fit and grip the catch.

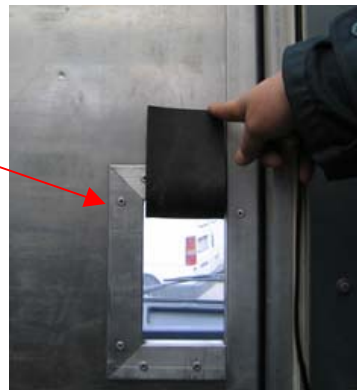

C: Access from the cabin, the hole just covered by a plate made of soft rubber.

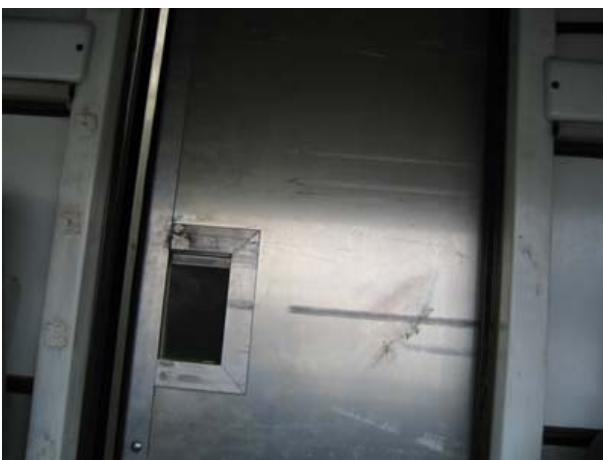

D: Sliding door - view from the cabin.



E: Sliding door open – view from the load compartment.

Small trucks equipped with a hydraulic ramp are often seen carrying out international transport. Some of those trucks are equipped with a ramp that only partly covers the rear end. The part not covered by the ramp is often a top-hinged wooden plate - and this plate is secured by the ramp overlapping the plate when the ramp is closed. It is good practice to inspect the hinges and the sealing device - and when affixing seals, leave the string as short as possible.



A: Rear view of a small truck with hydraulic ramp.



B: Seal and sealing device.
Note the long string - leaving a loop of approximately 6 cm.



C: Non-secure hinge for the wooden plate. The pin is just a standard bolt with a dome-nut, not welded.



D: Hydraulic system activated – the ramp opened as much as possible without breaking the seal.

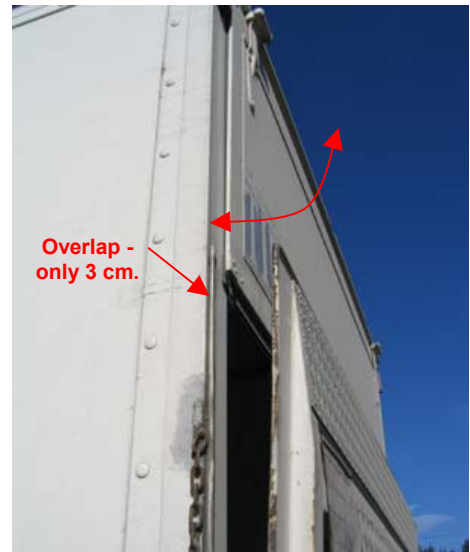

E: When the ramp is opened it is often possible to swing (lift) the wooden plate and get access to the load.
