



Economic and Social Council

Distr.: General
21 November 2014

Original: English

Economic Commission for Europe

Administrative Committee for the TIR Convention, 1975

Sixtieth session

Geneva, 5 February 2015

Item 5 (e) of the provisional agenda

Revision of the Convention:

Amendment proposals to the Convention: Vehicles with sliding sheets

Amendment proposals to the Convention: Vehicles with sliding sheets

Note by the secretariat

1. At its 138th session, the Working Party on Customs Questions affecting Transport (WP.30) considered document ECE/TRANS/WP.30/2012/6/Rev.6, prepared by the secretariat in close collaboration with the International Association of the Body and Trailer Building Industry (CLCCR) containing amendment proposals for a new design of a vehicle and container to the TIR Convention. The Working Party adopted the document, subject to improvement of the reference made in Sketch 9 to Sketch 9.4. The secretariat was requested to transmit the proposal to the TIR Administrative Committee (AC.2) in the three working languages for consideration and, possibly, adoption (ECE/TRANS/WP.30/276, para. 17).

2. This document contains, in Annex, the precise wording of the proposals to amend Annex 2 and 7 of the Convention, in the presentation format prescribed by the United Nations and as revised in accordance with the above mentioned instructions from WP.30 at its 138th session. In addition, the Annex is now preceded by a rationale, as requested by the Committee, at its forty-ninth session (ECE/TRANS/WP.30/AC.2/101, para. 22).

GE.14-22507 (E)



* 1 4 2 2 5 0 7 *

Please recycle 



Annex

Amendment proposals for adoption by the Administrative Committee for the TIR Convention

The Administrative Committee,

Recognizing that in order that goods carried under the TIR transit procedure may travel with minimum interference “en route” and yet offer maximum safeguards to customs administrations it is necessary that goods travel in customs secure vehicles or containers,

Understanding that vehicles and containers with a sheeted sliding roof are a new transport technique improving the effectiveness and efficiency of road transport,

Convinced that the introduction of a new design of vehicles and containers with a sheeted sliding roof or sliding sheets is customs secure and could be incorporated into Annexes 2 and 7 of the TIR convention,

Has adopted the following amendments in accordance with the provisions of Article 60 of the Convention:

Annex 2, Article 4, paragraph 2, (i)

For the existing text substitute(i) The sliding sheets, floor, doors and all other constituent parts of the load compartment shall be assembled either by means of devices which cannot be removed and replaced from the outside without leaving obvious traces, or by such methods as will produce a structure which cannot be modified without leaving obvious traces.

Annex 2, Article 4, paragraph 2, (iii)

For the existing text substitute

(iii) The sliding sheet guidance, sliding sheet tension devices and other movable parts shall be assembled in such a way that when closed, and Customs sealed, doors and other movable parts cannot be opened or closed from the outside without leaving obvious traces. The sliding sheet guidance, sliding sheet tension devices and other movable parts shall be assembled in such a way that it is impossible to gain access to the load compartment without leaving obvious traces once the closing devices have been secured. An example of such a system of construction is given in sketch No. 9 appended to these Regulations.

Annex 2, new Article 5

After the modified Article 4 insert

Article 5

Vehicles with a sheeted sliding roof

1. Where applicable, the provisions of Articles 1, 2, 3 and 4 of these Regulations shall apply to vehicles with a sheeted sliding roof. In addition, these vehicles shall conform to the provisions of this Article.
2. The sheeted sliding roof shall fulfil the requirements set out in (i) to (iii) below.

- (i) The sheeted sliding roof shall be assembled either by means of devices which cannot be removed and replaced from the outside without leaving obvious traces, or by such methods as will produce a structure which cannot be modified without leaving obvious traces.
- (ii) The sliding roof sheet shall overlap with the solid part of the roof at the front side of the load compartment, so that the roof sheet cannot be pulled over the top edge of the upper cantrail. In the length of the load compartment, at both sides, in the hem of the roof sheet, a pre-stressed steel cable shall be inserted in such a way that it cannot be removed and re-inserted without leaving obvious traces. The roof sheet shall be secured to the sliding carriage in such a way that it cannot be removed and re-secured without leaving obvious traces.
- (iii) The sliding roof guidance, the sliding roof tension devices and other movable parts shall be assembled in such a way that when closed, and Customs sealed, doors, roof and other movable parts cannot be opened or closed from the outside without leaving obvious traces. The sliding roof guidance, sliding roof tension devices and other movable parts shall be assembled in such a way that it is impossible to gain access to the load compartment without leaving obvious traces once the closing devices have been secured.

An example of a possible system of construction is shown in sketch No.10, appended to these Regulations.

Annex 2, Sketch No. 9

For the existing Sketch No. 9 *substitute*

Sketch No. 9

EXAMPLE OF A CONSTRUCTION OF A VEHICLE WITH SLIDING SHEETS

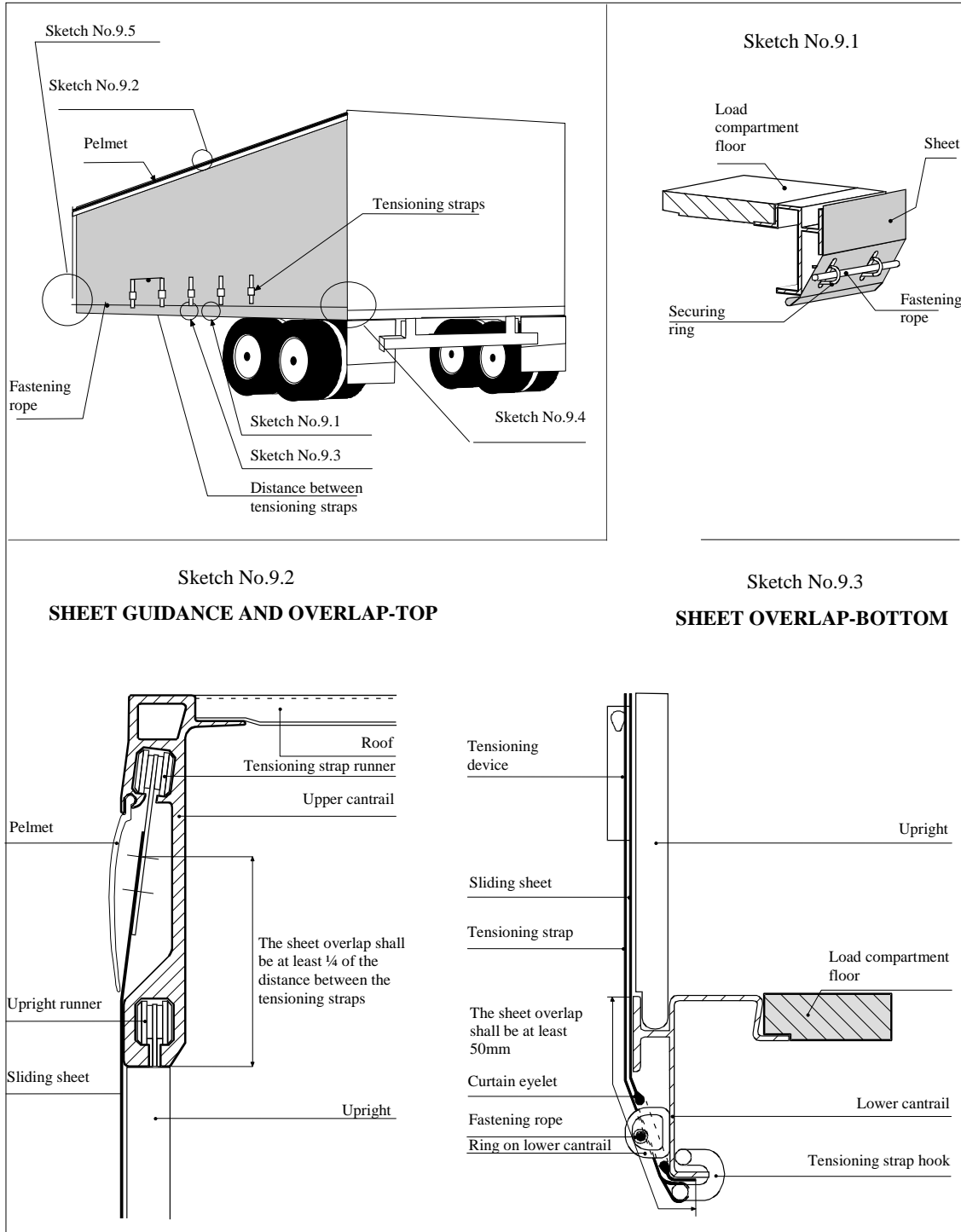

Sketch No. 9 continued

Sketch No. 9.4

To tighten the sliding sheets in the horizontal direction, a ratchet gear is used (normally at the rear end of the vehicle). This sketch shows two examples, (a) and (b), of how the ratchet or gearbox may be secured.

(a) Ratchet securing

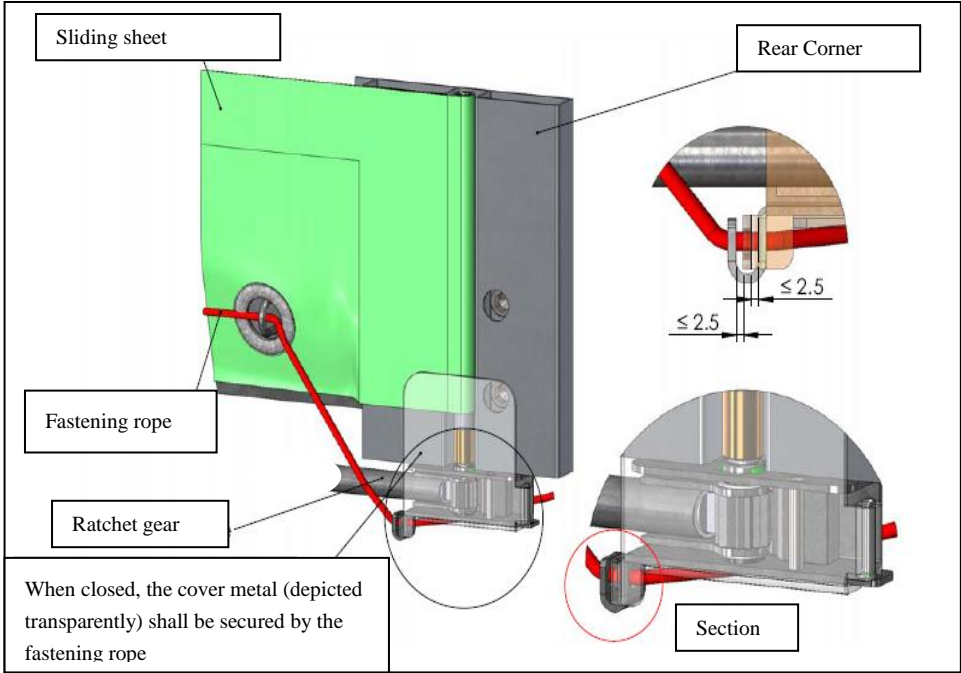

(b) Gearbox securing

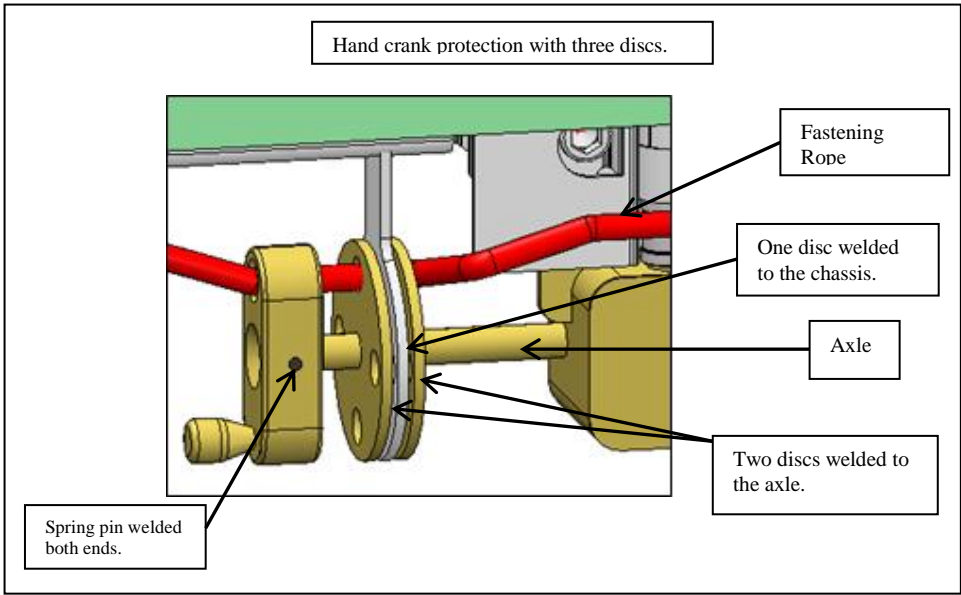

Sketch No. 9 continued

Sketch No. 9.5

To fix the sliding sheet on the other side (normally the front of the vehicle), the following systems, (a) or (b), may be used.

(a) Cover metal

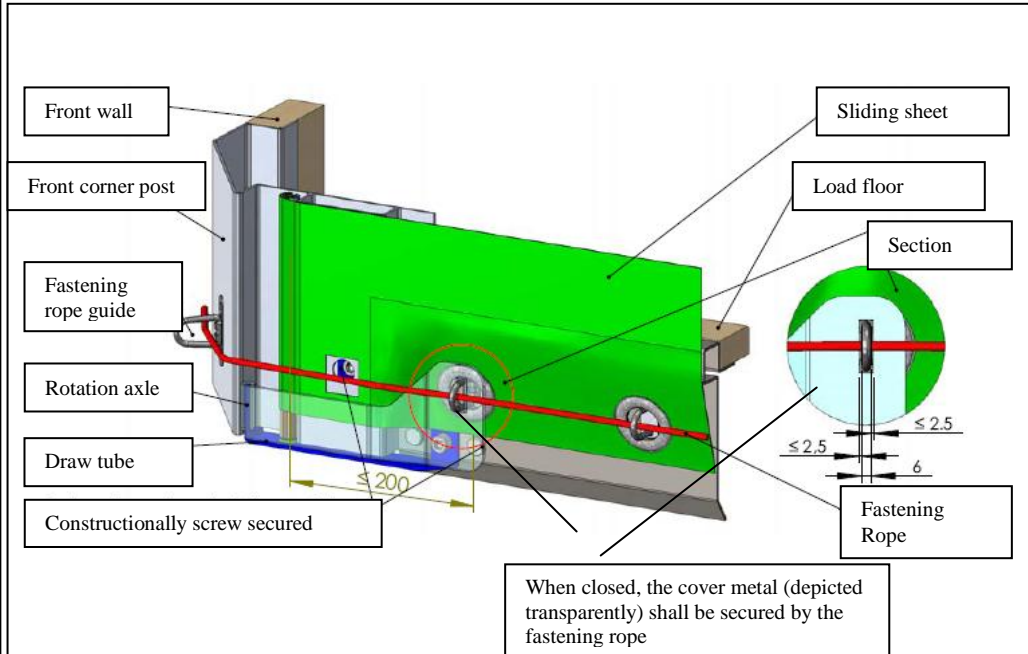

(b) Narrow oval eyelet, anti-lifting system for the tensioning tube

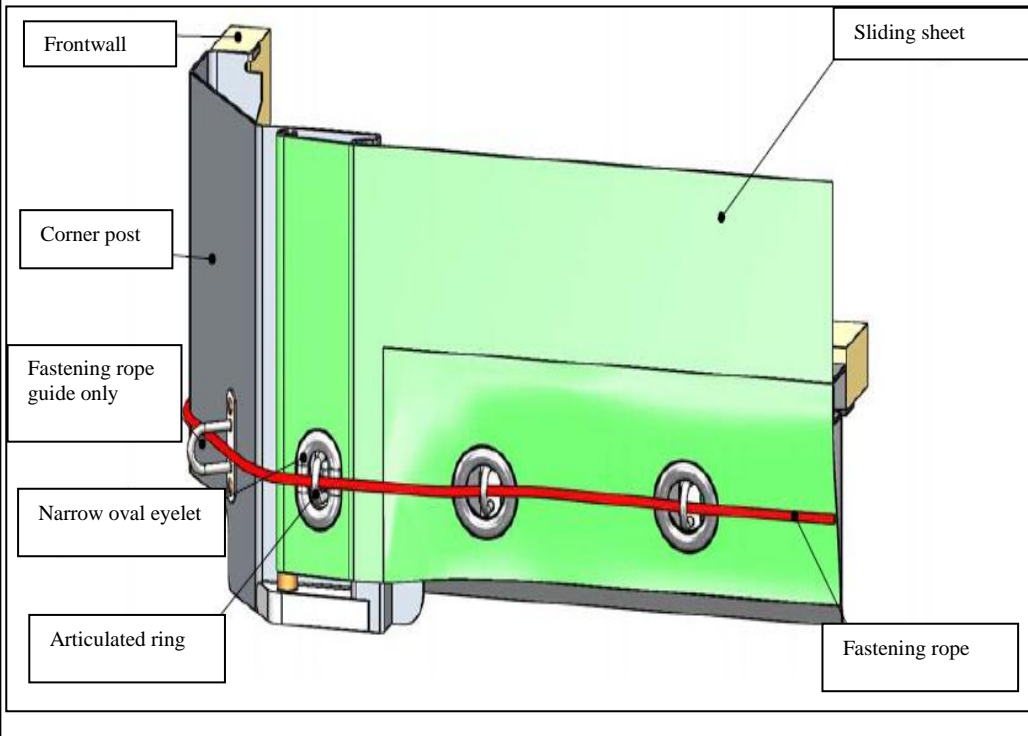

Annex 2, new Sketch No. 10

After new Sketch No. 9 insert

Sketch No. 10

EXAMPLE OF A CONSTRUCTION OF A VEHICLE WITH A SHEETED SLIDING ROOF

This sketch shows an example of a vehicle and the important requirements described in Article 5 of these Regulations.

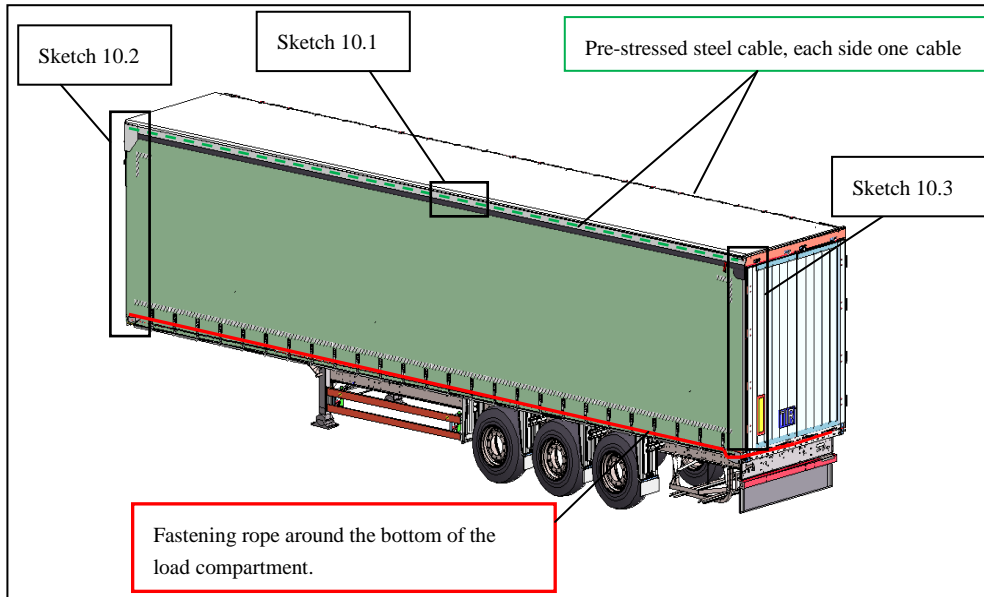

Sketch No. 10.1

Two pre-stressed steel cables, embedded in a hem, are fixed on each side of the load compartment. This pre-stressed steel cable is fixed to the front (see sketch 10.2) and rear of the body (see sketch 10.3). The tractive force as well as the connecting disc on each sliding carriage makes it impossible to lift up the hem with the pre-stressed steel cable above the upper cantrail.

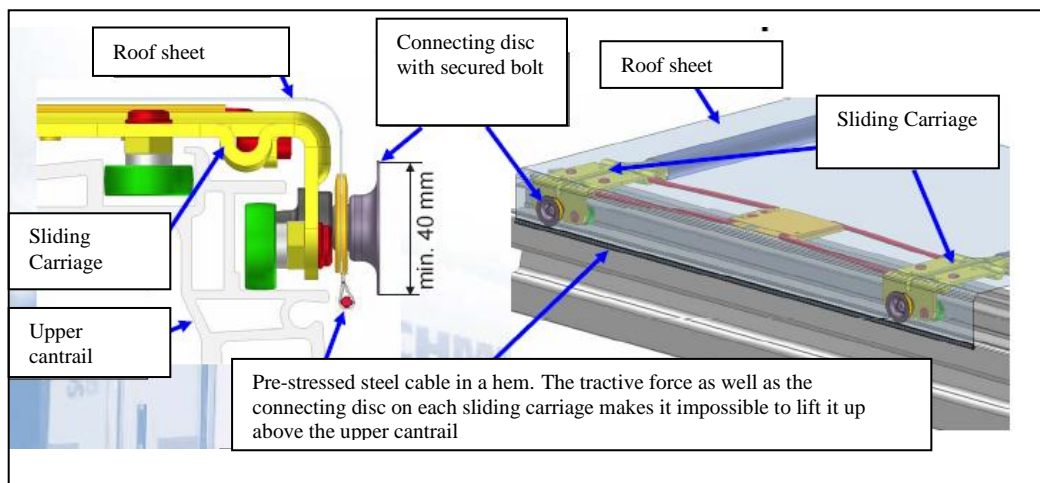

Sketch No. 10 continued

Sketch No.10.2

The sliding roof sheet shall overlap with the solid part of the roof at the front side of the load compartment, so that the roof sheet cannot be pulled over the top edge of the upper cantrail.

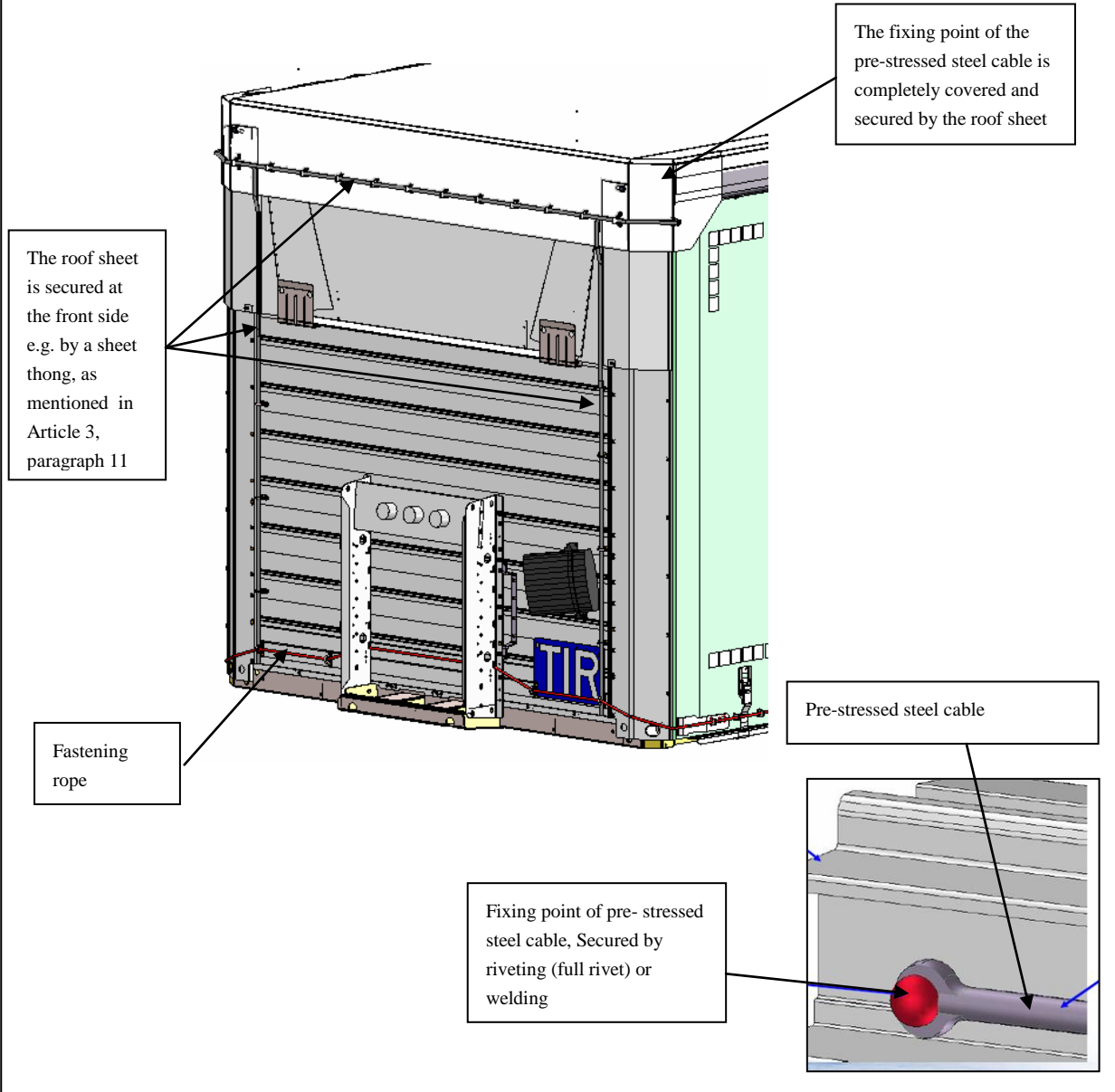

Sketch No. 10 continued

Sketch No.10.3

At the rear, a special device, such as a baffle plate, is fitted to the roof, preventing access to the load compartment, without leaving obvious traces when the doors are closed and sealed.

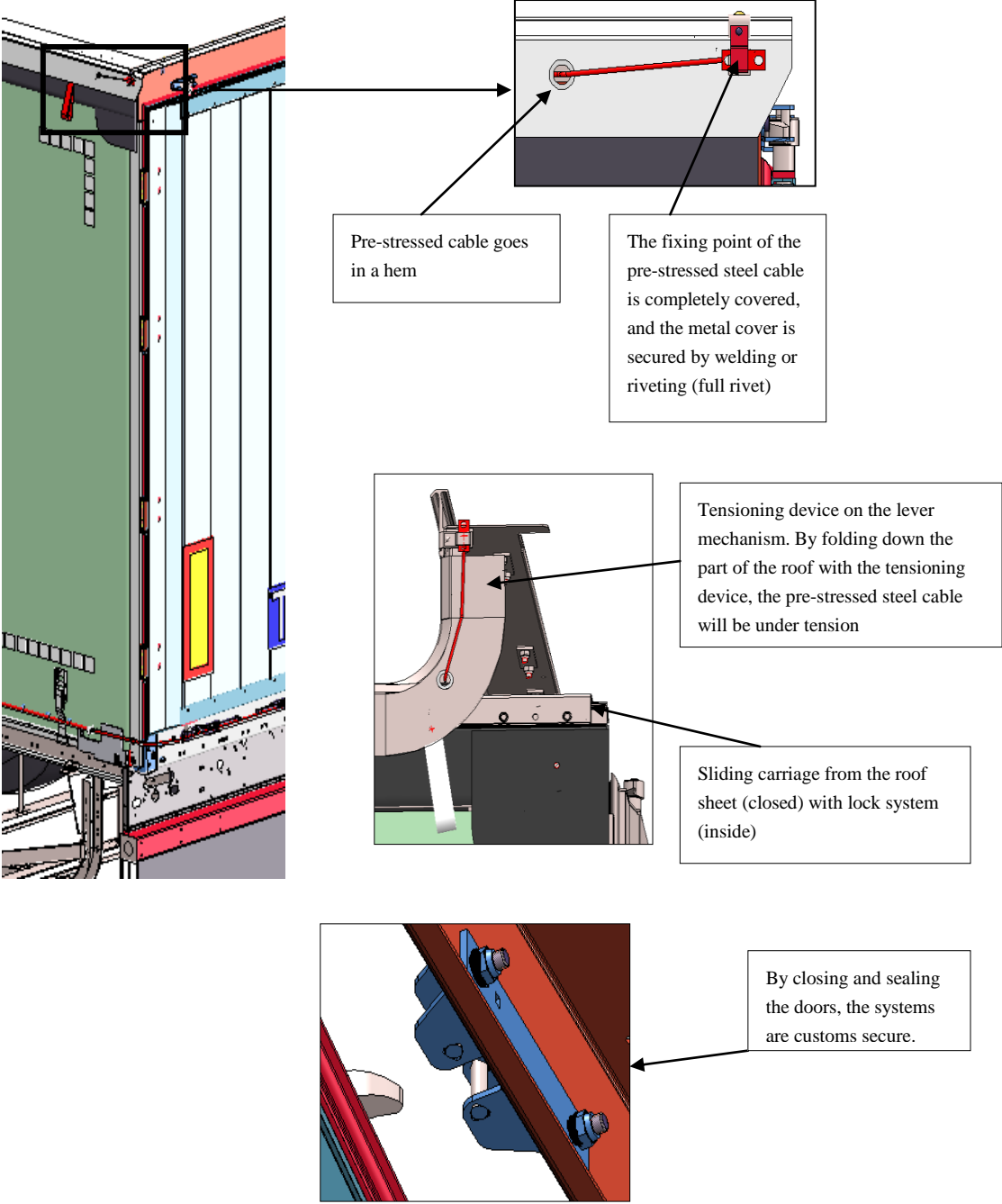

Annex 7, Part I, Article 5, paragraph 2, (i)

For the existing text substitute

(i) The sliding sheets, floor, doors and all other constituent parts of the container shall be assembled either by means of devices which cannot be removed and replaced from the outside without leaving obvious traces, or by such methods as will produce a structure which cannot be modified without leaving obvious traces.

Annex 7, Part I, Article 5, paragraph 2, (iii)

For the existing text substitute

(iii) The sliding sheet guidance, sliding sheet tension devices and other movable parts shall be assembled in such a way that when closed, and Customs sealed, doors and other movable parts cannot be opened or closed from the outside without leaving obvious traces. The sliding sheet guidance, sliding sheet tension devices and other movable parts shall be assembled in such a way that it is impossible to gain access to the container without leaving obvious traces once the closing devices has been secured. An example of such a system of construction is given in sketch No. 9 appended to these Regulations.”

Annex 7, Part I, new Article 6

After the modified Article 5 insert

Article 6

Containers with a sheeted sliding roof

1. Where applicable, the provisions of Articles 1, 2, 3, 4 and 5 of these Regulations shall apply to containers with a sheeted sliding roof. In addition, these containers shall conform to the provisions of this Article.
2. The sheeted sliding roof shall fulfil the requirements set out in (i) to (iii) below.
 - (i) The sheeted sliding roof shall be assembled either by means of devices which cannot be removed and replaced from the outside without leaving obvious traces, or by such methods as will produce a structure which cannot be modified without leaving obvious traces.
 - (ii) The sliding roof sheet shall overlap with the solid part of the roof at the front side of the container, so that the roof sheet cannot be pulled over the top edge of the upper cantrail. In the length of the container, at both sides, in the hem of the roof sheet, a pre-stressed steel cable shall be inserted in such a way that it cannot be removed and re-inserted without leaving obvious traces. The roof sheet shall be secured to the sliding carriage in such a way that it cannot be removed and re-secured without leaving obvious traces.
 - (iii) The sliding roof guidance, the sliding roof tension devices and other movable parts shall be assembled in such a way that when closed, and Customs sealed, doors, roof and other movable parts cannot be opened or closed from the outside without leaving obvious traces. The sliding roof guidance, sliding roof tension devices and other movable parts shall be assembled in such a way that it is impossible to gain access to the container without leaving obvious traces once the closing devices have been secured.

An example of a possible system of construction is shown in sketch No. 10, appended to these Regulations.

Annex 7, Part I, Sketch No. 9

For the existing Sketch No. 9 substitute

Sketch No. 9

EXAMPLE OF A CONSTRUCTION OF A CONTAINER WITH SLIDING SHEETS

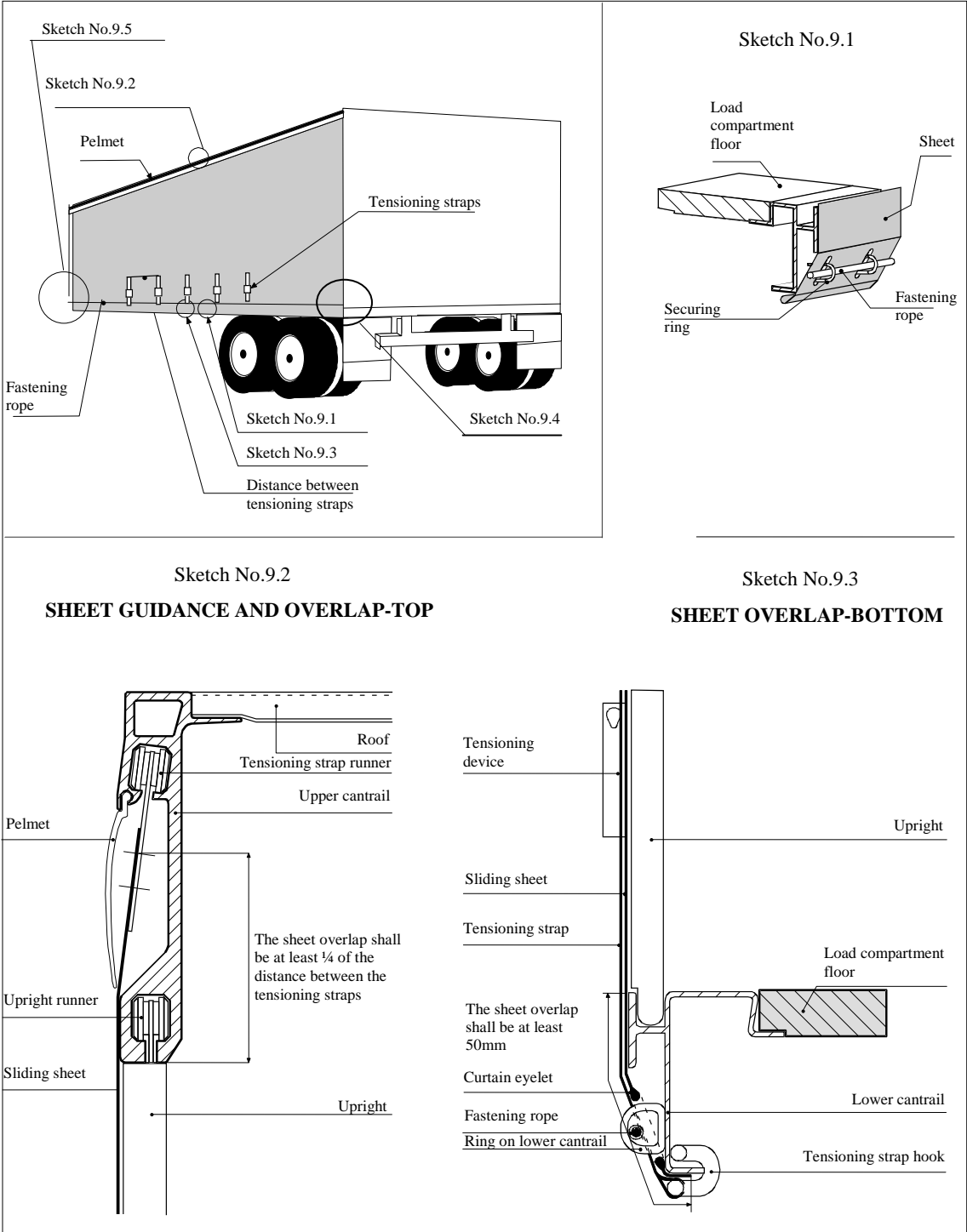

Sketch No. 9 continued

Sketch No. 9.4

To tighten the sliding sheets in the horizontal direction, a ratchet gear is used (normally at the rear end of the container). This sketch shows two examples, (a) and (b), of how the ratchet or gearbox may be secured.

(a) Ratchet securing

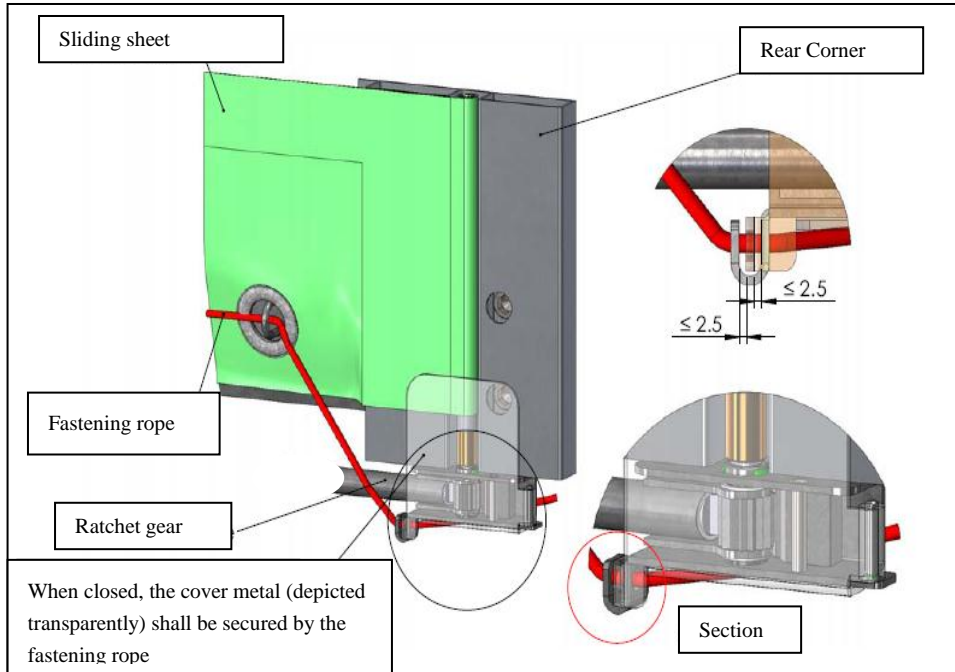

(b) Gearbox securing

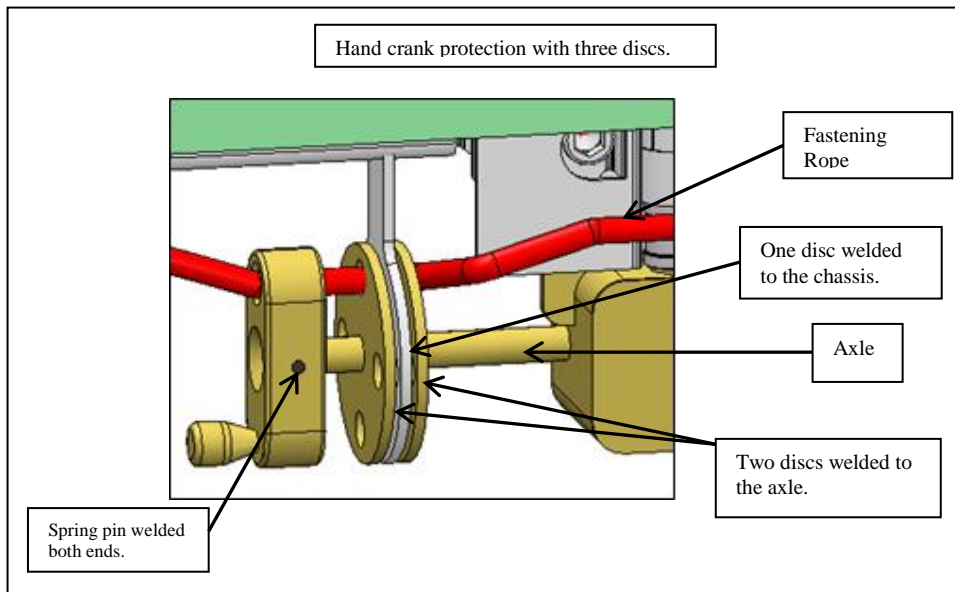

Sketch No. 9 continued

Sketch No. 9.5

To fix the sliding sheet on the other side (normally the front of the container), the following systems, (a) or (b), may be used.

(a) Cover metal

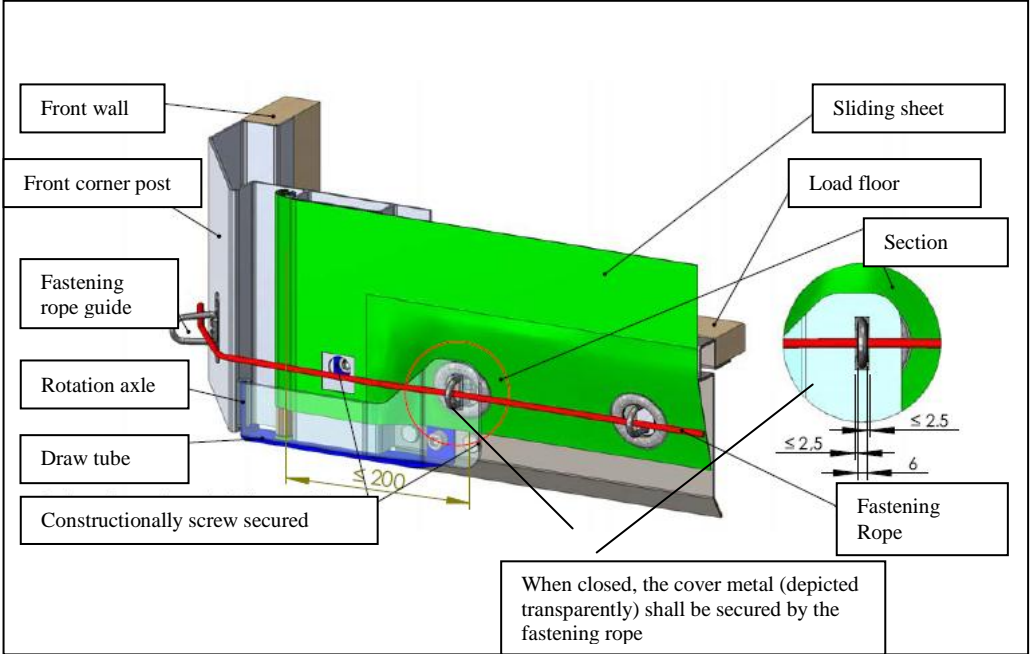

(b) Narrow oval eyelet, anti-lifting system for the tensioning tube

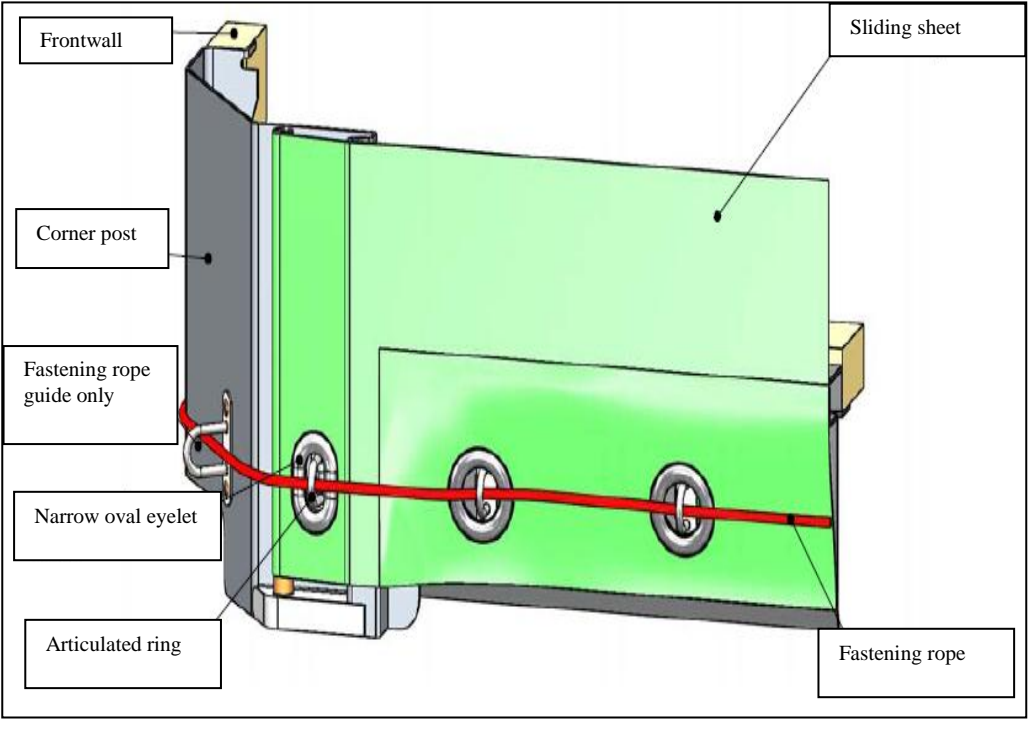

Annex 7, Part I, Sketch No. 9

After new Sketch No. 9 insert

Sketch No. 10

EXAMPLE OF A CONSTRUCTION OF A CONTAINER WITH A SHEETED SLIDING ROOF

This sketch shows an example of a container and the important requirements described in Article 6 of these Regulations.

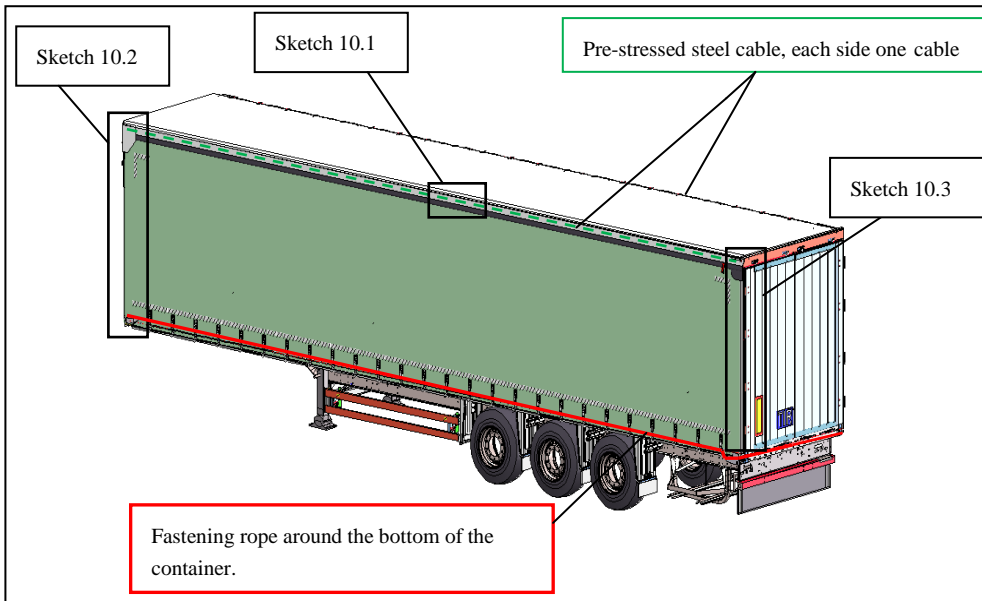

Sketch No. 10.1

Two pre-stressed steel cables, embedded in a hem, are fixed on each side of the container. This pre-stressed steel cable is fixed to the front (see sketch 10.2) and rear of the body (see sketch 10.3). The tractive force as well as the connecting disc on each sliding carriage makes it impossible to lift up the hem with the pre-stressed steel cable above the upper cantrail.

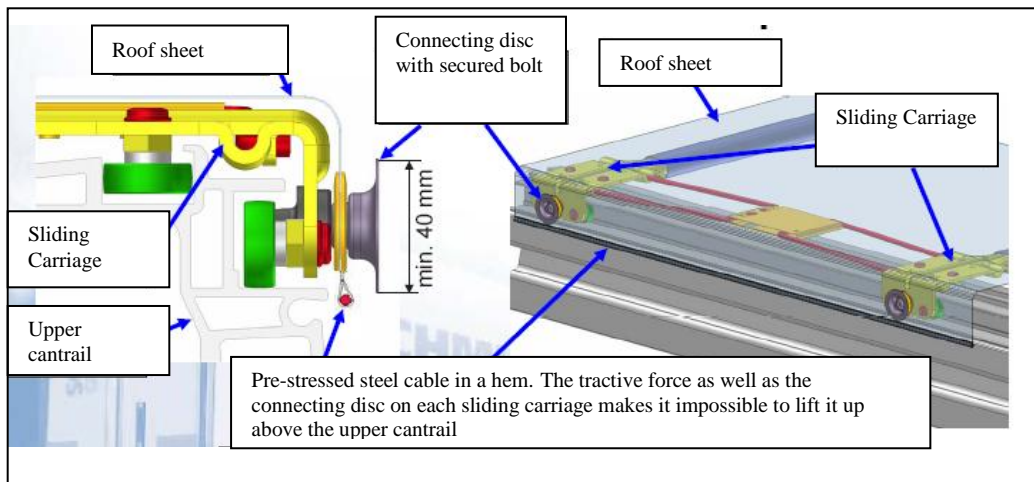

Sketch No. 10 continued

Sketch No.10.2

The sliding roof sheet shall overlap with the solid part of the roof at the front side of the container, so that the roof sheet cannot be pulled over the top edge of the upper cantrail

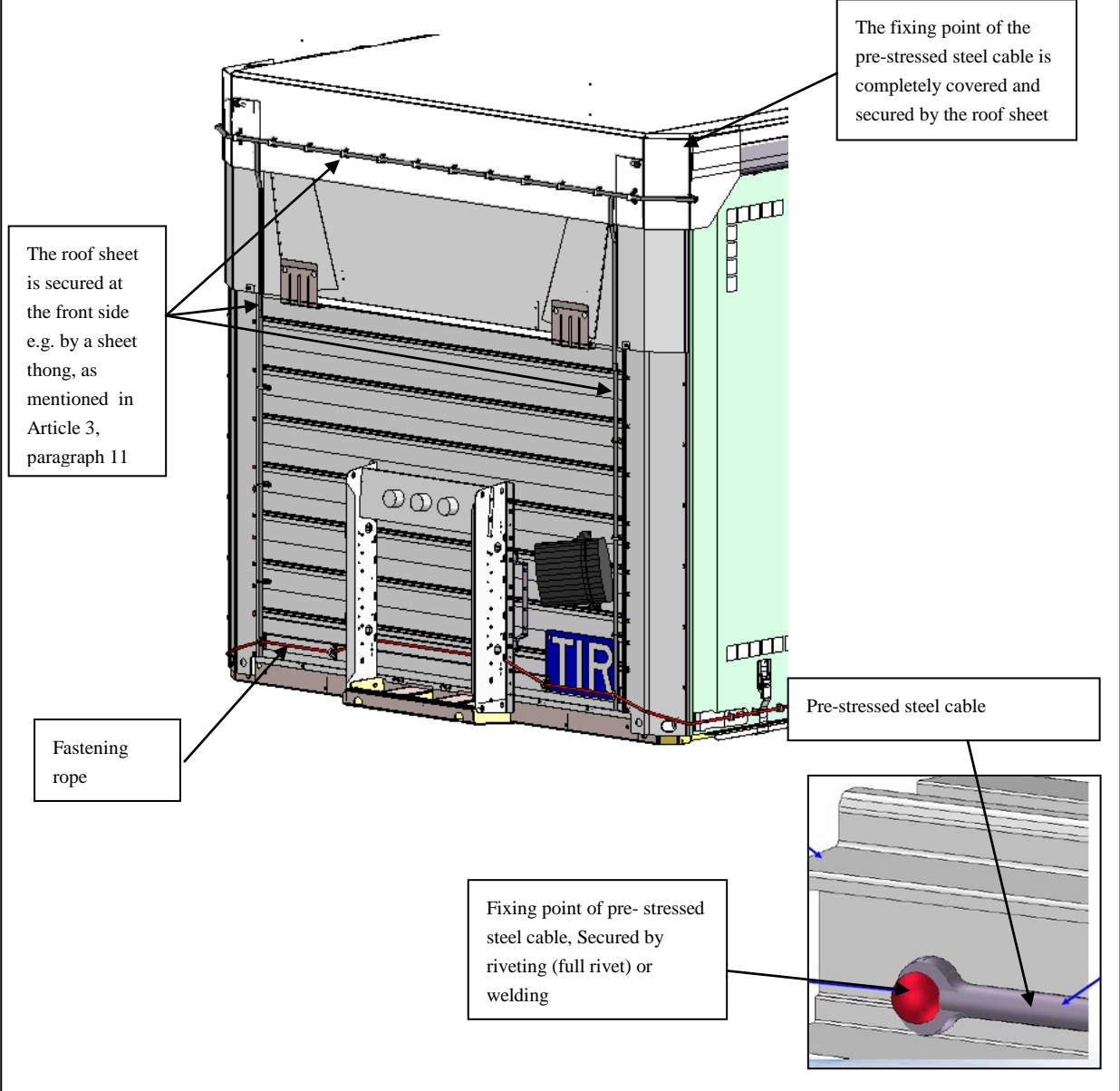

Sketch No. 10 continued

Sketch No.10.3

At the rear, a special device, such as a baffle plate, is fitted to the roof, preventing access to the container, without leaving obvious traces when the doors are closed and sealed.

