



UN/CEFACT

Simple, Transparent and Effective Processes
For Global Commerce

REQUIREMENTS SPECIFICATION MAPPING (RSM)

Business Domain: Cross Industry – Supply Chain

Business Process: Market Survey Information Supply

Title: Cross Industry Market Survey Information Supply Process

UN/CEFACT International Trade and Business Processes Group: TBG1

Version: 1.00.01

Release: 1

Date of TBG approval: 20 November 2009

Document Summary

Document Item	Current Value
Document Title	Requirements Specification Mapping Cross Industry Market Survey Information Supply Process
Date Last Modified	May 7, 2010
Current Document Version	1.00.01
Status	Final
Document Description (one sentence summary)	Specification that describes the data model and targeted technology solutions for the market survey information supply process.

Contributors

Name	Organization

Log of Changes

Issue No.	Date of Change	Changed By	Summary of Change
1.00.00	10-Nov-2009	TBG1	Provided the RSM in the format as required by ICG.
1.00.01	20-Nov-2009		TBG Steering approval

TABLE OF CONTENTS

1.	Preamble	4
2.	References	4
3.	Objective	4
4.	Definition of terms.....	5
5.	Target technology solutions	5
6.	Information payload to be implemented	6
6.1.	Conceptual Data Model for the Cross Industry Market Survey Information Supply	6
6.2.	Canonical Data Model for the Cross Industry Market Survey Information Supply	7
6.2.1.	eMarket Research.....	8
6.2.1.1.	Market Survey Information	8
6.2.1.2.	Market Survey Information Request.....	9
6.2.2.	Cross Industry Common.....	10
6.2.2.1.	CI Referenced Document, CI Trade Party	10
7.	Business information entity reference.....	11
7.1.	Basic Business Information Entities section.....	11
7.2.	Aggregate Business Information Entities section	12
8.	Core components UN/CEFACT Registry version used	39
9.	Draft Core Component reference.....	39
10.	Additional documentation	39
11.	Additional information	39

1. Preamble

The current practice of the exchange of business documents by means of telecommunications – usually defined as e-Business presents a major opportunity to improve the competitiveness of companies, especially for Small and Medium Enterprises (SME).

The market research (MR) departments in most multinational companies and specialized market research companies sit on a plethora of information, collected through a variety of Market Surveys, that combined will give invaluable information on the different societies, their citizens' behaviour as consumers and political and social actors.

This information can be used by governments and companies alike to improve the societies and also to develop new products and improve products already on the market. Some of this information may be shared openly whereas some may be proprietary and protected.

While trade associations like ESOMAR have established ISO standards (ISO 20252) related to ethics and code of conduct within the MR industry, the industry **has no standardized approach for identifying, classifying, marketing and exchanging this information in a rational way.**

The need for standardization in this area is further strengthened by the fact that information in general has become a commercial commodity. That goes especially for background information on consumer and voter behaviour addressing question such as:

- Why are people buying this and not that?
- Why do they prefer political party A over political party B?
- What is the market behaviour in countries X, Z and Y?
- Why do they differ and on what subjects?

As information in general has become a commercial commodity it may be traded essentially like any other product by applying general trading processes. Market Research is about opinions and attitudes (and not characteristics of a product or service) for which there is a need to define standardised exchange formats for describing the type of information available as well as for providing the actual information.

To address this situation an activity is established within UN/CEFACT TBG1 to “obtain Business Process Models and the business transaction class diagrams for documenting business scenarios and the business transactions involved in the market research, indexing and information exchange processes. These class diagrams will be used to obtain the XML messages to support these business processes.”

The structure of this document is based on the structure of the UN/CEFACT Requirements Specification Mapping (RSM) – Documentation Template and Conformity Rules, document reference CEFACT/ICG/006.

2. References

- UN/CEFACT TBG1 Cross Industry Market Service Information BRS, Release 1

3. Objective

In conjunction with the BRS document (CEFACT/ICG/005), the purpose of this document is to provide a standard framework for the exchange of information for Market Survey Information Supply.

4. Definition of terms

Please refer to the BRS for more background on the used terminology.

5. Target technology solutions

The MSI and MSI Request solutions require a UN/CEFACT XML standard schema.

The MSI and MSI Request solutions will not be implemented as a UN/EDIFACT standard message.

6. Information payload to be implemented

6.1. Conceptual Data Model for the Cross Industry Market Survey Information Supply

Figure 6-1 Conceptual model

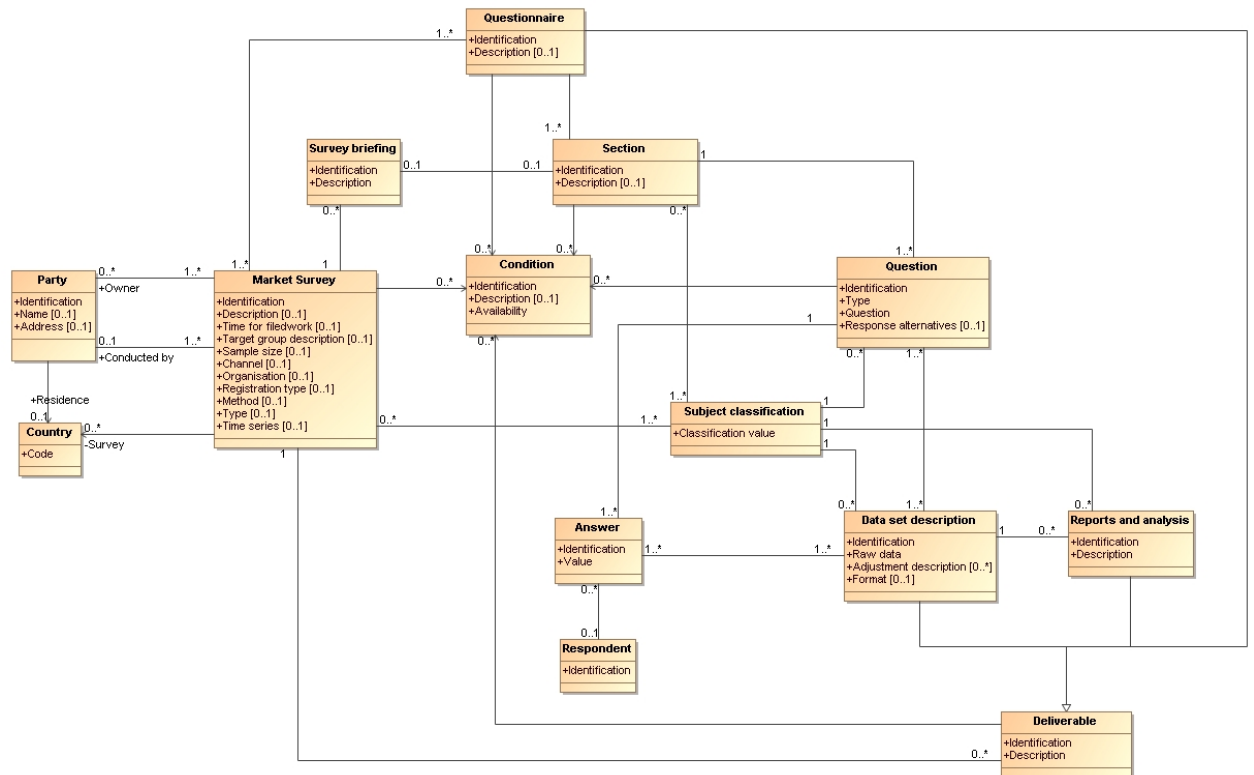

Description of the main entities

The key relationships illustrated in this model are:

A *Market Survey* may be owned by more than one *Party* and may be conducted by a one, and only one, *Party* (typically a Market Research institute). A *Market Survey* may be conducted through one or more *Questionnaires*, and may be supported by more than one *Survey Briefings* (typically the case if the supporting *Questionnaire* contains several sections). A *Market Survey* covers subjects described through one or more *Subject Classifications*, and may be relevant for more than one *Country*. A *Market Survey* may have many *Deliverables* and its content may be available subject to more than one *Condition*.

A *Questionnaire* consists of one or more *Sections*, each containing one or more *Questions*. The individual *Section(s)* cover subjects described through one or more *Subject Classifications* (the subject of the *Questionnaire* itself is thus identified through the subject of its different sections). A *Section* (of a *Questionnaire*) will contain one or more individual *Question(s)*, each covering one, and only one, *Subject Classification*. The *Questionnaire* as well as its *Section(s)* and individual *Question(s)* may be available subject to more than one *Condition*.

The *Deliverable(s)* typically made available as a result of a *Market Survey* are *Reports and analysis*, the *Questionnaire*, an individual *Question* or *Data Sets* – in the model represented as *Data set description*. *Deliverables* may be available subject to more than one *Condition*.

A *Data Sets* – in the model represented as *Data set description* – is built up by one or more *Answers* provided in response to one or more *Questions*. An *Answer* is given in response to one, and only one, *Question*, and may have one identified *Respondent*. The subject covered by a data set is described through one or more *Subject Classifications*.

A *Reports and analysis* is based on one, and only one, data set covering subjects described through one, and only one, *Subject Classifications*.

6.2. Canonical Data Model for the Cross Industry Market Survey Information Supply

For readability reasons the canonical model is provided in multiple diagrams, each providing a full description of a segment in the Cross Industry Invoice.

6.2.1. eMarket Research

6.2.1.1. Market Survey Information

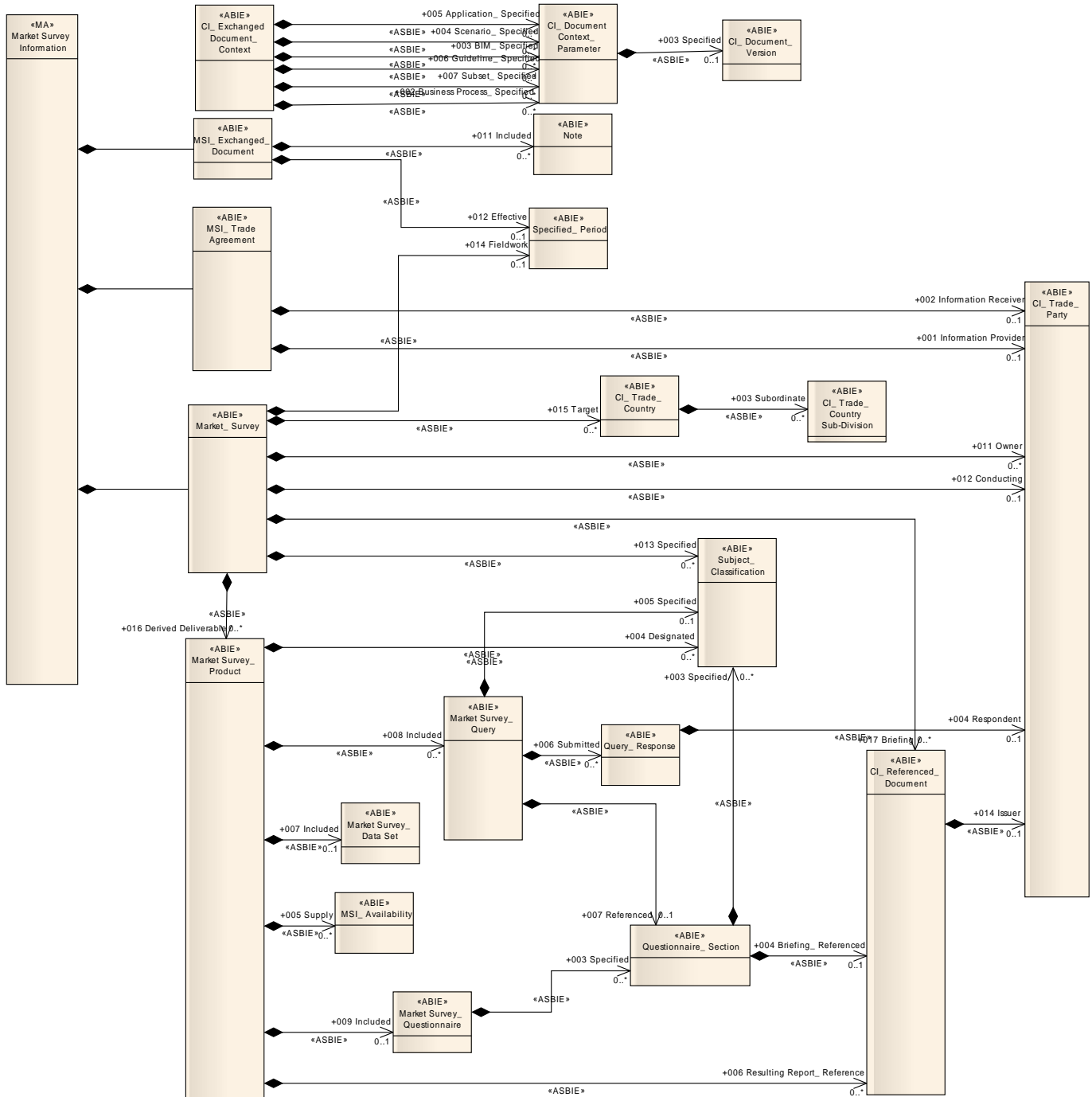

6.2.2. Cross Industry Common

6.2.2.1. CI Referenced Document, CI Trade Party

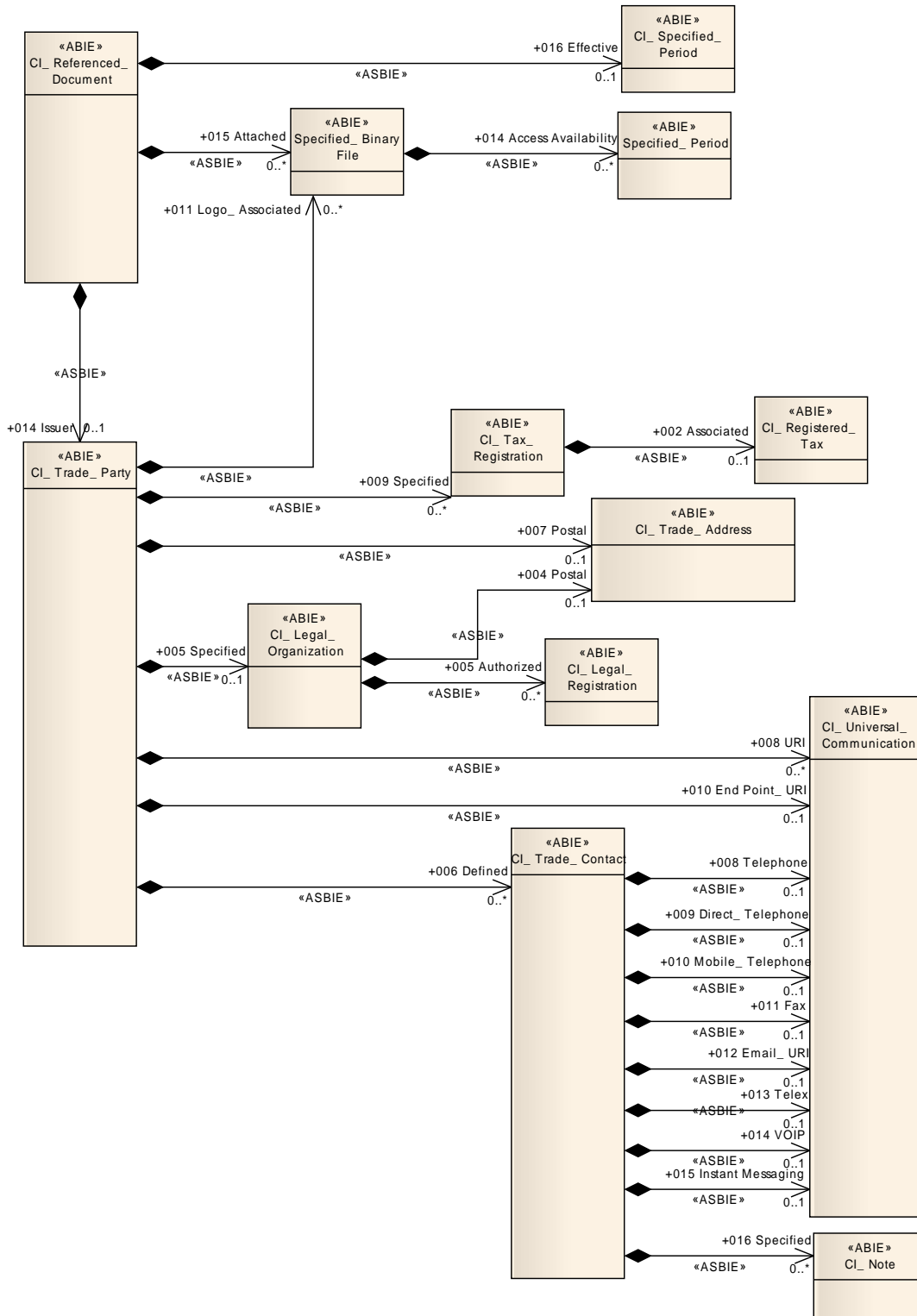

7. Business information entity reference

This section contains the list of all the Business Information Entities that are both used within the canonical data model and are variations from the standard Core Components, including the UN/CEFACT Registry version that served as the reference point.

7.1. Basic Business Information Entities section

This section identifies any restrictions that have to be applied to the BBIE in the context in which it is being used.

BBIE Dictionary Entry Name	Qualified Data Type	Core Component DEN	CC Restriction Type (CII specific only)	CC Restriction (CII specific only)	SC Restriction Type (CII specific only)	SC Restrictions (CII specific only)	UNCL TDED
MSI_ Exchanged_ Document. Type. Code	Document	Document. Type. Code	Enumeration	UNCL 1001 list	None	None	1001
MSI_ Exchanged_ Document. Status. Code	Status	Document. Status. Code	Enumeration	UNCL 4405 list	None	None	4405
CI_ Trade_ Party. Role. Code	Party Role	Party. Role. Code	Enumeration	UNCL 3035 list	None	None	3035
CI_ Referenced_ Document. Issue. Date Time	Date Mandatory	Document. Issue. Date Time	None	None	None	None	2007
CI_ Referenced_ Document. Reference_ Type. Code	Reference	Document. Reference_ Type. Code	Enumeration	UNCL 1153 list	None	None	1153

7.2. Aggregate Business Information Entities section

Occurrence	Element/Attribute
	CI_ Exchanged Document_ Context. Details
0 .. 1	<i>CI_ Exchanged Document_ Context. Specified_ Transaction. Identifier</i> Business Requirement 07/11/2008 CSC DOC0014 0..1 Transaction Type ID (i.e. Guideline Transaction type ID)
0 .. unbounded	CI_ Exchanged Document_ Context. Business Process_ Specified. CI_ Document Context_ Parameter Main::CI_ Document Context_ Parameter. Details
0 .. 1	<i>CI_ Document Context_ Parameter. Identification. Identifier</i> Business Requirement 07/11/2008 CSC DOC0012 0..1 Version ID (standard i.e. BRS and/or BIM)
0 .. 1	<i>CI_ Document Context_ Parameter. Value. Text</i>
0 .. unbounded	CI_ Exchanged Document_ Context. BIM_ Specified. CI_ Document Context_ Parameter Main::CI_ Document Context_ Parameter. Details
0 .. 1	<i>CI_ Document Context_ Parameter. Identification. Identifier</i> Business Requirement 07/11/2008 CSC DOC0012 0..1 Version ID (standard i.e. BRS and/or BIM)
0 .. 1	<i>CI_ Document Context_ Parameter. Value. Text</i>
0 .. unbounded	CI_ Exchanged Document_ Context. Scenario_ Specified. CI_ Document Context_ Parameter Main::CI_ Document Context_ Parameter. Details
0 .. unbounded	CI_ Exchanged Document_ Context. Application_ Specified. CI_ Document Context_ Parameter Main::CI_ Document Context_ Parameter. Details
0 .. unbounded	CI_ Exchanged Document_ Context. Guideline_ Specified. CI_ Document Context_ Parameter Main::CI_ Document Context_ Parameter. Details
0 .. 1	<i>CI_ Document Context_ Parameter. Identification. Identifier</i> Business Requirement 07/11/2008 CSC DOC0013 0..1 Version ID (standard i.e. Subset guideline)
0 .. 1	<i>CI_ Document Context_ Parameter. Value. Text</i>
0 .. unbounded	CI_ Exchanged Document_ Context. Subset_ Specified. CI_ Document Context_ Parameter Main::CI_ Document Context_ Parameter. Details

Occurrence	Element/Attribute
MSI_ Exchanged_ Document. Details	
1 .. 1	MSI_ Exchanged_ Document. Identification. Identifier Business Requirement 12/07/2008 CSC DOC0001 1..1 Document ID
0 .. unbounded	MSI_ Exchanged_ Document. Name. Text Business Requirement 12/07/2008 CSC DOC0003 0..1 Document Name
0 .. 1	MSI_ Exchanged_ Document. Type. Code Business Requirement 08/09/2008 CSC DOC0018 0..1 Document Type Code
0 .. 1	MSI_ Exchanged_ Document. Status. Code Business Requirement 12/07/2008 CSC DOC0009 0..1 Document Status Code
0 .. 1	MSI_ Exchanged_ Document. Issue. Date Time Business Requirement 12/07/2008 CSC DOC0002 1..1 Issue Date Time - Option needed to have
0 .. 1	MSI_ Exchanged_ Document. Copy. Indicator Business Requirement 12/07/2008 CSC DOC0008 0..1 Copy Indicator
0 .. unbounded	MSI_ Exchanged_ Document. Purpose. Code Business Requirement 08/09/2008 CSC DOC0019 0..1 Document purpose code
0 .. 1	MSI_ Exchanged_ Document. Version_ Identification. Identifier Business Requirement 12/07/2008 CSC DOC0012 0..1 Version ID
0 .. 1	MSI_ Exchanged_ Document. Revision_ Identification. Identifier Business Requirement 12/07/2008 CSC DOC0006 0..1 Index ID - mapped to Revision which refers
0 .. 1	MSI_ Exchanged_ Document. Previous Revision_ Identification. Identifier Business Requirement 12/07/2008 CSC DOC0007 0..1 Previous Index ID - mapped to Revision
0 .. unbounded	MSI_ Exchanged_ Document. Included. Note Main::Note. Details Business Requirement 12/07/2008 CSC DOC0016 0.* Note
0 .. 1	MSI_ Exchanged_ Document. Effective. Specified_ Period Main::Specified_ Period. Details Business Requirement 12/07/2008 CSC DOC0015 0..1 Validity Period

Occurrence	Element/Attribute
MSI_Trade Agreement. Details	
0 .. 1	MSI_Trade Agreement. Information Provider. CI_Trade_Party Main::CI_Trade_Party. Details
0 .. 1	MSI_Trade Agreement. Information Receiver. CI_Trade_Party Main::CI_Trade_Party. Details

Occurrence	Element/Attribute
	Market_Survey. Details
0 .. unbounded	—Market_Survey. Identification. Identifier Business Requirement 07/07/2009 MSS MSS0001 1..1 Market Survey ID
0 .. unbounded	—Market_Survey. Description. Text Business Requirement 07/07/2009 MSS MSS0002 0..1 Market Survey Description
0 .. unbounded	—Market_Survey. Target Group_ Description. Text Business Requirement 07/07/2009 MSS MSS0004 0..1 Target Group Description
0 .. 1	—Market_Survey. Sample Size. Quantity Business Requirement 07/07/2009 MSS MSS0005 0..1 Sample Size
0 .. unbounded	—Market_Survey. Communication Channel. Code Business Requirement 07/07/2009 MSS MSS0006 0..1 Channel
0 .. 1	—Market_Survey. Organization_ Process. Code Business Requirement 07/07/2009 MSS MSS0007 0..1 Organisation
0 .. 1	—Market_Survey. Recording_ Process. Code Business Requirement 07/07/2009 MSS MSS0008 0..1 Registration type
0 .. unbounded	—Market_Survey. Method. Code Business Requirement 07/07/2009 MSS MSS0009 0..1 Method
0 .. unbounded	—Market_Survey. Type. Code Business Requirement 07/07/2009 MSS MSS0010 0..1 Type
0 .. 1	—Market_Survey. Time Series. Indicator Business Requirement 07/07/2009 MSS MSS0011 0..1 Time series
0 .. unbounded	—Market_Survey. Owner. CI_ Trade_ Party Main::CI_ Trade_ Party. Details Business Requirement 07/07/2009 MSS MSS0012 0..1 Owner Party
0 .. 1	—Market_Survey. Conducting. CI_ Trade_ Party Main::CI_ Trade_ Party. Details Business Requirement 07/07/2009 MSS MSS0016 0..1 Conducted By Party
0 .. unbounded	—Market_Survey. Specified. Subject_ Classification Main::Subject_ Classification. Details Business Requirement 07/07/2009 MSS MSS0043 0..* Subject Classification
0 .. 1	—Market_Survey. Fieldwork. Specified_ Period Main::Specified_ Period. Details Business Requirement 07/07/2009 MSS MSS0003 0..1 Time for fieldwork
0 .. unbounded	—Market_Survey. Target. CI_ Trade_ Country Main::CI_ Trade_ Country. Details Business Requirement 07/07/2009 MSS MSS0022 0..1 Target Country
0 .. unbounded	—Market_Survey. Derived Deliverable. Market Survey_ Product Main::Market Survey_ Product. Details Business Requirement 07/07/2009 MSS MSS0045 0..* Deliverable
0 .. unbounded	—Market Survey_ Product. Identification. Identifier Business Requirement 07/07/2009 MSS MSS0046 1..1 Deliverable ID
0 .. unbounded	—Market Survey_ Product. Description. Text

Occurrence	Element/Attribute
0 .. 1	<ul style="list-style-type: none"> Business Requirement <ul style="list-style-type: none"> 07/07/2009 MSS MSS0047 0..1 Deliverable description
0 .. 1	Market Survey_ Product. Type. Code
0 .. unbounded	<ul style="list-style-type: none"> Market Survey_ Product. Designated. Subject_ Classification <ul style="list-style-type: none"> Main::Subject_ Classification. Details
0 .. unbounded	<ul style="list-style-type: none"> Business Requirement <ul style="list-style-type: none"> 07/07/2009 MSS MSS0043 0.* Subject Classification
0 .. unbounded	<ul style="list-style-type: none"> Market Survey_ Product. Supply. MSI_ Availability <ul style="list-style-type: none"> Main::MSI_ Availability. Details
0 .. 1	<ul style="list-style-type: none"> Business Requirement <ul style="list-style-type: none"> 07/07/2009 MSS MSS0056 0.* Availability Conditions
0 .. 1	MSI_ Availability. Identification. Identifier
0 .. 1	<ul style="list-style-type: none"> Business Requirement <ul style="list-style-type: none"> 07/07/2009 MSS MSS0057 1..1 Availability Conditions ID
0 .. 1	MSI_ Availability. Description. Text
0 .. 1	<ul style="list-style-type: none"> Business Requirement <ul style="list-style-type: none"> 07/07/2009 MSS MSS0058 0..1 Availability Conditions Description
0 .. 1	MSI_ Availability. Status. Code
0 .. unbounded	<ul style="list-style-type: none"> Business Requirement <ul style="list-style-type: none"> 07/07/2009 MSS MSS0056 1..1 Availability Conditions Status Code
0 .. unbounded	<ul style="list-style-type: none"> Market Survey_ Product. Resulting Report_ Reference. CI_ Referenced_ Document <ul style="list-style-type: none"> Main::CI_ Referenced_ Document. Details
0 .. 1	<ul style="list-style-type: none"> Business Requirement <ul style="list-style-type: none"> 07/07/2009 MSS MSS0053 0.* Reports and analysis
0 .. 1	CI_ Referenced_ Document. Issuer Assigned_ Identification. Identifier
0 .. 1	<ul style="list-style-type: none"> Business Requirement <ul style="list-style-type: none"> 07/07/2009 MSS MSS0054 1..1 Report/Analysis ID
0 .. 1	CI_ Referenced_ Document. URL_ Identification. Identifier
0 .. 1	<ul style="list-style-type: none"> Business Requirement <ul style="list-style-type: none"> 12/07/2008 CSC REF0006 0..1 Reference URI
0 .. 1	CI_ Referenced_ Document. Issue. Date Time
0 .. 1	<ul style="list-style-type: none"> Business Requirement <ul style="list-style-type: none"> 12/07/2008 CSC REF0003 0..1 Reference date
0 .. 1	CI_ Referenced_ Document. Status. Code
0 .. 1	<ul style="list-style-type: none"> Business Requirement <ul style="list-style-type: none"> 12/07/2008 CSC REF0004 0..1 Reference status
0 .. 1	CI_ Referenced_ Document. Copy. Indicator
0 .. 1	<ul style="list-style-type: none"> Business Requirement <ul style="list-style-type: none"> 12/07/2008 CSC REF0008 0..1 Copy indicator
0 .. 1	CI_ Referenced_ Document. Line. Identifier
0 .. 1	<ul style="list-style-type: none"> Business Requirement <ul style="list-style-type: none"> 12/07/2008 CSC REF0009 0..1 Reference line number
0 .. 1	CI_ Referenced_ Document. Reference_ Type. Code
0 .. 1	<ul style="list-style-type: none"> Business Requirement <ul style="list-style-type: none"> 08/09/2008 CSC REF0012 0..1 Document type
0 .. 1	CI_ Referenced_ Document. Global_ Identification. Identifier
0 .. 1	<ul style="list-style-type: none"> Business Requirement <ul style="list-style-type: none"> 08/09/2008 CSC REF0007 0..1 Reference GUID
0 .. 1	CI_ Referenced_ Document. Revision_ Identification. Identifier
0 .. unbounded	<ul style="list-style-type: none"> Business Requirement <ul style="list-style-type: none"> 08/09/2008 CSC REF0005 0..1 Reference index ID
0 .. unbounded	CI_ Referenced_ Document. Name. Text
0 .. unbounded	<ul style="list-style-type: none"> Business Requirement <ul style="list-style-type: none"> 12/07/2008 CSC REF0002 0..1 Reference Document Name
0 .. unbounded	CI_ Referenced_ Document. Information. Text
0 .. unbounded	<ul style="list-style-type: none"> Business Requirement <ul style="list-style-type: none"> 07/07/2009 MSS MSS0055 1..1 Report/Analysis description
0 .. unbounded	CI_ Referenced_ Document. Previous Revision_ Identification. Identifier
0 .. unbounded	CI_ Referenced_ Document. Section Name. Text

Occurrence	Element/Attribute
0 .. 1	Market Survey_ Product. Included. Market Survey_ Data Set Main::Market Survey_ Data Set. Details
	Business Requirement
0 .. unbounded	07/07/2009 MSS MSS0048 0..1 Data Set
	Market Survey_ Data Set. Identification. Identifier
	Business Requirement
0 .. 1	07/07/2009 MSS MSS0049 1..1 Data Set ID
	Market Survey_ Data Set. Raw Data. Indicator
	Business Requirement
0 .. unbounded	07/07/2009 MSS MSS0050 0..1 Data Set Raw Data Indicator
	Market Survey_ Data Set. Format_ Description. Text
	Business Requirement
0 .. unbounded	07/07/2009 MSS MSS0052 0..1 Data Set Format
	Market Survey_ Data Set. Adjustment_ Description. Text
	Business Requirement
0 .. unbounded	07/07/2009 MSS MSS0051 0..1 Data Set Adjustment description
0 .. unbounded	Market Survey_ Product. Included. Market Survey_ Query Main::Market Survey_ Query. Details
	Business Requirement
0 .. 1	07/07/2009 MSS MSS0033 0.* Question
	Market Survey_ Product. Included. Market Survey_ Questionnaire Main::Market Survey_ Questionnaire. Details
	Business Requirement
0 .. unbounded	07/07/2009 MSS MSS0027 0..1 Questionnaire
	Market Survey_ Questionnaire. Identification. Identifier
	Business Requirement
0 .. unbounded	07/07/2009 MSS MSS0028 1..1 Questionnaire ID
	Market Survey_ Questionnaire. Description. Text
	Business Requirement
0 .. unbounded	07/07/2009 MSS MSS0029 1..1 Questionnaire Description
0 .. unbounded	Market_ Survey. Briefing. CI_ Referenced_ Document Main::CI_ Referenced_ Document. Details
	Business Requirement
07/07/2009	MSS MSS0024 0..1 Survey Briefing

Occurrence	Element/Attribute
	Requested_Market_Survey_Details
0 .. unbounded	Requested_Market_Survey.Target_Group_Description.Text Business Requirement
	07/07/2009 MSS MSS0004 0..1 Target Group Description
0 .. 1	Requested_Market_Survey.Time_Series.Indicator Business Requirement
	07/07/2009 MSS MSS0011 0..1 Time series
0 .. unbounded	Requested_Market_Survey.Target_CI_Trade_Country Main::CI_Trade_Country.Details Business Requirement
	07/07/2009 MSS MSS0022 0..1 Target Country

Occurrence	Element/Attribute
	Query_Response. Details
0 .. unbounded	— <i>Query_Response. Identification. Identifier</i>
0 .. unbounded	— <i>Query_Response. Content. Text</i>
0 .. unbounded	— <i>Query_Response. Type. Code</i>
0 .. 1	— <i>Query_Response. Respondent. CI_Trade_Party</i>
	Main::CI_Trade_Party. Details

Occurrence	Element/Attribute
	Market Survey_ Query. Details
0 .. unbounded	—Market Survey_ Query. Identification. Identifier Business Requirement 07/07/2009 MSS MSS0034 1..1 Question ID
0 .. unbounded	—Market Survey_ Query. Type. Code Business Requirement 07/07/2009 MSS MSS0035 1..1 Question Type
0 .. unbounded	—Market Survey_ Query. Multi-Choice Answer. Text Business Requirement 07/07/2009 MSS MSS0037 0..1 Question Response Alternatives
0 .. unbounded	—Market Survey_ Query. Content. Text Business Requirement 07/07/2009 MSS MSS0036 1..1 Question Text
0 .. 1	Market Survey_ Query. Specified. Subject_ Classification Main::Subject_ Classification. Details Business Requirement 07/07/2009 MSS MSS0043 0.* Subject Classification
0 .. unbounded	Market Survey_ Query. Submitted. Query_ Response Main::Query_ Response. Details Business Requirement 07/07/2009 MSS MSS0038 0..1 Question Response
0 .. unbounded	—Query_ Response. Identification. Identifier Business Requirement 07/07/2009 MSS MSS0039 1..1 Question Response ID
0 .. unbounded	—Query_ Response. Content. Text Business Requirement 07/07/2009 MSS MSS0040 1..1 Question Response Text
0 .. unbounded	—Query_ Response. Type. Code
0 .. 1	Query_ Response. Respondent. CI_ Trade_ Party Main::CI_ Trade_ Party. Details Business Requirement 07/07/2009 MSS MSS0041 0..1 Question Respondent Party
0 .. 1	Market Survey_ Query. Referenced. Questionnaire_ Section Main::Questionnaire_ Section. Details Business Requirement 07/07/2009 MSS MSS0030 0..1 Section

Occurrence	Element/Attribute
------------	-------------------

Subject_ Classification. Details

0 .. 1	<i>Subject_ Classification. System. Identifier</i>
0 .. unbounded	<i>Subject_ Classification. System Name. Text</i>
0 .. 1	<i>Subject_ Classification. Class. Code</i>
	Business Requirement
	07/07/2009 MSS MSS0044 0..1 Subject Classification Value
0 .. unbounded	<i>Subject_ Classification. Class Name. Text</i>

Occurrence	Element/Attribute
	CI_Document Context_Parameter. Details
0 .. 1	CI_Document Context_Parameter. Identification. Identifier
0 .. 1	CI_Document Context_Parameter. Value. Text
0 .. 1	CI_Document Context_Parameter. Specified. CI_Document_Version Main::CI_Document_Version. Details

Occurrence	Element/Attribute
	CI_Document_Version_Details
0 .. 1	CI_Document_Version_Identification_Identifier
0 .. 1	CI_Document_Version_Name_Text
0 .. 1	CI_Document_Version_Issue_Date_Time

Occurrence	Element/Attribute
------------	-------------------

CI_ Geographical Coordinate. Details

0 .. 1	<ul style="list-style-type: none"> — CI_ Geographical Coordinate. Altitude. Measure <ul style="list-style-type: none"> Business Requirement 13/07/2008 CSC GEO0001 0..1 Geographical Coordinate Altitude
0 .. 1	<ul style="list-style-type: none"> — CI_ Geographical Coordinate. Latitude. Measure <ul style="list-style-type: none"> Business Requirement 13/07/2008 CSC GEO0002 0..1 Geographical Coordinate Latitude Measure
0 .. 1	<ul style="list-style-type: none"> — CI_ Geographical Coordinate. Longitude. Measure <ul style="list-style-type: none"> Business Requirement 13/07/2008 CSC GEO0003 0..1 Geographical Coordinate Longitude Measure - Circular degree qDT
0 .. 1	<ul style="list-style-type: none"> — CI_ Geographical Coordinate. System. Identifier <ul style="list-style-type: none"> Business Requirement 13/07/2008 CSC GEO0006 0..1 Geographical Coordinate System Identifier

Occurrence	Element/Attribute
CI_Legal_Organization. Details	
0 .. 1	<ul style="list-style-type: none"> CI_Legal_Organization. Legal Classification. Code <ul style="list-style-type: none"> Business Requirement 13/07/2008 CSC PAR0013 0..1 Party Legal Classification Code
0 .. 1	<ul style="list-style-type: none"> CI_Legal_Organization. Name. Text <ul style="list-style-type: none"> Business Requirement 13/07/2008 CSC PAR0012 0..1 Party Legal Entity Registration
0 .. 1	<ul style="list-style-type: none"> CI_Legal_Organization. Identification. Identifier <ul style="list-style-type: none"> Business Requirement 13/07/2008 CSC PAR0011 0..1 Party Legal Entity Identification
0 .. 1	<ul style="list-style-type: none"> CI_Legal_Organization. Postal. CI_Trade_Address <ul style="list-style-type: none"> Main::CI_Trade_Address. Details Business Requirement 13/07/2008 CSC PAR0015 0..1 Party Legal Entity Registration Address - <ul style="list-style-type: none"> maybe a specific ASCC with PT Registration should be added as
0 .. unbounded	<ul style="list-style-type: none"> CI_Legal_Organization. Authorized. CI_Legal_Registration <ul style="list-style-type: none"> Main::CI_Legal_Registration. Details

Occurrence	Element/Attribute
	CI_Legal_Registration. Details
0 .. 1	<ul style="list-style-type: none"> — <i>CI_Legal_Registration. Type. Code</i> Business Requirement 13/07/2008 CSC PAR0014 0..1 Party Legal Corporate Registration Scheme: cardinality changed to 0..* 20MAR09
0 .. 1	<ul style="list-style-type: none"> — <i>CI_Legal_Registration. Identification. Identifier</i> Business Requirement 13/07/2008 CSC PAR0003 0..* Party Tax Identifier

Occurrence	Element/Attribute				
	CI_ Note. Details				
0 .. 1	<i>CI_ Note. Subject. Text</i> Business Requirement				
	13/07/2008 CSC	NOT0003	0..1	Note Subject Text :	
0 .. 1	<i>CI_ Note. Content. Code</i> Business Requirement				
	13/07/2008 CSC	NOT0004	0..1	Note Content Code	
0 .. unbounded	<i>CI_ Note. Content. Text</i> Business Requirement				
	13/07/2008 CSC changed to	NOT0005	0..1	Note Content Text : cardinality	
0 .. 1	<i>CI_ Note. Subject. Code</i> Business Requirement				
	13/07/2008 CSC	NOT0002	0..1	Note Subject Code	
0 .. 1	<i>CI_ Note. Identification. Identifier</i> Business Requirement				
	13/07/2008 CSC	NOT0001	0..1	Note Identifier	

Occurrence	Element/Attribute
CI_ Referenced_ Document. Details	
0 .. 1	CI_ Referenced_ Document. Issuer Assigned_ Identification. Identifier Business Requirement 12/07/2008 CSC REF0001 1..1 Reference number
0 .. 1	CI_ Referenced_ Document. URI_ Identification. Identifier Business Requirement 12/07/2008 CSC REF0006 0..1 Reference URI
0 .. 1	CI_ Referenced_ Document. Issue. Date Time Business Requirement 12/07/2008 CSC REF0003 0..1 Reference date
0 .. 1	CI_ Referenced_ Document. Status. Code Business Requirement 12/07/2008 CSC REF0004 0..1 Reference status
0 .. 1	CI_ Referenced_ Document. Copy. Indicator Business Requirement 12/07/2008 CSC REF0008 0..1 Copy indicator
0 .. 1	CI_ Referenced_ Document. Line. Identifier Business Requirement 12/07/2008 CSC REF0009 0..1 Reference line number
0 .. 1	CI_ Referenced_ Document. Reference_ Type. Code Business Requirement 08/09/2008 CSC REF0012 0..1 Document type
0 .. 1	CI_ Referenced_ Document. Global_ Identification. Identifier Business Requirement 08/09/2008 CSC REF0007 0..1 Reference GUID
0 .. 1	CI_ Referenced_ Document. Revision_ Identification. Identifier Business Requirement 08/09/2008 CSC REF0005 0..1 Reference index ID
0 .. unbounded	CI_ Referenced_ Document. Name. Text Business Requirement 12/07/2008 CSC REF0002 0..1 Reference Document Name
0 .. unbounded	CI_ Referenced_ Document. Information. Text
0 .. unbounded	CI_ Referenced_ Document. Previous Revision_ Identification. Identifier
0 .. unbounded	CI_ Referenced_ Document. Section Name. Text
0 .. 1	CI_ Referenced_ Document. Issuer. CI_ Trade_ Party Main::CI_ Trade_ Party. Details Business Requirement 12/07/2008 CSC REF0011 0..1 Referenced document issuer party
0 .. unbounded	CI_ Referenced_ Document. Attached. Specified_ Binary File Main::Specified_ Binary File. Details Business Requirement 15/05/2009 CSC REF0014 0..* Attached Binary File
0 .. 1	CI_ Referenced_ Document. Effective. CI_ Specified_ Period Main::CI_ Specified_ Period. Details

Occurrence	Element/Attribute
------------	-------------------

CI_Registered_Tax_Details

0 .. 1	CI_Registered_Tax_Type.Code
0 .. 1	CI_Registered_Tax_ExemptionReason.Code
0 .. unbounded	CI_Registered_Tax_ExemptionReason.Text
0 .. 1	CI_Registered_Tax_Currency.Code
0 .. unbounded	CI_Registered_Tax_Jurisdiction.Text
0 .. unbounded	CI_Registered_Tax_Description.Text
0 .. 1	CI_Registered_Tax_CustomsDuty.Indicator

Occurrence	Element/Attribute
------------	-------------------

CI_Specified_Period.Details

0 .. unbounded	CI_Specified_Period.Duration.Measure
0 .. 1	CI_Specified_Period.Inclusive.Indicator
0 .. unbounded	CI_Specified_Period.Description.Text
0 .. 1	CI_Specified_Period.Start.Date Time
0 .. 1	CI_Specified_Period.End.Date Time
0 .. 1	CI_Specified_Period.Complete.Date Time
0 .. 1	CI_Specified_Period.Season.Code
0 .. 1	CI_Specified_Period.Identification.Identifier
0 .. unbounded	CI_Specified_Period.Name.Text
0 .. 1	CI_Specified_Period.Sequence.Numeric
0 .. 1	CI_Specified_Period.Start Date Flexibility.Code
0 .. 1	CI_Specified_Period.Continuous.Indicator

Occurrence	Element/Attribute
	CI_Tax_Registration. Details
0 .. 1	CI_Tax_Registration. Identification. Identifier
0 .. 1	CI_Tax_Registration. Associated. CI_Registered_Tax
	Main::CI_Registered_Tax. Details

Occurrence	Element/Attribute
	CI_Trade_Address_Details
0 .. 1	<ul style="list-style-type: none"> — <i>CI_Trade_Address_Identification_Identifier</i> Business Requirement 12/07/2008 CSC ADR0001 0..1 Address Identification
0 .. 1	<ul style="list-style-type: none"> — <i>CI_Trade_Address_Postcode_Code</i> Business Requirement 12/07/2008 CSC ADR0007 0..1 Postcode
0 .. 1	<ul style="list-style-type: none"> — <i>CI_Trade_Address_PostOfficeBox_Text</i> Business Requirement 12/07/2008 CSC ADR0002 0..1 Post Office Box
0 .. 1	<ul style="list-style-type: none"> — <i>CI_Trade_Address_BuildingName_Text</i> Business Requirement 12/07/2008 CSC ADR0004 0..1 Building name
0 .. 1	<ul style="list-style-type: none"> — <i>CI_Trade_Address_LineOne_Text</i> Business Requirement 12/07/2008 CSC ADR0008 0..1 Address line one
0 .. 1	<ul style="list-style-type: none"> — <i>CI_Trade_Address_LineTwo_Text</i> Business Requirement 12/07/2008 CSC ADR0009 0..1 Address line two
0 .. 1	<ul style="list-style-type: none"> — <i>CI_Trade_Address_LineThree_Text</i> Business Requirement 12/07/2008 CSC ADR0010 0..1 Address line three
0 .. 1	<ul style="list-style-type: none"> — <i>CI_Trade_Address_LineFour_Text</i> Business Requirement 12/07/2008 CSC ADR0011 0..1 Address line four
0 .. 1	<ul style="list-style-type: none"> — <i>CI_Trade_Address_LineFive_Text</i> Business Requirement 12/07/2008 CSC ADR0012 0..1 Address line five
0 .. 1	<ul style="list-style-type: none"> — <i>CI_Trade_Address_StreetName_Text</i> Business Requirement 12/07/2008 CSC ADR0003 0..1 Street name
0 .. 1	<ul style="list-style-type: none"> — <i>CI_Trade_Address_CityName_Text</i> Business Requirement 12/07/2008 CSC ADR0005 0..1 City name
0 .. 1	<ul style="list-style-type: none"> — <i>CI_Trade_Address_CitySubDivisionName_Text</i> Business Requirement 12/07/2008 CSC ADR0006 0..1 City Sub Division name
0 .. 1	<ul style="list-style-type: none"> — <i>CI_Trade_Address_Country_Identifier</i> Business Requirement 12/07/2008 CSC ADR0013 0..1 Country Identification
0 .. unbounded	<ul style="list-style-type: none"> — <i>CI_Trade_Address_CountryName_Text</i> Business Requirement 12/07/2008 CSC ADR0014 0..1 Country name
0 .. 1	<ul style="list-style-type: none"> — <i>CI_Trade_Address_CountrySubDivision_Identifier</i> Business Requirement 12/07/2008 CSC ADR0015 0..1 Country Sub-Division identification
0 .. unbounded	<ul style="list-style-type: none"> — <i>CI_Trade_Address_CountrySubDivisionName_Text</i> Business Requirement 12/07/2008 CSC ADR0016 0..1 Country Sub-Division name
0 .. 1	<ul style="list-style-type: none"> — <i>CI_Trade_Address_AttentionOf_Text</i> Business Requirement 13/07/2008 CSC PAR0006 0..1 Party Attention Of Indicator
0 .. 1	<ul style="list-style-type: none"> — <i>CI_Trade_Address_CareOf_Text</i> Business Requirement 13/07/2008 CSC PAR0005 0..1 Party Mark Care Of Indicator
0 .. 1	<ul style="list-style-type: none"> — <i>CI_Trade_Address_BuildingNumber_Text</i> Business Requirement 12/07/2008 CSC ADR0017 0..1 Building Number

Occurrence	Element/Attribute
	CI_Trade_Contact_Details
0 .. 1	CI_Trade_Contact. Identification. Identifier Business Requirement 12/07/2008 CSC CON0001 0..1 Contact identification
0 .. 1	CI_Trade_Contact. Person Name. Text Business Requirement 12/07/2008 CSC CON0006 0..1 Contact person name
0 .. 1	CI_Trade_Contact. Department Name. Text Business Requirement 12/07/2008 CSC CON0004 0..1 Contact department name
0 .. 1	CI_Trade_Contact. Type. Code Business Requirement 12/07/2008 CSC CON0007 0..1 Contact type code
0 .. 1	CI_Trade_Contact. Job Title. Text Business Requirement 12/07/2008 CSC CON0002 0..1 Contact job title
0 .. 1	CI_Trade_Contact. Responsibility. Text Business Requirement 12/07/2008 CSC CON0003 0..1 Contact responsibility
0 .. unbounded	CI_Trade_Contact. Person_ Identification. Identifier Business Requirement 12/07/2008 CSC CON0005 0..1 Contact person identifier
0 .. 1	CI_Trade_Contact. Telephone. CI_ Universal_ Communication Main::CI_ Universal_ Communication. Details Business Requirement 12/07/2008 CSC COM0001 0..1 Identification Identifier mapping
0 .. 1	CI_Trade_Contact. Direct_ Telephone. CI_ Universal_ Communication Main::CI_ Universal_ Communication. Details Business Requirement 12/07/2008 CSC CON0010 0..1 Direct telephone number
0 .. 1	CI_Trade_Contact. Mobile_ Telephone. CI_ Universal_ Communication Main::CI_ Universal_ Communication. Details Business Requirement 12/07/2008 CSC CON0011 0..1 Mobile telephone number
0 .. 1	CI_Trade_Contact. Fax. CI_ Universal_ Communication Main::CI_ Universal_ Communication. Details Business Requirement 12/07/2008 CSC CON0012 0..1 Fax number
0 .. 1	CI_Trade_Contact. Email_ URI. CI_ Universal_ Communication Main::CI_ Universal_ Communication. Details Business Requirement 12/07/2008 CSC CON0014 0..1 E-mail address
0 .. 1	CI_Trade_Contact. Telex. CI_ Universal_ Communication Main::CI_ Universal_ Communication. Details Business Requirement 12/07/2008 CSC CON0013 0..1 Telex number
0 .. 1	CI_Trade_Contact. VOIP. CI_ Universal_ Communication Main::CI_ Universal_ Communication. Details Business Requirement 12/07/2008 CSC CON0015 0..1 Other communication (VOIP)
0 .. 1	CI_Trade_Contact. Instant Messaging. CI_ Universal_ Communication Main::CI_ Universal_ Communication. Details Business Requirement 12/07/2008 CSC CON0015 0..1 Other communication (Instant
0 .. unbounded	CI_Trade_Contact. Specified. CI_ Note Main::CI_ Note. Details Business Requirement 12/07/2008 CSC CON0008 0..* Note

Occurrence

Element/Attribute

CI_Trade_Country Sub-Division. Details

0 .. 1

└ CI_Trade_Country Sub-Division. Identification. Identifier

0 .. unbounded

└ CI_Trade_Country Sub-Division. Name. Text

Occurrence	Element/Attribute
CI_Trade_Country_Details	
0 .. 1	CI_Trade_Country.Identification.Identifier
0 .. unbounded	CI_Trade_Country.Name.Text
0 .. unbounded	CI_Trade_Country.Subordinate.CI_Trade_Country Sub-Division
	Main::CI_Trade_Country Sub-Division.Details

Occurrence	Element/Attribute
	CI_Trade_Party_Details
0 .. unbounded	CI_Trade_Party_Identification_Identifier Business Requirement
	13/07/2008 CSC PAR0001 1..1 Party Identification
0 .. unbounded	CI_Trade_Party_Global_Identifier_Identifier Business Requirement
	13/07/2008 CSC PAR0002 0.* Party additional identification
0 .. 1	CI_Trade_Party_Name_Text Business Requirement
	13/07/2008 CSC PAR0004 0..1 Party Name
0 .. unbounded	CI_Trade_Party_Role_Code
0 .. 1	CI_Trade_Party_Specified_CI_Legal_Organization Main::CI_Legal_Organization_Details
	Business Requirement
	13/07/2008 CSC PAR0010 0..1 Party Legal Entity
0 .. unbounded	CI_Trade_Party_Defined_CI_Trade_Contact Main::CI_Trade_Contact_Details
	Business Requirement
	13/07/2008 CSC PAR0016 0..1 Party Contract Contact
	13/07/2008 CSC PAR0017 0..1 Party Technical Contact
	13/07/2008 CSC PAR0018 0..1 Party New Development Contact
	13/07/2008 CSC PAR0019 0..1 Party Order Processing Contact
	13/07/2008 CSC PAR0020 0..1 Party Customer Relations Contact
	13/07/2008 CSC PAR0021 0..1 Party Delivery Contact
	13/07/2008 CSC PAR0022 0..1 Party Goods Receiving Contact
	13/07/2008 CSC PAR0023 0..1 Party Material Control Contact
	13/07/2008 CSC PAR0024 0..1 Party Information Contact
	13/07/2008 CSC PAR0025 0..1 Party Order Contact
	13/07/2008 CSC PAR0026 0..1 Party Sales Administration Contact
	13/07/2008 CSC PAR0027 0..1 Party Supplier Contact
	13/07/2008 CSC PAR0028 0..1 Party Technical Documentation
	13/07/2008 CSC PAR0029 0..1 Party Accounting Contact
0 .. 1	CI_Trade_Party_Postal_CI_Trade_Address Main::CI_Trade_Address_Details
	Business Requirement
	13/07/2008 CSC PAR0030 0..1 Party Postal Address
0 .. unbounded	CI_Trade_Party_URI_CI_Universal_Communication Main::CI_Universal_Communication_Details
	Business Requirement
	13/07/2008 CSC PAR0008 0..1 Party web-site_Uniform Resource Identification
0 .. unbounded	CI_Trade_Party_Specified_CI_Tax_Registration Main::CI_Tax_Registration_Details
	Business Requirement
	08/11/2008 CSC PAR0003 0.* Party tax Identification
0 .. 1	CI_Trade_Party_End_Point_URI_CI_Universal_Communication Main::CI_Universal_Communication_Details
	Business Requirement
	13/07/2008 CSC PAR0007 0..1 Party End Point Identifier
0 .. unbounded	CI_Trade_Party_Logo_Associated_Specified_Binary_File Main::Specified_Binary_File_Details

Occurrence	Element/Attribute
	CI_ Universal_ Communication. Details
0 .. 1	<ul style="list-style-type: none"> — <i>CI_ Universal_ Communication. URI. Identifier</i> <ul style="list-style-type: none"> Business Requirement 12/07/2008 CSC COM0002 0..1 URI identifier — <i>CI_ Universal_ Communication. Channel. Code</i> <ul style="list-style-type: none"> Business Requirement 12/07/2008 CSC COM0004 0..1 Channel Code — <i>CI_ Universal_ Communication. Complete Number. Text</i> <ul style="list-style-type: none"> Business Requirement 12/07/2008 CSC COM0005 0..1 Complete Number

Occurrence	Element/Attribute
------------	-------------------

Specified_ Binary File. Details

0 .. unbounded	Specified_ Binary File. Identification. Identifier
0 .. unbounded	Specified_ Binary File. Title. Text
0 .. unbounded	Specified_ Binary File. Author Name. Text
0 .. unbounded	Specified_ Binary File. Version. Identifier
0 .. unbounded	Specified_ Binary File. File Name. Text
0 .. unbounded	Specified_ Binary File. URI. Identifier
0 .. unbounded	Specified_ Binary File. MIME. Code
0 .. unbounded	Specified_ Binary File. Encoding. Code
0 .. unbounded	Specified_ Binary File. Character Set. Code
0 .. unbounded	Specified_ Binary File. Included. Binary Object
0 .. unbounded	Specified_ Binary File. Access. Text
0 .. unbounded	Specified_ Binary File. Description. Text
0 .. unbounded	Specified_ Binary File. Size. Measure
0 .. unbounded	Specified_ Binary File. Access Availability. Specified_ Period
	Main::Specified_ Period. Details

8. Core components UN/CEFACT Registry version used

The Market Survey Information model described in this document and submitted by the Trade and Business Process Group for Supply Chain, TBG1, has been harmonized with models and submissions of other Trade and Business Process Groups. It re-uses core components extensively. Therefore this document is based on the draft UN/CEFACT Core Component Library CCL09B dated Oct 2009.

9. Draft Core Component reference

All the new (draft) Core Components, Business Information Entities, and Qualified Data Types that have been used in this RSM have been submitted for registration in the UN/CEFACT Registry version 09B.

10. Additional documentation

This section identifies any additional documentation that will be registered with the canonical model in respect to the BCCs or ACCs that have been provided for registration in the UN/CEFACT Registry.

Not applicable at this point in time.

11. Additional information



CCL09B MSI MA.xls

Message assembly Excel sheet: